

United MUFFLER CORP.

TRUCK EXHAUST SYSTEMS



United MUFFLER CORP.

Manufacturing Truck-Bus Exhaust Systems Since 1959

We appreciate your business!

1-866-229-3402

UNITED MUFFLER CORP.

TRUCK

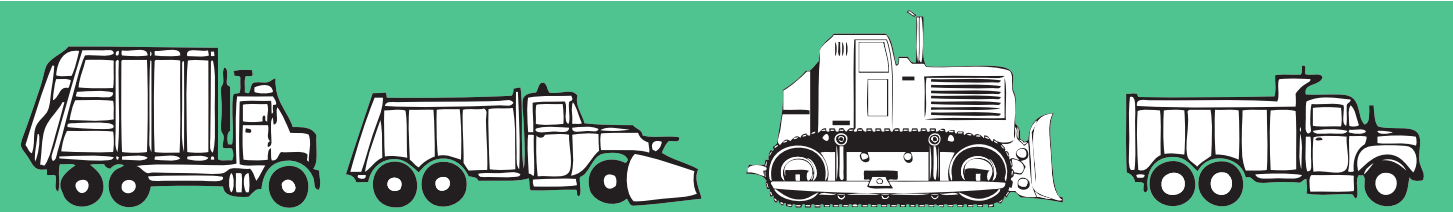

TRUCK EXHAUST SYSTEMS

C A T A L O G

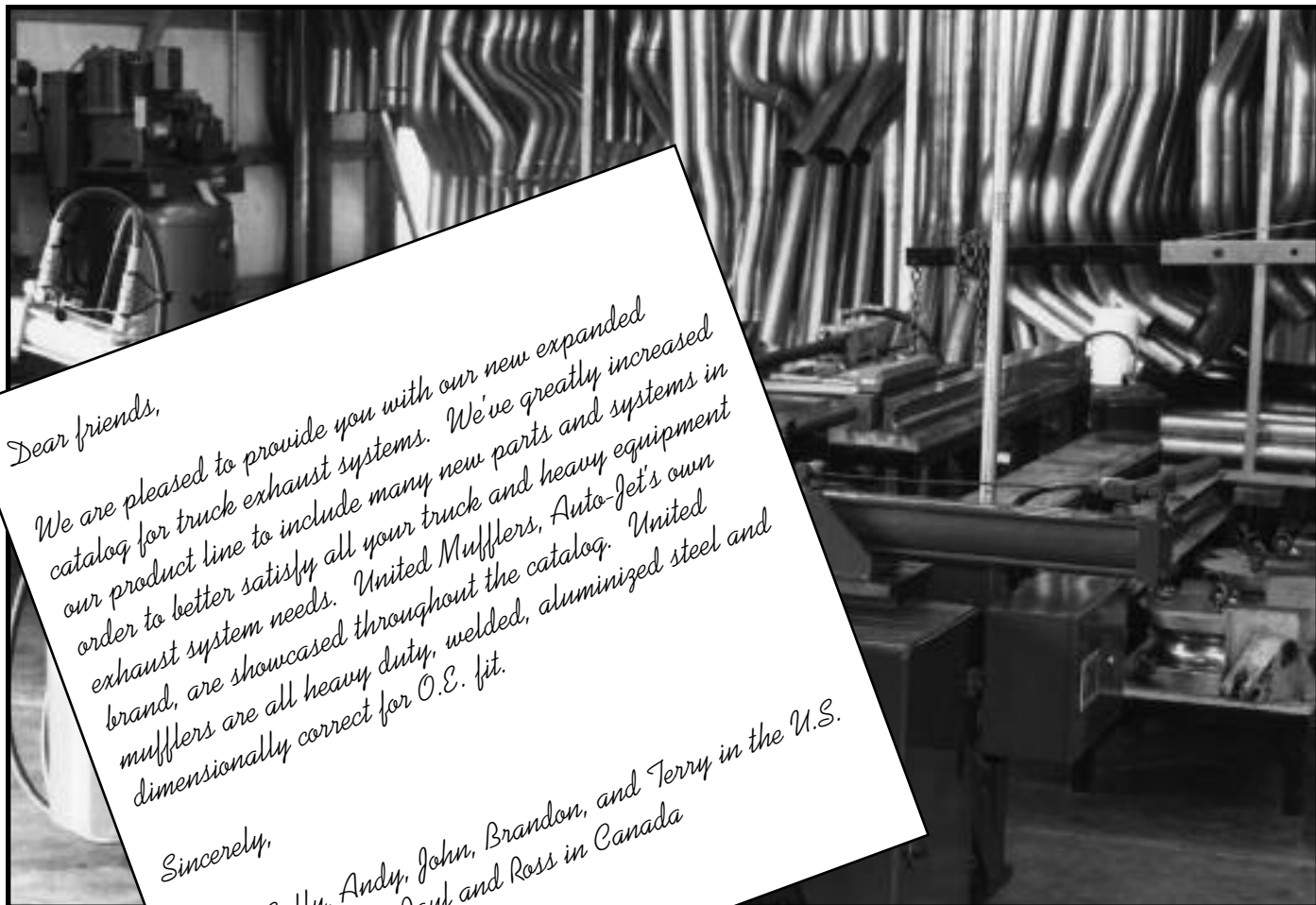

Dear friends,

We are pleased to provide you with our new expanded catalog for truck exhaust systems. We've greatly increased our product line to include many new parts and systems in order to better satisfy all your truck and heavy equipment exhaust system needs. United Mufflers, Auto-Jet's own brand, are showcased throughout the catalog. United mufflers are all heavy duty, welded, aluminized steel and dimensionally correct for O.E. fit.

Sincerely,

Steve, Sally, Andy, John, Brandon, and Terry in the U.S.
 Tony, Carol, Joe, Paul and Ross in Canada
 Sales Staff

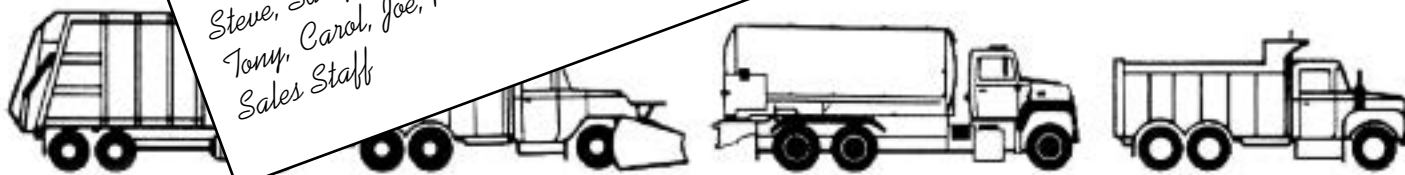

SECTION	TABLE OF CONTENTS	PAGES
MUFFLERS		MUFF 1 - MUFF 24
ACCESSORIES		ACC 1 - ACC 16
LIGHT DUTY		LD 1 - LD 8
STERLING-FORD EXHAUST SYSTEMS.....		FORD 1 - FORD 20
CHEVROLET/GMC EXHAUST SYSTEMS.....		GM 1 - GM 16
NAVISTAR EXHAUST SYSTEMS		NAV 1 - NAV 12
OFF-ROAD EQUIPMENT MUFFLERS - CATERPILLAR AND MORE		OR 1 - OR 18

UNITED MUFFLER CORP.

U.S. toll free 1-800-247-5391 • Fax 515-224-0727 • website: www.auto-jet.com
 Canada toll free 1-866-229-3402 • Fax 519-455-1103 • website: www.unitedmuffler.com

MUFFLERS



Nationwide toll free 1-866-229-3402

Fax 519-455-1103 • website: www.unitedmuffler.com

RUGGED!

HEAVY DUTY
ALL WELDED
ALUMINIZED

MUFFLERS



6" DIAMETER

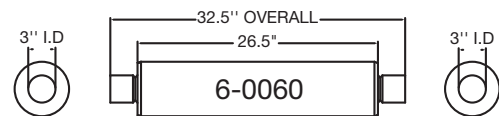
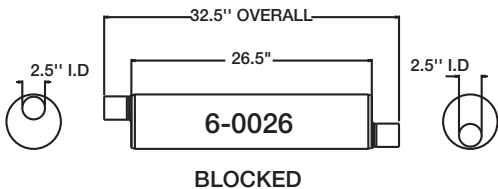
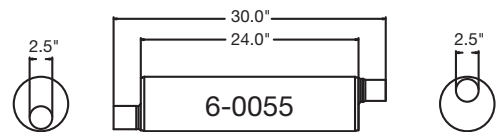
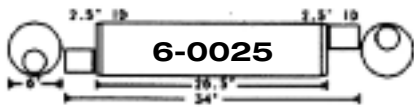
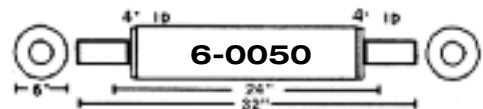
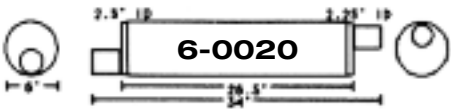
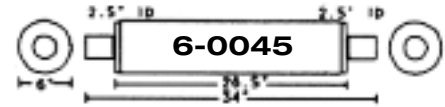
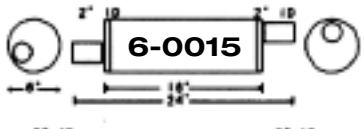
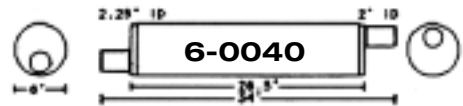
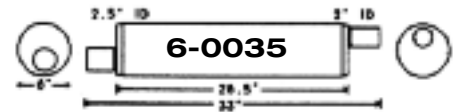
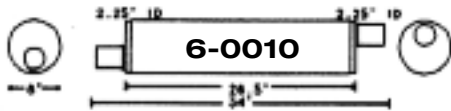
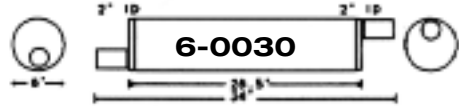
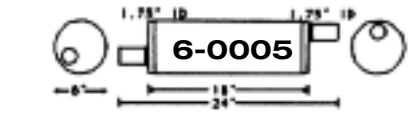

UNITED MUFFLER CORP.

U.S. toll free 1-800-247-5391 • Fax 515-224-0727 • website: www.auto-jet.com
Canada toll free 1-866-229-3402 • Fax 519-455-1103 • website: www.unitedmuffler.com

MUFF 1



MUFFLERS



7" DIAMETER

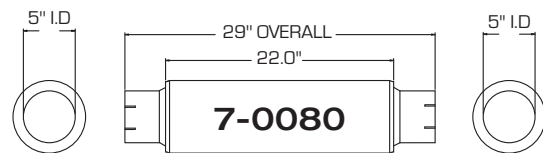
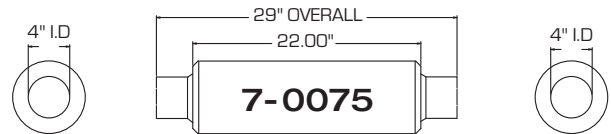
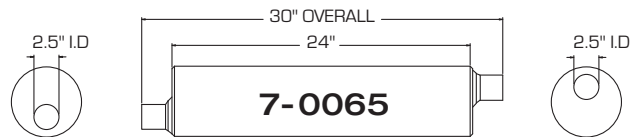
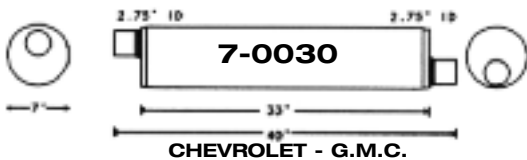
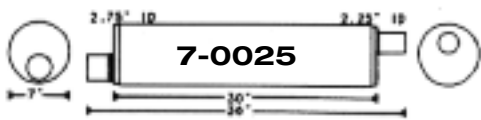
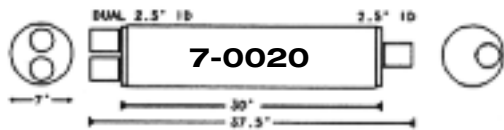
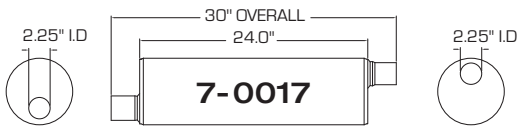
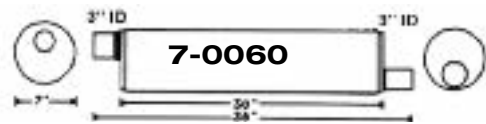
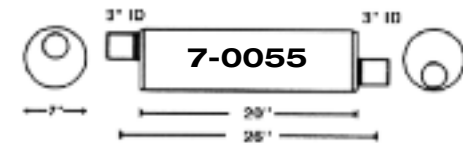
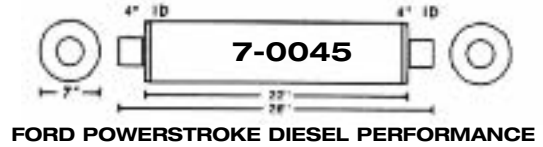
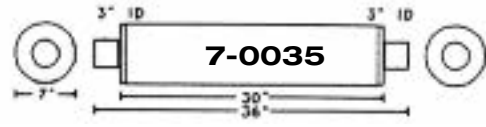
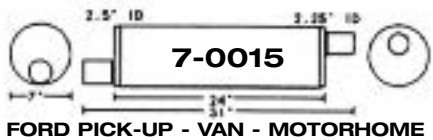
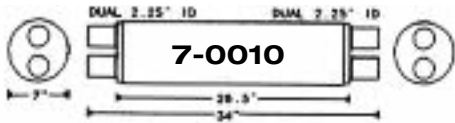
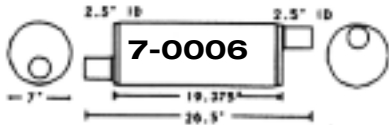
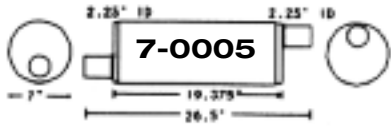

UNITED MUFFLER CORP.

U.S. toll free 1-800-247-5391 • Fax 515-224-0727 • website: www.auto-jet.com
 Canada toll free 1-866-229-3402 • Fax 519-455-1103 • website: www.unitedmuffler.com

MUFF 2

RUGGED!

HEAVY DUTY
ALL WELDED
ALUMINIZED

MUFFLERS



8-1/2" DIAMETER

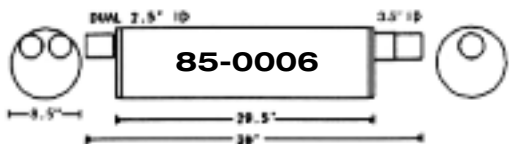
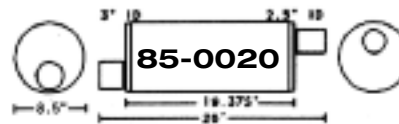
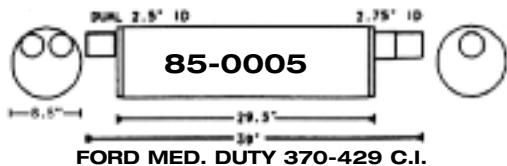

FORD MED. DUTY 370-429 C.I. "HIGH FLOW"

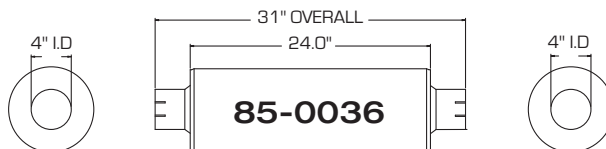
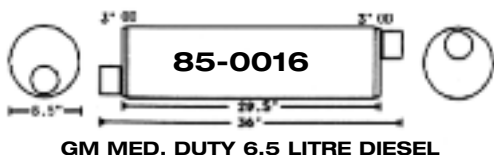
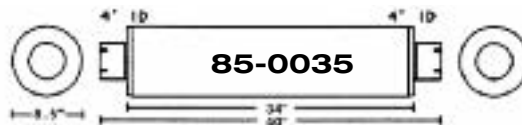
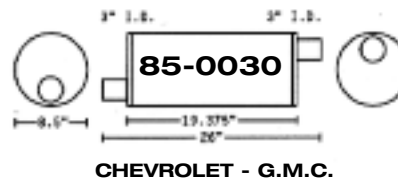
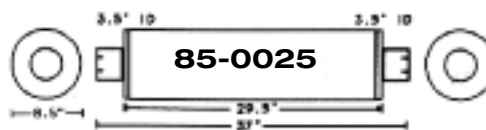

NOTE: See page 18 for custom mufflers

UNITED MUFFLER CORP.

U.S. toll free 1-800-247-5391 • Fax 515-224-0727 • website: www.auto-jet.com
Canada toll free 1-866-229-3402 • Fax 519-455-1103 • website: www.unitedmuffler.com

MUFF 3



MUFFLERS



8-1/2" DIAMETER

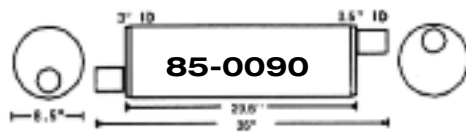
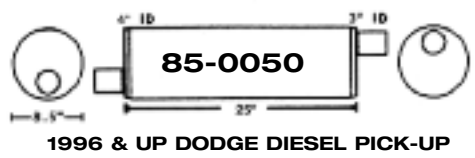
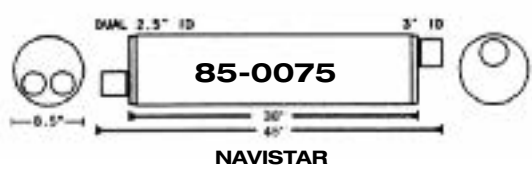
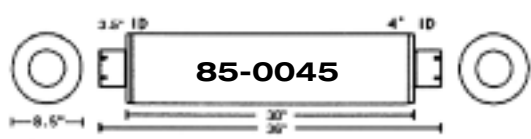
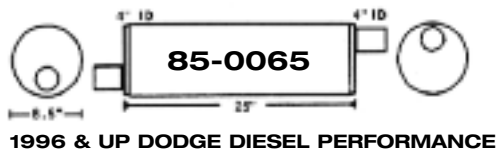
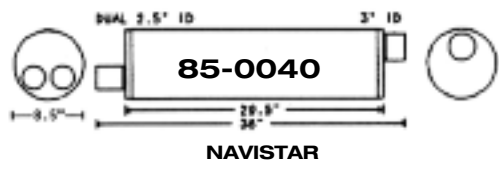
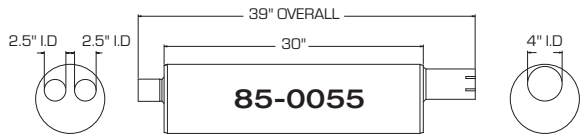
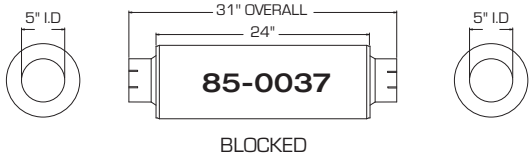

NOTE: See page 18 for custom mufflers

UNITED MUFFLER CORP.

U.S. toll free 1-800-247-5391 • Fax 515-224-0727 • website: www.auto-jet.com
 Canada toll free 1-866-229-3402 • Fax 519-455-1103 • website: www.unitedmuffler.com

RUGGED!

HEAVY DUTY
ALL WELDED
ALUMINIZED

MUFFLERS



10" DIAMETER

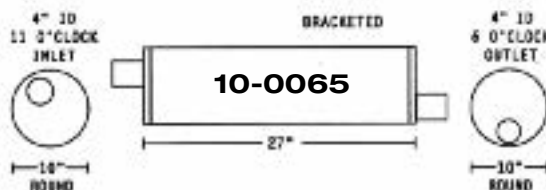
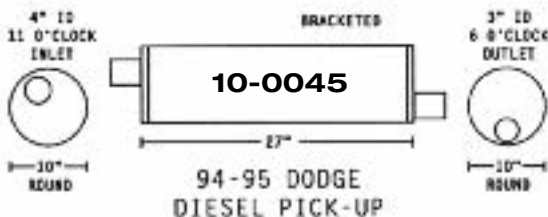
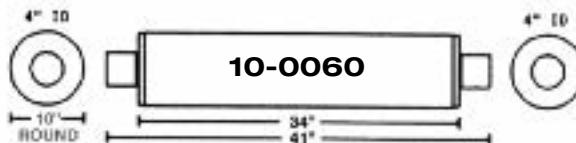
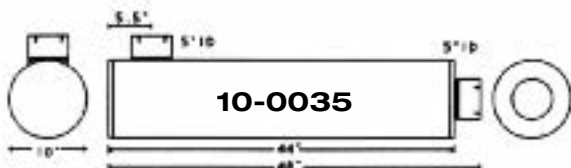
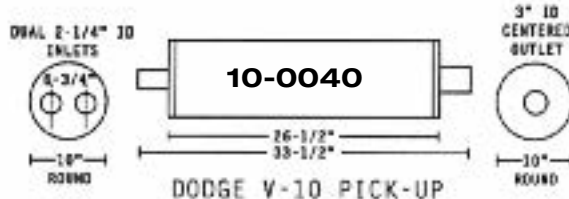
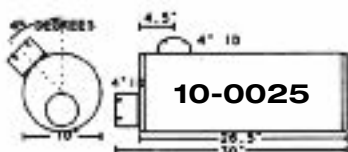
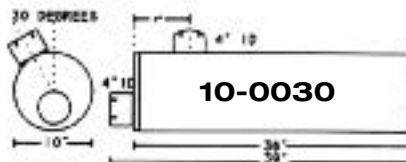
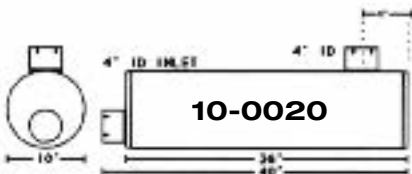
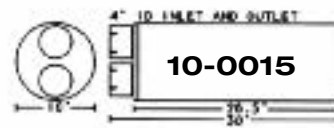
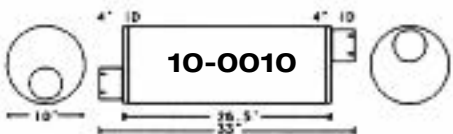
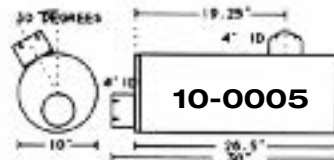
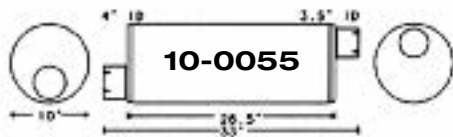

NOTE: See page 18 for custom mufflers

UNITED MUFFLER CORP.

U.S. toll free 1-800-247-5391 • Fax 515-224-0727 • website: www.auto-jet.com
Canada toll free 1-866-229-3402 • Fax 519-455-1103 • website: www.unitedmuffler.com



MUFFLERS



11" DIAMETER

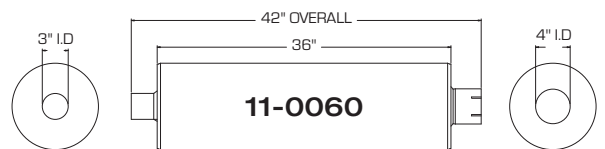
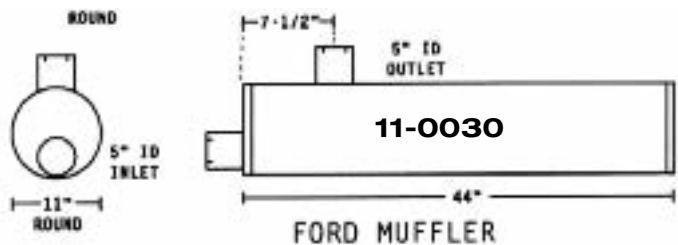
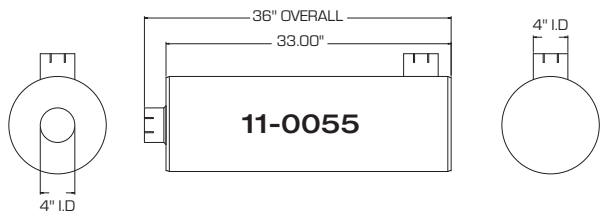
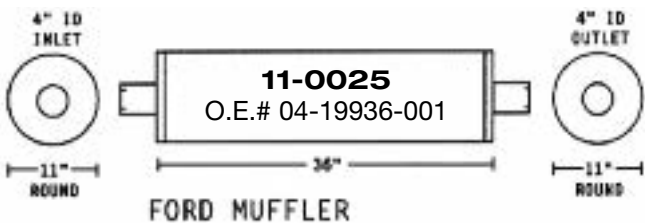
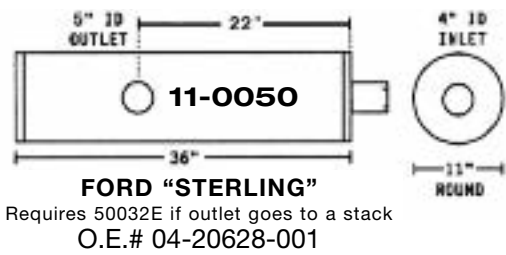
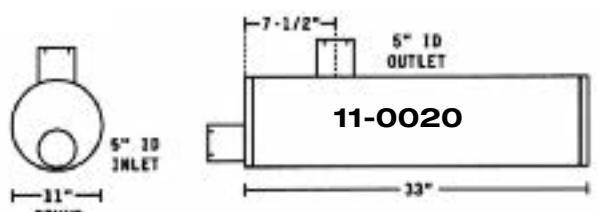
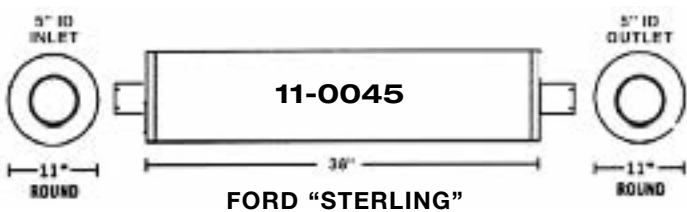
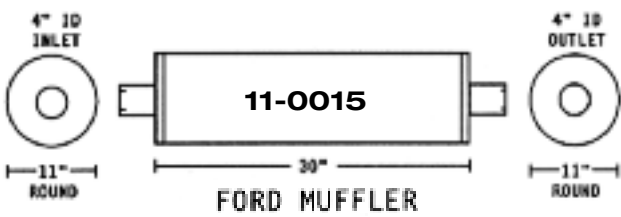
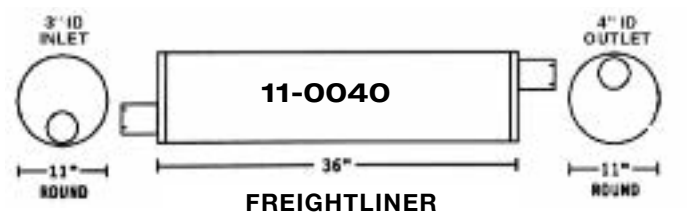
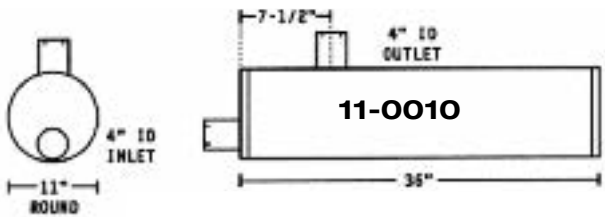
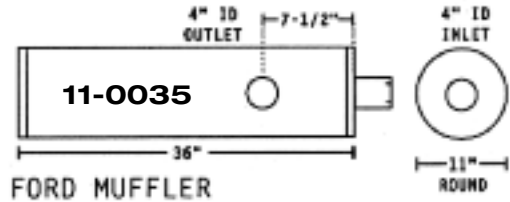
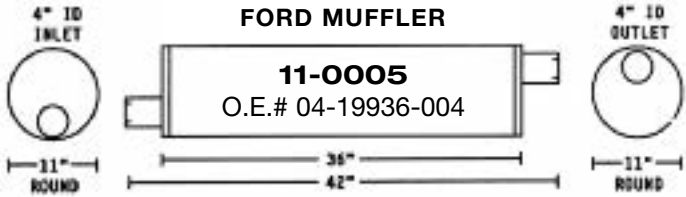

NOTE: See page 18 for custom mufflers

UNITED MUFFLER CORP.

U.S. toll free 1-800-247-5391 • Fax 515-224-0727 • website: www.auto-jet.com
 Canada toll free 1-866-229-3402 • Fax 519-455-1103 • website: www.unitedmuffler.com

RUGGED!

HEAVY DUTY
ALL WELDED
ALUMINIZED

MUFFLERS



11" DIAMETER

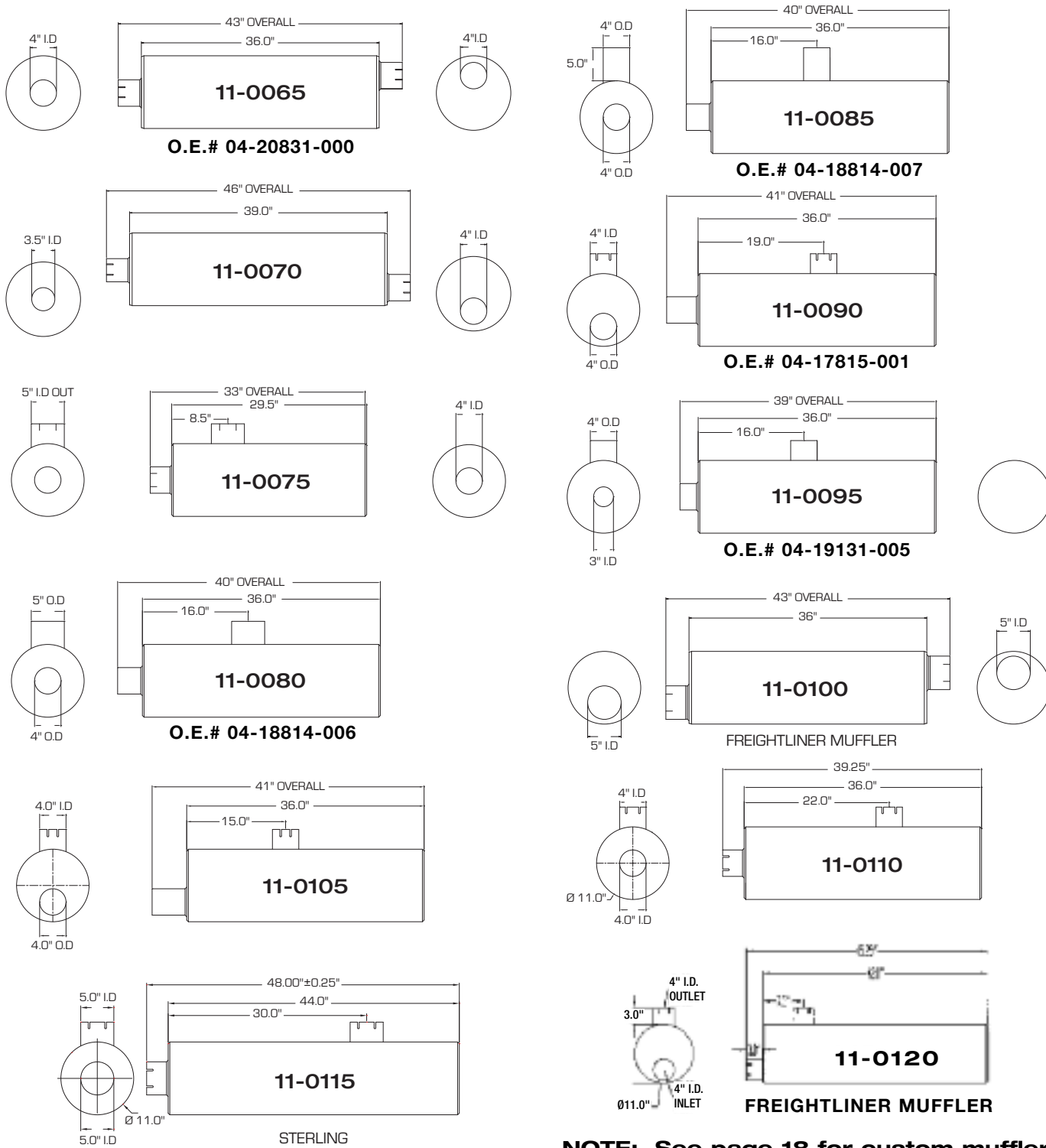

NOTE: See page 18 for custom mufflers

UNITED MUFFLER CORP.

U.S. toll free 1-800-247-5391 • Fax 515-224-0727 • website: www.auto-jet.com
Canada toll free 1-866-229-3402 • Fax 519-455-1103 • website: www.unitedmuffler.com



MUFFLERS

RUGGED!
HEAVY DUTY
ALL WELDED
ALUMINIZED

4-1/4" X 11" OVALS

PICK-UP & VAN

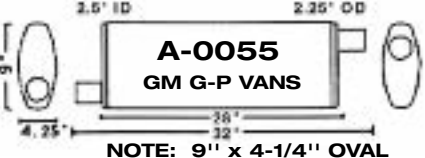
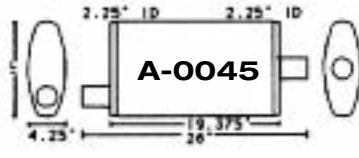
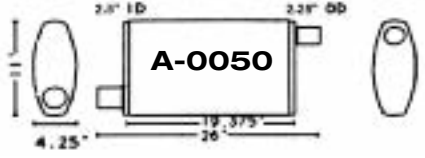
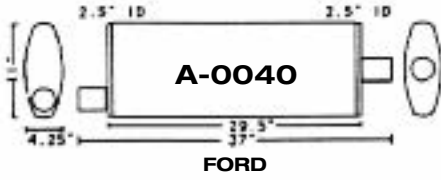
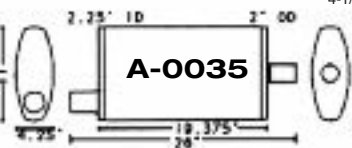
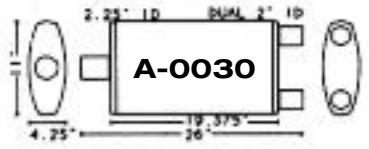
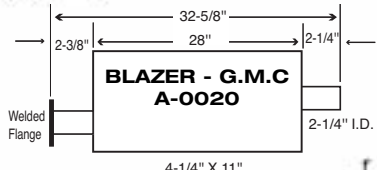
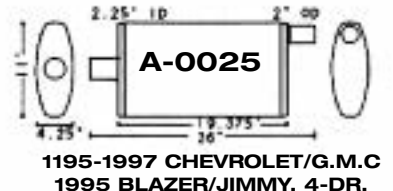
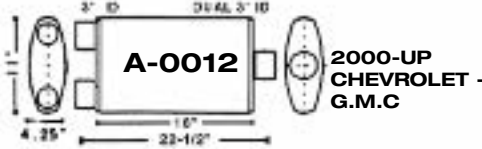
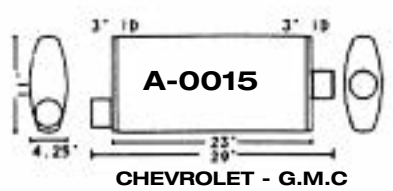
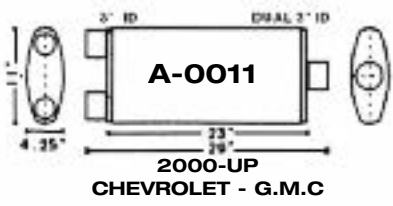
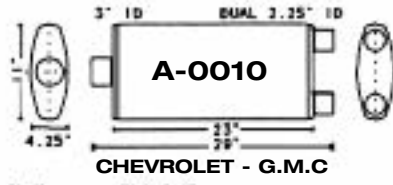
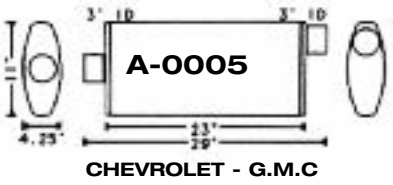

NOTE: 9" x 4-1/4" OVAL

UNITED MUFFLER CORP.

U.S. toll free 1-800-247-5391 • Fax 515-224-0727 • website: www.auto-jet.com
Canada toll free 1-866-229-3402 • Fax 519-455-1103 • website: www.unitedmuffler.com

MUFF 8

RUGGED!

HEAVY DUTY
ALL WELDED
ALUMINIZED

MUFFLERS



4-1/4" X 11" OVALS

PICK-UP & VAN

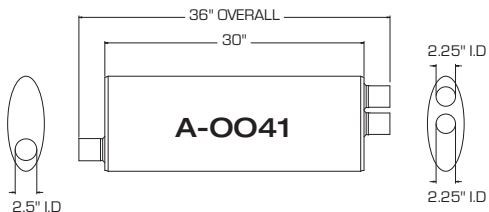
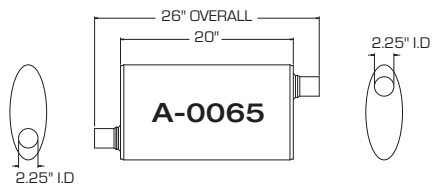
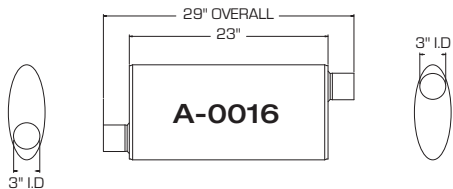
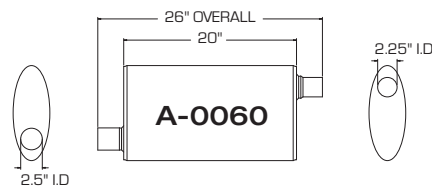
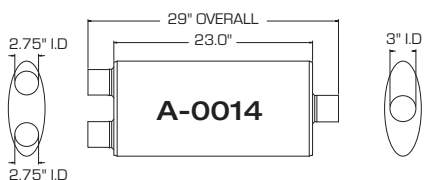
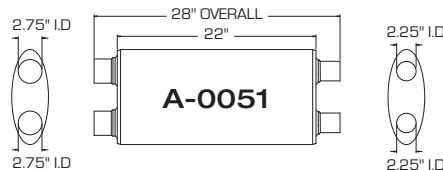
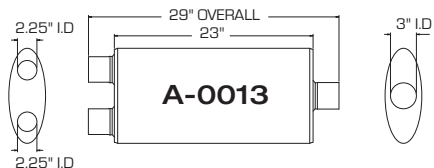

NOTE: See page 18 for custom mufflers

12" DIAMETER

FORD L8000

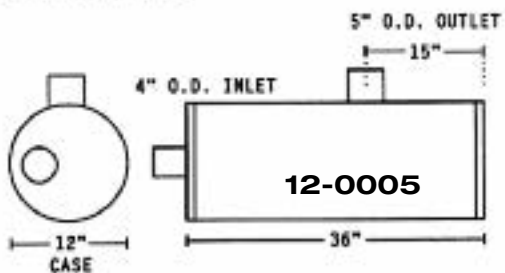

FORD L8000

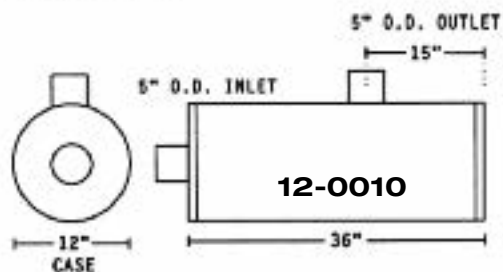

UNITED MUFFLER CORP.

U.S. toll free 1-800-247-5391 • Fax 515-224-0727 • website: www.auto-jet.com
Canada toll free 1-866-229-3402 • Fax 519-455-1103 • website: www.unitedmuffler.com

MUFF 9



MUFFLERS



7" X 9" OVALS

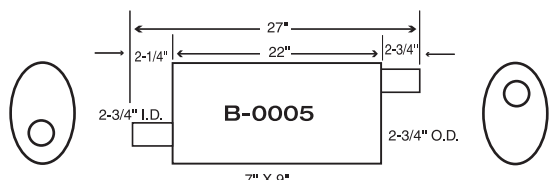

**1994-1995
CHEVROLET/G.M.C.
C1500/2500,
K1500/2500**

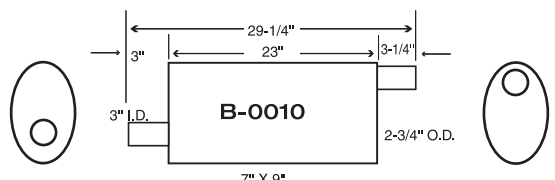

**1992-1995
CHEVROLET/G.M.C.
G SERIES, G30/3500 (92-94)**

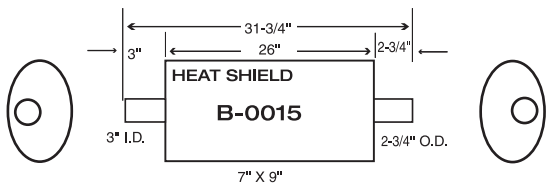

**1994-1995
CHEVROLET/G.M.C.
C1500/2500, K1500/2500,
SUBURBAN, 2WD with
3" INLET**

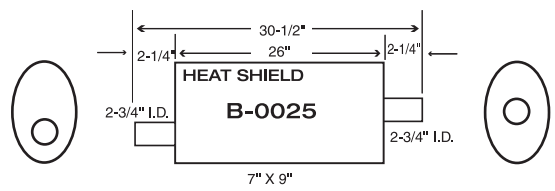

**1994-1995
CHEVROLET/G.M.C.
C1500/2500,
K1500/2500, SUBURBAN**

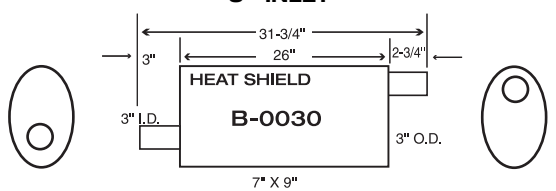

**1992-1993
CHEVROLET/G.M.C.
C1500/2500,
K1500/2500, SUBURBAN**

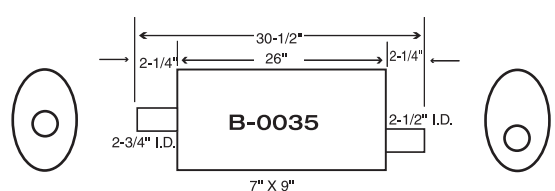

**1992-1994
DODGE/PLYMOUTH
B150/250/350**

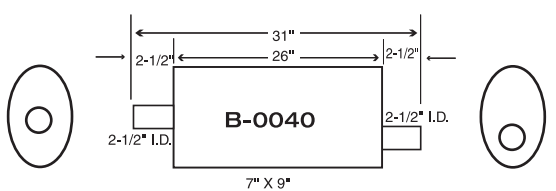

**1994-1997
DODGE/PLYMOUTH
B150/250/350**

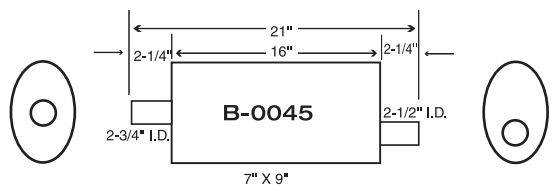

**1992-1996
DODGE RAM, DAKOTA**

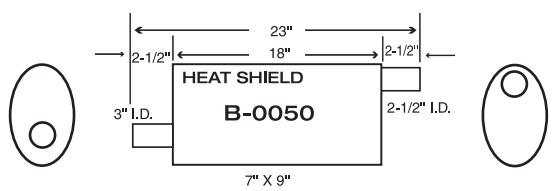

**1992-1995
CHEVROLET/G.M.C.
ASTRO/SAFARI VAN**

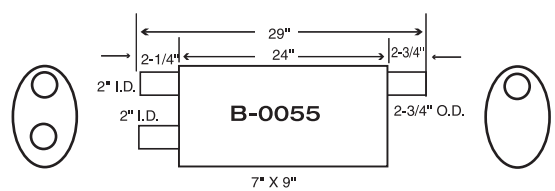

**1996-1998
CHEVROLET/G.M.C.
C1500/2500,
K1500/2500**

NOTE: See page 18 for custom mufflers

UNITED MUFFLER CORP.

U.S. toll free 1-800-247-5391 • Fax 515-224-0727 • website: www.auto-jet.com
 Canada toll free 1-866-229-3402 • Fax 519-455-1103 • website: www.unitedmuffler.com

RUGGED!

HEAVY DUTY
ALL WELDED
ALUMINIZED

MUFFLERS



7" X 9" OVALS

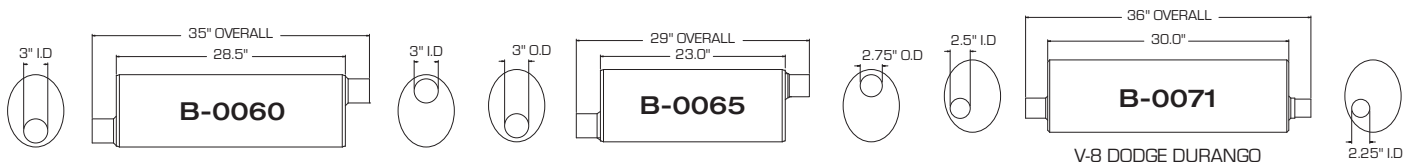

8-1/4" X 11-1/2" OVALS

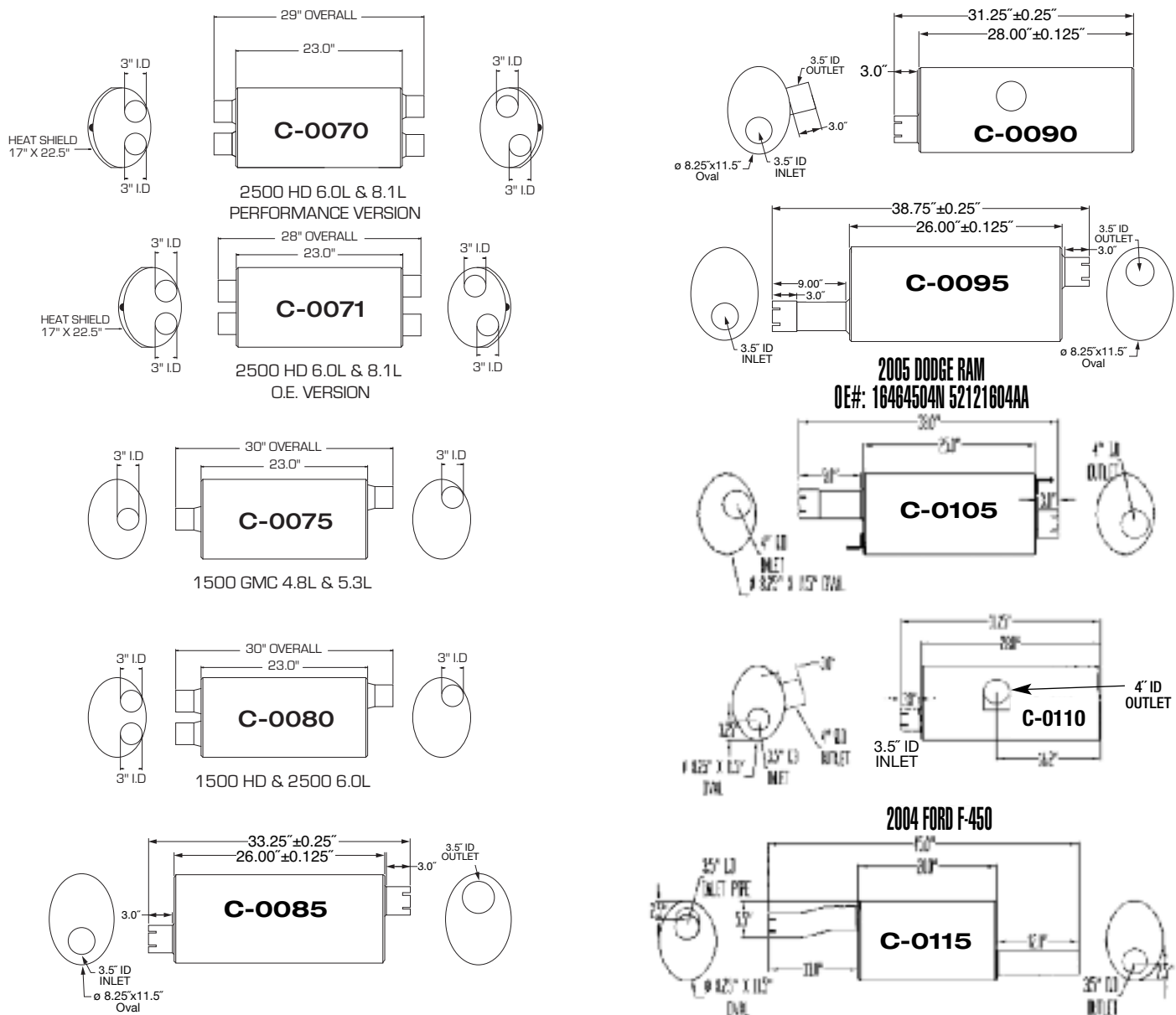

UNITED MUFFLER CORP.

U.S. toll free 1-800-247-5391 • Fax 515-224-0727 • website: www.auto-jet.com
Canada toll free 1-866-229-3402 • Fax 519-455-1103 • website: www.unitedmuffler.com

MUFF 11



MUFFLERS



8-1/4" X 11-1/2" OVALS

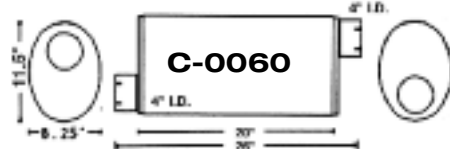
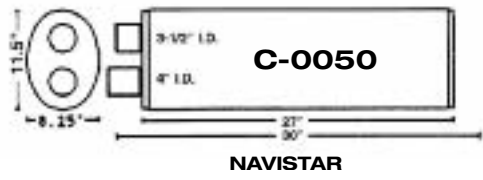
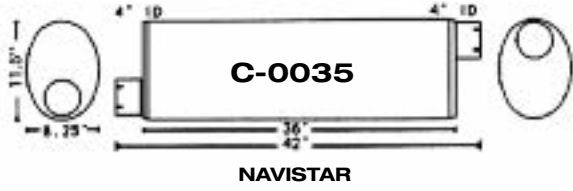
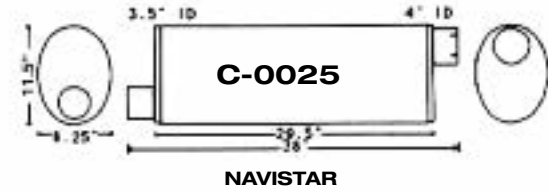
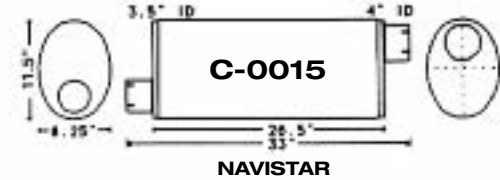
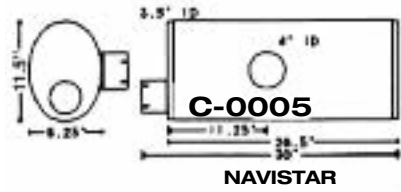
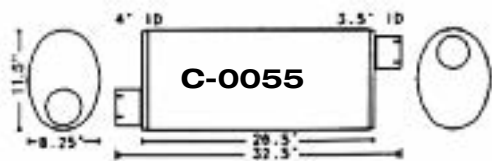
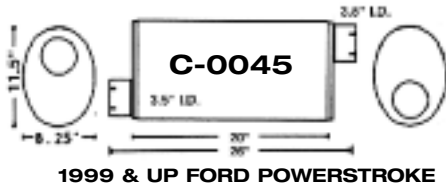
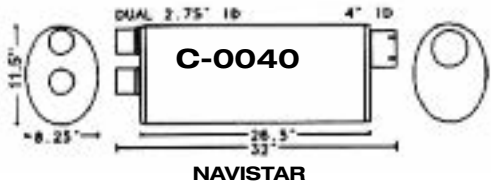
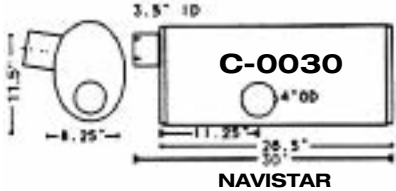
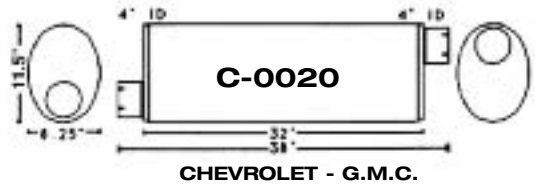
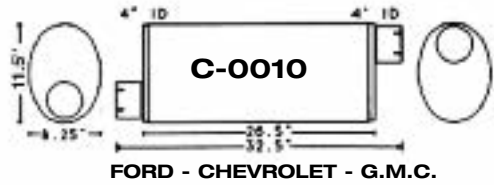

1999 & UP FORD POWERSTROKE
AUTO-JET "HI-FLOW" SYSTEM

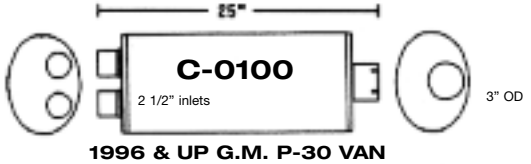

NOTE: See page 18 for custom mufflers

UNITED MUFFLER CORP.

U.S. toll free 1-800-247-5391 • Fax 515-224-0727 • website: www.auto-jet.com
Canada toll free 1-866-229-3402 • Fax 519-455-1103 • website: www.unitedmuffler.com

RUGGED!

HEAVY DUTY
ALL WELDED
ALUMINIZED

NAVISTAR TRUCK MUFFLERS



END INLET - SIDE OUTLET 8-1/4" X 11-1/2" OVALS

**AUTO-JET PART NO.: NAV-0005
SIDE OUTLET**

Navistar Part No. OE 1669749C1
1669751C1

INLET END VIEW

4" OUTLET
10 O'CLOCK
3-1/2" I.D. INLET
6 O'CLOCK



32" CASE
8-1/4 X 11-1/2" OVAL
7" FROM END OF CASE
TO CENTER OF OUTLET

**FOR 6" SHORTER CASE
ORDER NAV-0040**

POPULAR NAVISTAR MUFFLER HANGERS

3/8" Bolt Holes



OVMHIHDT

Engines: DT466-DT360-T444
OE Cross Ref. # 1660540C91

3/4" Bolt Holes

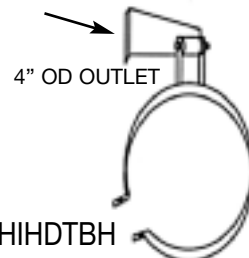

OVMHIHDTBH

Engines: DT466-DT360-T444
OE Cross Ref. # 2013206C91

**AUTO-JET PART NO.: NAV-0010
APPLICATION: DT 360 & DT 466
SIDE OUTLET**

Navistar Part No. OE 1647998C1
New Navistar No. 1657433C1

INLET END VIEW

4" OUTLET
10 O'CLOCK
3-1/2" I.D. INLET
6 O'CLOCK



32" CASE
8-1/4 X 11-1/2" OVAL
12" FROM END OF CASE
TO CENTER OF OUTLET

**AUTO-JET PART NO.: NAV-0015
APPLICATION: DT 360 & DT 466
SIDE OUTLET**

Navistar Part No. OE 1648000C1

INLET END VIEW

4" OUTLET
4 O'CLOCK
3-1/2" I.D. INLET
6 O'CLOCK

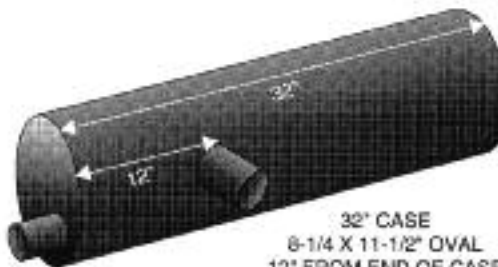

32" CASE
8-1/4 X 11-1/2" OVAL
12" FROM END OF CASE
TO CENTER OF OUTLET



OVMHIH73

Engines: 7.3-6.9 Litre
OE Cross Ref. # 1660543C91

END INLET - END OUTLET SAME END REVERSE FLOW

**AUTO-JET PART NO.: NAV-0020
END INLET - END OUTLET
SAME END - REVERSE FLOW**

INLET END VIEW

3-1/2" INLET
4" OUTLET

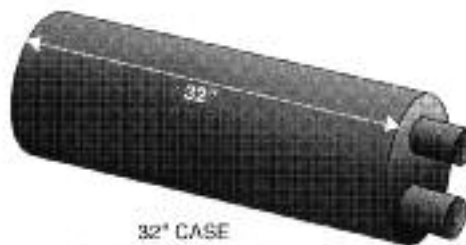

32" CASE
8-1/4 X 11-1/2" OVAL

Popular on
DOT Trucks

4" ID

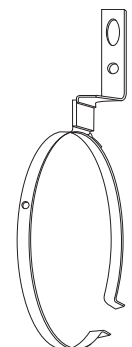

OVMHIHDOT
OE Cross Ref. # 1661881C96

UNITED MUFFLER CORP.

U.S. toll free 1-800-247-5391 • Fax 515-224-0727 • website: www.auto-jet.com
Canada toll free 1-866-229-3402 • Fax 519-455-1103 • website: www.unitedmuffler.com

MUFF 13



NAVISTAR TRUCK MUFFLERS

RUGGED!
HEAVY DUTY
ALL WELDED
ALUMINIZED

8-1/4" X 11-1/2" OVALS

AUTO-JET PART NO.: NAV-0025
APPLICATION: DT360 & DT466
ESPECIALLY FOR HIGHWAY DEPT. TRUCKS
5" SHORTER CASE THAN O.E. 1664453C2

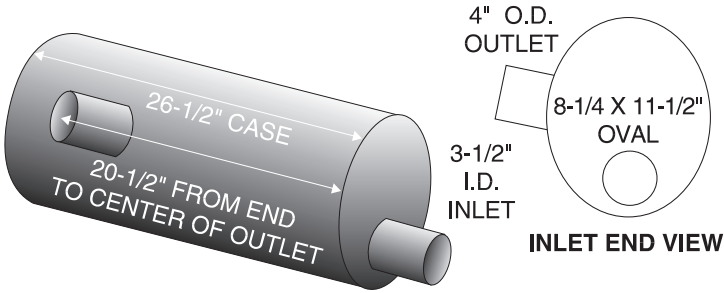

NOTE: See page 13 for Hangers

AUTO-JET PART NO.: NAV-0040
6" SHORTER CASE THAN NAV-0005

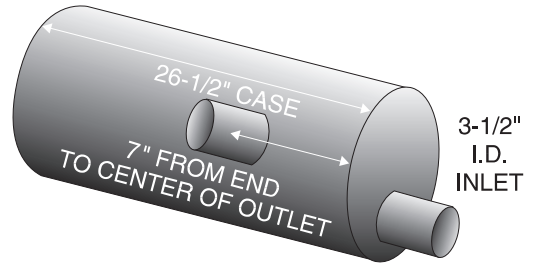

AUTO-JET PART NO.: NAV-0030
APPLICATION: DT360 & DT466
Navistar Part No.: O.E. 1664453C2

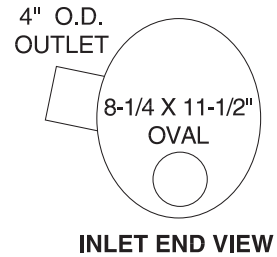
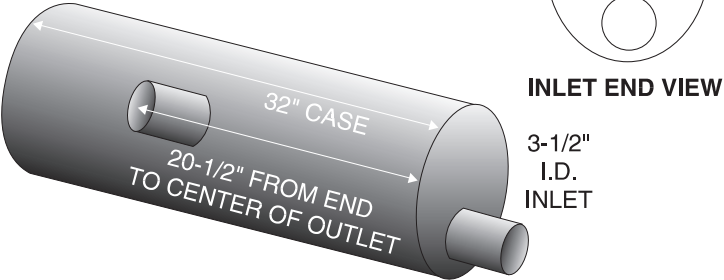

AUTO-JET PART NO.: NAV-0035
END INLET - SIDE OUTLET
Navistar Part No. 578 070 C1

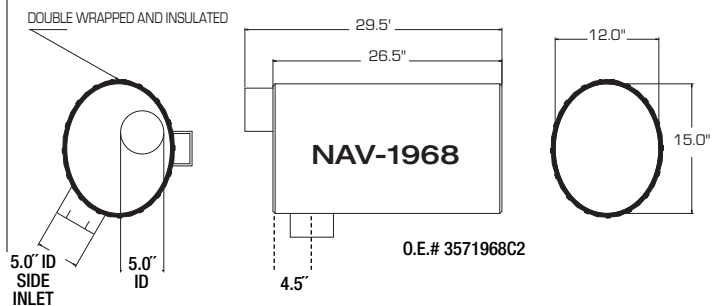
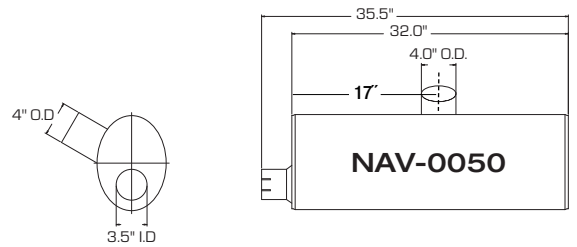
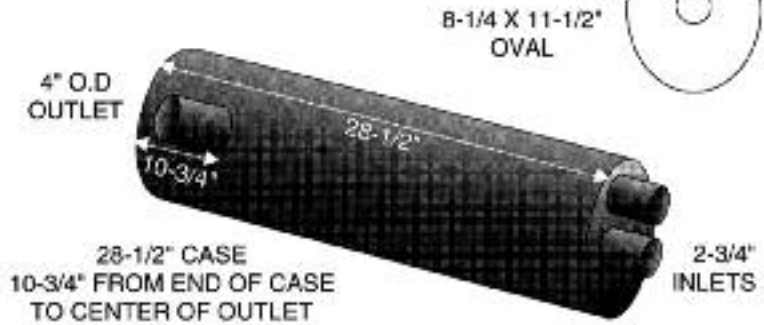

UNITED MUFFLER CORP.

U.S. toll free 1-800-247-5391 • Fax 515-224-0727 • website: www.auto-jet.com
Canada toll free 1-866-229-3402 • Fax 519-455-1103 • website: www.unitedmuffler.com

RUGGED!

HEAVY DUTY
ALL WELDED
ALUMINIZED

MUFFLERS

United 
MUFFLER CORP.
Manufacturing Heavy Duty Mufflers

10" X 15" OVALS

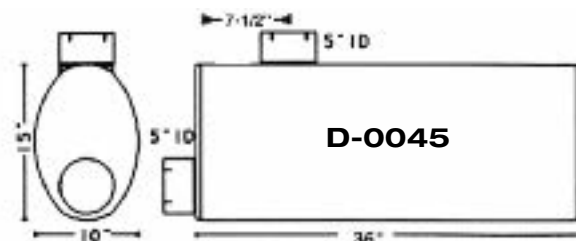
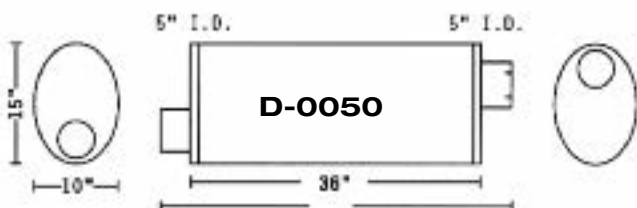
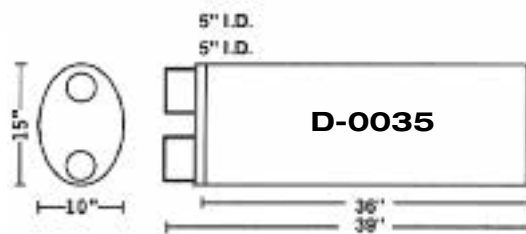
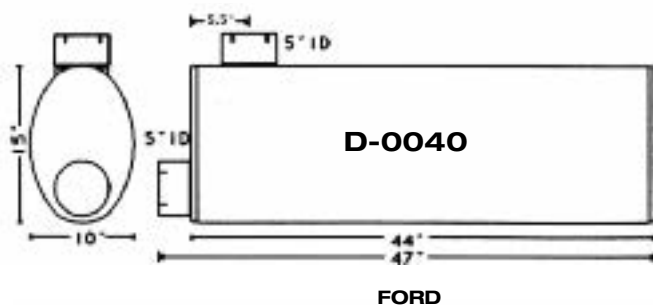
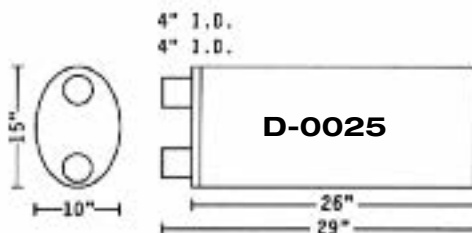
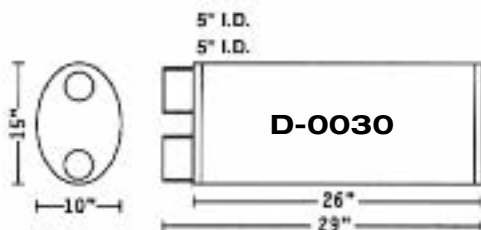
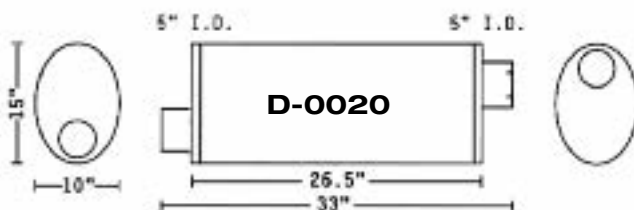
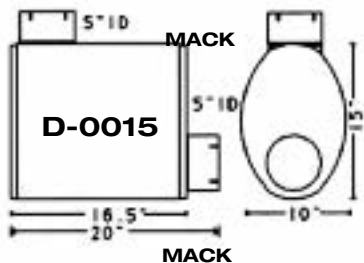
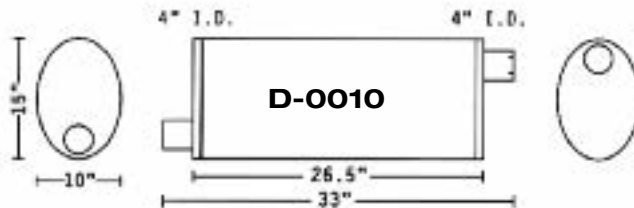
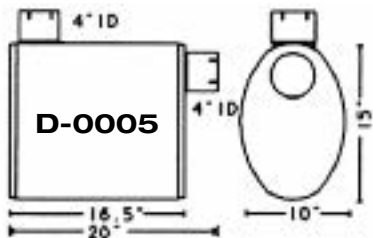

NOTE: See page 18 for custom mufflers

UNITED MUFFLER CORP.

U.S. toll free 1-800-247-5391 • Fax 515-224-0727 • website: www.auto-jet.com
Canada toll free 1-866-229-3402 • Fax 519-455-1103 • website: www.unitedmuffler.com

MUFF 15



MUFFLERS

RUGGED!
HEAVY DUTY
ALL WELDED
ALUMINIZED

10" X 15" OVALS

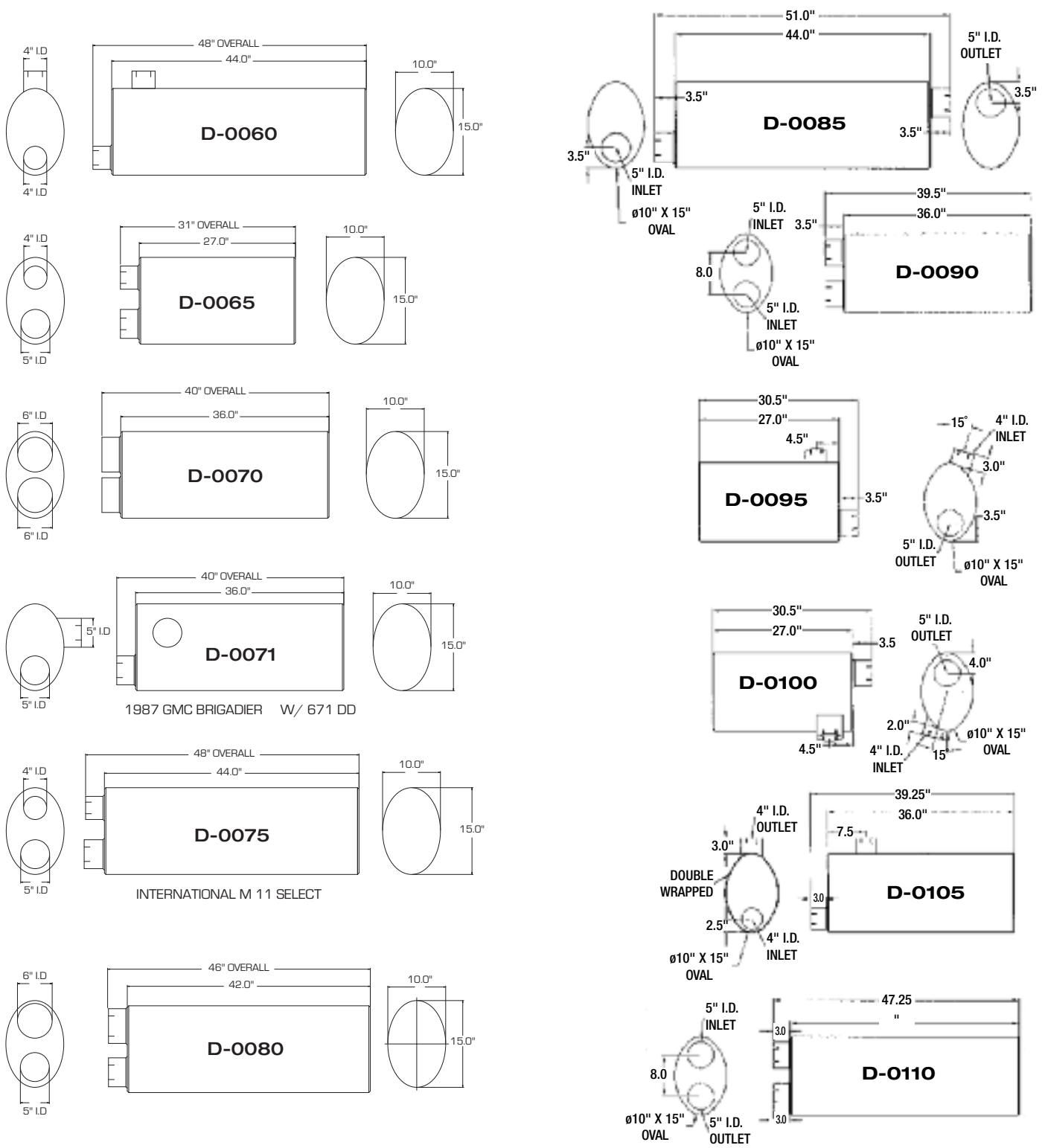

UNITED MUFFLER CORP.

U.S. toll free 1-800-247-5391 • Fax 515-224-0727 • website: www.auto-jet.com
Canada toll free 1-866-229-3402 • Fax 519-455-1103 • website: www.unitedmuffler.com

MUFF 16

RUGGED!

HEAVY DUTY
ALL WELDED
ALUMINIZED

STACK MUFFLERS HEAVY DUTY

United 
MUFFLER CORP.
Manufacturing Heavy Duty Mufflers

VERTICAL 9" DIAMETER

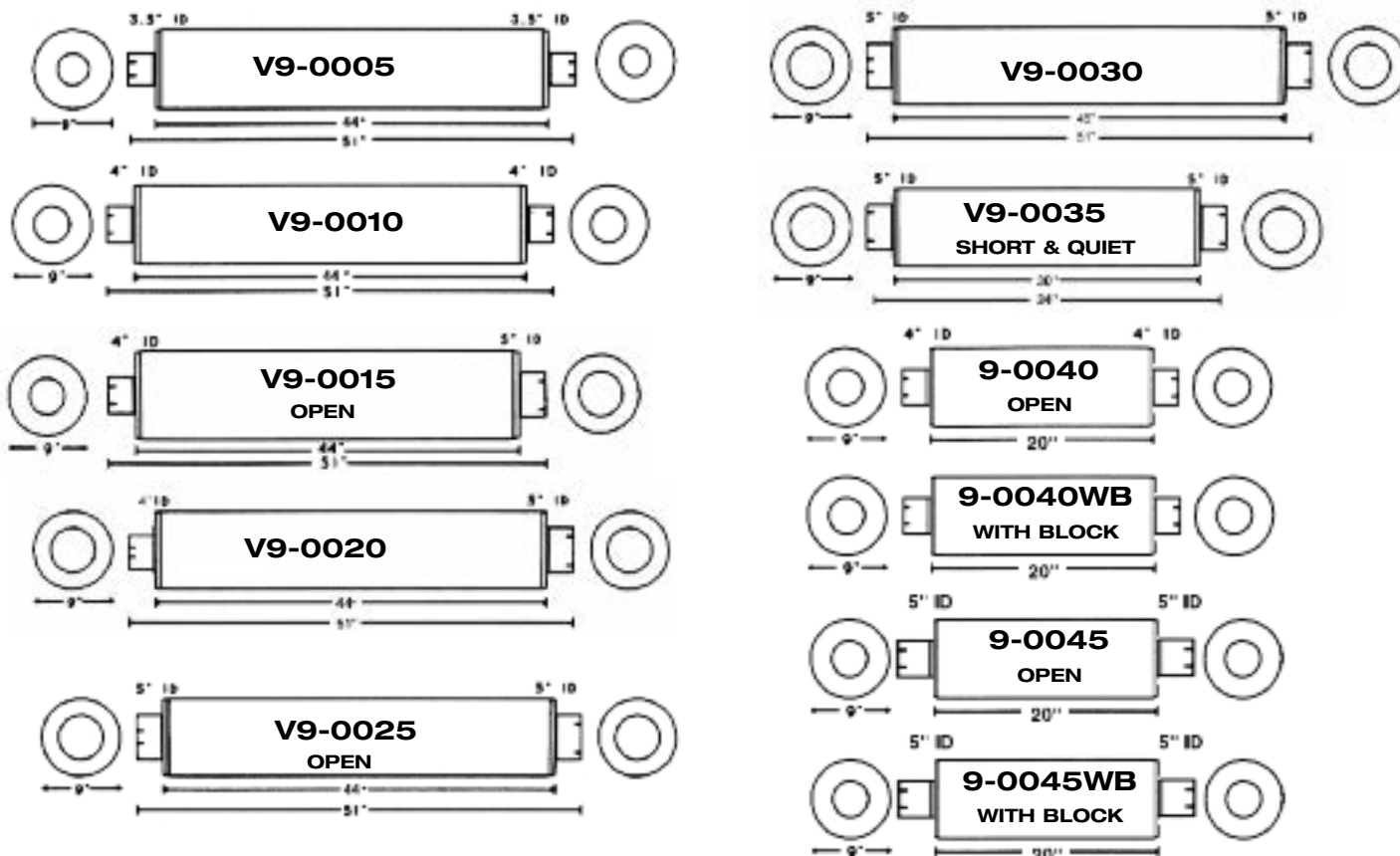

NOTE: OUR HEAVY DUTY MUFFLERS MAY BE USED HORIZONTALLY.

VERTICAL 10" DIAMETER

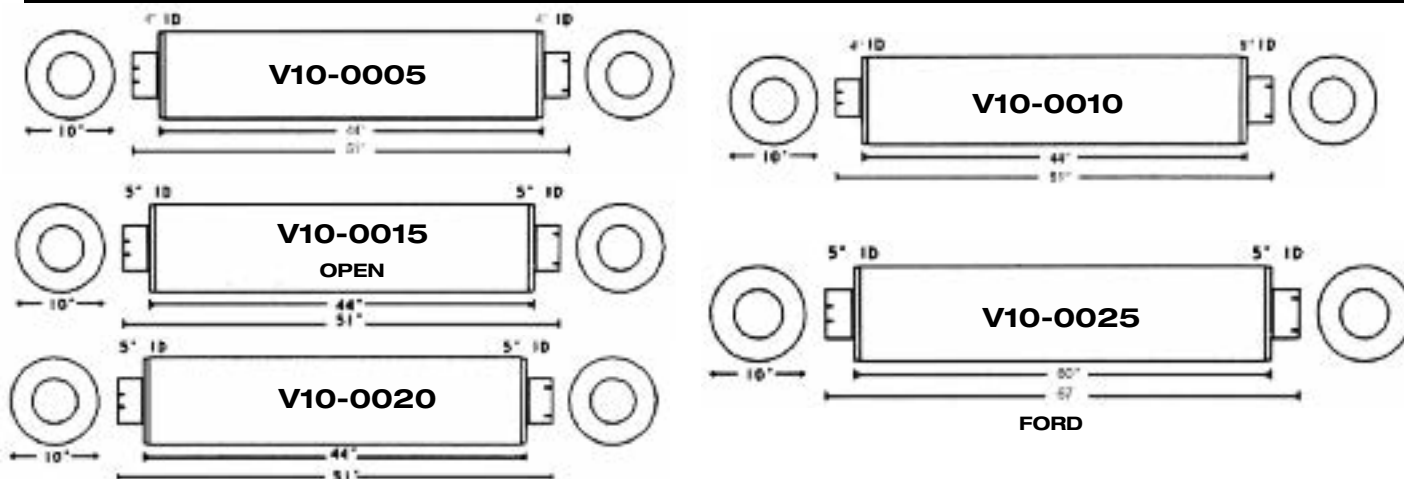

NOTE: OUR HEAVY DUTY MUFFLERS MAY BE USED HORIZONTALLY.

UNITED MUFFLER CORP.

U.S. toll free 1-800-247-5391 • Fax 515-224-0727 • website: www.auto-jet.com
Canada toll free 1-866-229-3402 • Fax 519-455-1103 • website: www.unitedmuffler.com

MUFF 17



MUFFLERS



CUSTOM MUFFLERS

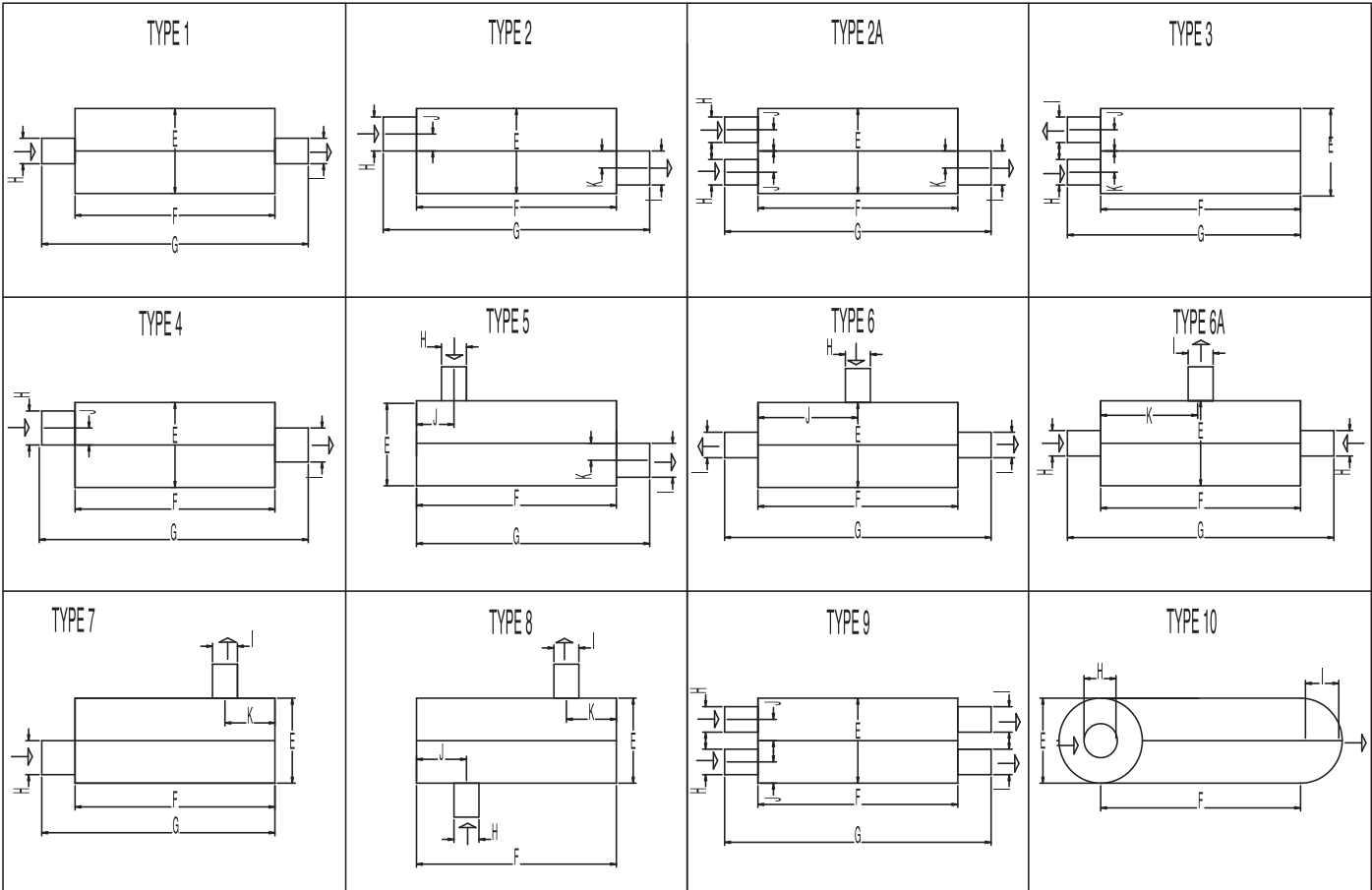

A- MAKE OF VEHICLE :	G- OVERALL LENGTH :
B- ENGINE :	H- INLET SIZE (I.D) OR (O.D) :
C- O.E.# :	I- OUTLET SIZE (I.D) OR (O.D) :
D- MUFFLER TYPE :	J- INLET OFFSET :
E- CASE DIAMETER :	K- OUTLET OFFSET :
F- CASE LENGTH :	CALL TOLL FREE: 1-866-229-3402 OR FAX: 519-455-1103

NOTE: VIEW CLOCK POSITION FROM INLET END ONLY

L- CLOCK POSITION OUTLET

M- CLOCK POSITION INLET

UNITED MUFFLER CORP.

U.S. toll free 1-800-247-5391 • Fax 515-224-0727 • website: www.auto-jet.com
 Canada toll free 1-866-229-3402 • Fax 519-455-1103 • website: www.unitedmuffler.com

MUFFLERS

SPARK ARRESTORS

- Designed for universal application with a minimum of restriction on the engine. They work well as add-on units to existing exhaust systems. Their light-weight small size reduces stress and vibration to the rest of the exhaust system. Typical applications include logging and construction equipment, agricultural machinery, over-the-road trucks, airport equipment, forestry and military vehicles.
- All arrestors exceed U.S. Forestry requirements and are qualified and tested for vertical and horizontal installations under the U.S. Forestry Service Standard 5100-1a.
- All inlets are slotted tube connections. Outlets are O.D. tubing.
- CFM rating is based on a pressure drop of 1 PSI.

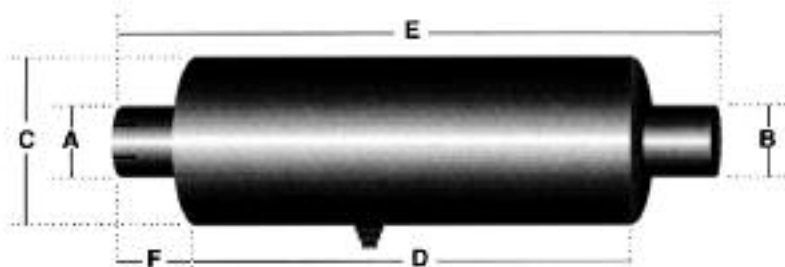

A (I.D.)	B (O.D.)	C	D	E	F	CFM RATING	PART NUMBER
1.05"	1.25"	4.24"	3.2"	5.9"	1.3"	80	49110U
1.50"	1.50"	4.24"	3.1"	5.9"	1.4"	165	49115U
2.00"	2.00"	5.62"	6.4"	11.0"	2.0"	295	49120B
2.50"	2.63"	5.62"	8.6"	12.8"	2.0"	450	49125A
3.00"	3.13"	6.62"	10.2"	14.9"	2.5"	660	49130A
3.50"	3.63"	7.62"	12.0"	17.6"	3.0"	900	49135A
4.00"	4.13"	8.50"	14.6"	21.2"	3.4"	1180	49140A
5.00"	5.13"	9.62"	16.0"	24.0"	4.0"	1840	49150A
6.00"	6.13"	12.12"	22.0"	27.0"	2.0"	2650	49160A

GENERATOR MUFFLERS

INTERNAL SPARK ARRESTOR
 U.S. FORESTRY APPROVED
 USE ON MOTOR HOMES, TRUCKS, ETC.

AUTO-JET PART NO.: GENMUFF

MUFFLER CONSTRUCTION EQUIPMENT & AGRICULTURAL EQUIPMENT

PART NO.	INLET-OUTLET I.D.	BODY DIAMETER	LENGTH	OA
45237	2"	4.38	12.5	17
65071	2-1/2"	6.62	15	22
80018	3"	8.00	12	17
70028	3-1/2"	7.00	14	19.75
90040WB	4"	9.00	20	26.5
90045WB	5"	9.00	20	26.5

INLET AND OUTLET SIZES CAN BE CHANGED.



•HEAVY DUTY ALUMINIZED
 •HAS CENTER BLOCK

UNITED MUFFLER CORP.

U.S. toll free 1-800-247-5391 • Fax 515-224-0727 • website: www.auto-jet.com
 Canada toll free 1-866-229-3402 • Fax 519-455-1103 • website: www.unitedmuffler.com

MUFF 19



CHEVROLET-GMC MUFFLERS

END INLET - END OUTLET (STAINLESS STEEL) ORIGINAL EQUIPMENT MUFFLERS - MED. DUTY

AUTO-JET PART NO.: 2250400BS
APPLICATION: GAS
ENGINE: 366 C.I. - 427 C.I.
YEAR: 1986 TO 1989

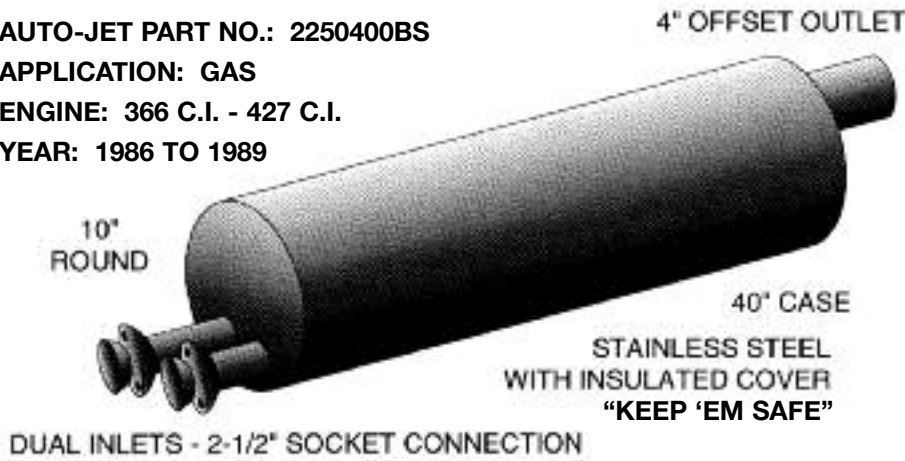

SHIELD HANGER



#GM10HS

MUFFLER HANGER



#GM10MH

FRAME BRACKETS



FRONT
#GM10BRFT



REAR
#GM10BRRE

AUTO-JET PART NO.: 2250300BS
APPLICATION: GAS
ENGINE: 366 C.I. - 427 C.I.
YEAR: 1989 & UP

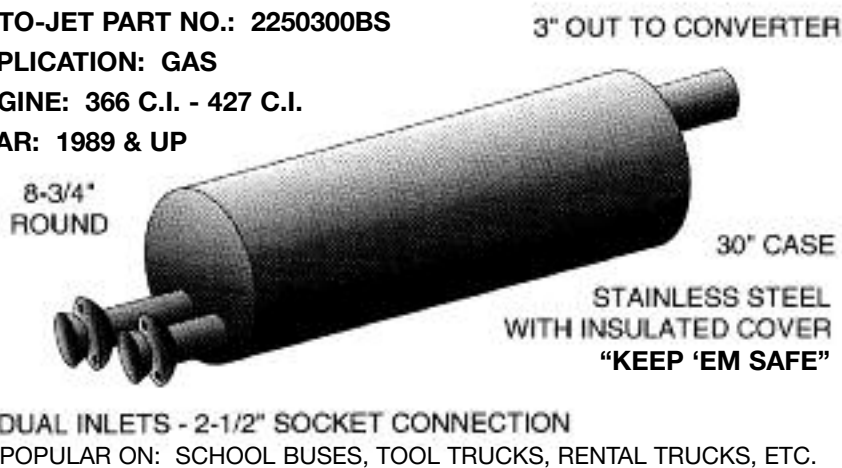

MUFFLER HANGER

#GM875MH



BRACKETS



MUFFLER
#GM875BR



FRAME
#GM875FRBR

AUTO-JET PART NO.: 275275BS
APPLICATION: GAS
ENGINE: 350 C.I., 366-427 C.I.
YEAR: 350 C.I. - 1985 & UP
 366-427 C.I. - 1985 & 1986

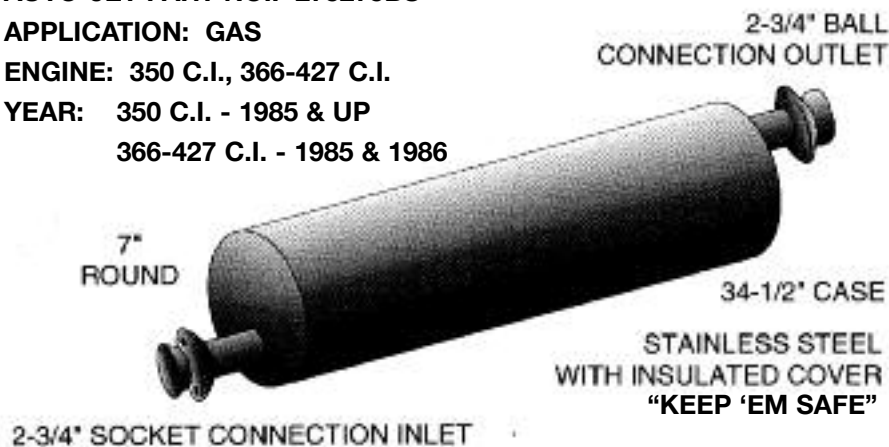

SHIELD

1985 & UP 350 C.I.,
1985 & 1986 366-427 C.I.
WITH TWO MUFFLERS

#GM7SHLD



MUFFLER HANGER



#GM7MH

UNITED MUFFLER CORP.

U.S. toll free 1-800-247-5391 • Fax 515-224-0727 • website: www.auto-jet.com
 Canada toll free 1-866-229-3402 • Fax 519-455-1103 • website: www.unitedmuffler.com

MUFF 20

CHEVROLET - GMC



1998-UP 454-502 C.I. GAS MUFFLERS & STAINLESS STEEL

OE: WELDED
ASSEMBLY WITH
MANIFOLD PIPES



PART #: GM454MUFF
APPLICATION: GAS
ENGINE: 454 C.I. - 502 C.I.
YEAR: 1998 - UP



MUFFLER HANGERS
PART # GM875MH



CONVERTER
PART # GMCONV454



GASKET
PART # GMGS3HOLE

1998-UP GM TRUCK, 6.5 LITRE DIESEL TURBO CONVERTER



2-1/2" Inlet
or
3" Inlet

3" Outlet

3" Outlet

2-1/2" Inlet
3" Inlet

PART # GMCONV651
PART # GMCONV652

GASKET PART #
GMGS3HOLE

UNITED MUFFLER CORP.

U.S. toll free 1-800-247-5391 • Fax 515-224-0727 • website: www.auto-jet.com
Canada toll free 1-866-229-3402 • Fax 519-455-1103 • website: www.unitedmuffler.com

MUFF 21

PICK-UP & VAN CONVERTERS



CHEVROLET - G.M.C

“FLAT PANCAKE”

AUTO-JET PART NO.: GMCONV

APPLICATION: FRONT CONVERTER

ENGINE: GAS 350-366-427 C.I.

YEAR: 1987 & UP

RATED FOR GM LIGHT & MEDIUM

DUTY TRUCKS



FORD

“BIG MOUTH”

AUTO-JET PART NO.: CONVBM2 (2 AIR TUBES)

CONVBM1 (1 AIR TUBE)

APPLICATION: ALL GVW

ENGINE: FORD 351 - 460 C.I.

YEAR: 1988 TO 1993



AUTO-JET PART NO.: CONVFORM32 (2 AIR TUBES)

CONVFORD31 (1 AIR TUBE)

APPLICATION: FORD LIGHT DUTY

ENGINE: 351 - 460 C.I.

YEAR: 1994 & UP

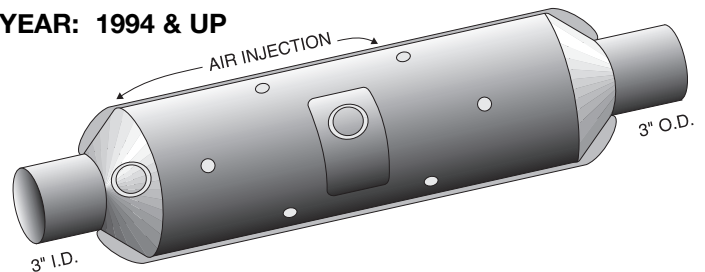

Yes we have
FORD & DODGE
Diesel Pick-Up & Van
Converters!

Please Call!

UNITED MUFFLER CORP.

U.S. toll free 1-800-247-5391 • Fax 515-224-0727 • website: www.auto-jet.com
Canada toll free 1-866-229-3402 • Fax 519-455-1103 • website: www.unitedmuffler.com

MUFF 22

CATALYTIC CONVERTER MUFFLERS

FOR CUMMINS ENGINES

Designed for a wide variety of applications

Donaldson Catalytic Converter Mufflers have been designed in both vertical-mount and horizontal-mount styles to accommodate a wide range of applications. In addition, Donaldson offers custom applications. Call Auto-Jet Muffler Corp. for more information.

STYLE 1

End inlet - end outlet on center

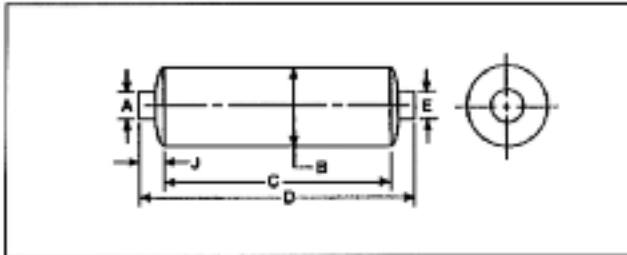

STYLE 3

Side inlet - end outlet

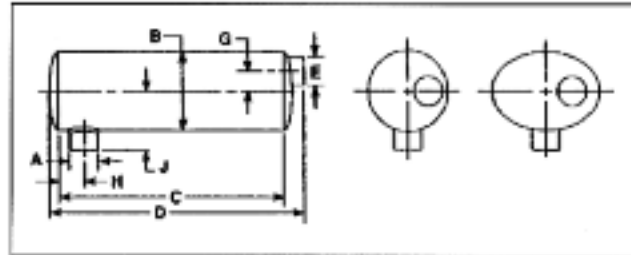

STYLE 4

End inlet - side outlet

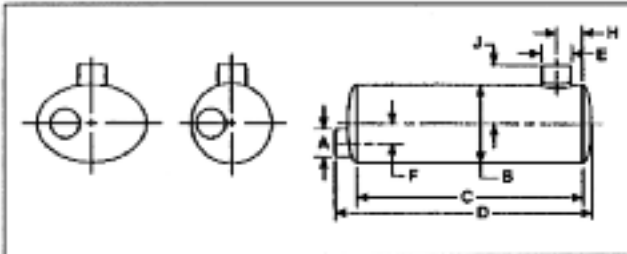

STYLE 6

Side inlet - side outlet

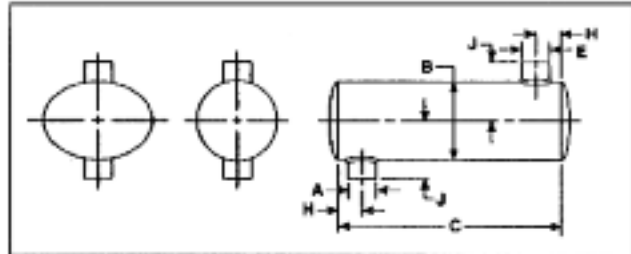

Engine	Part Number	Style	Orientation		Dimensions (in inches)									Backpressure in in. Hg at max hp**
			Conv-Muff	Talpipe	A	B	C	D	E	F	G	H	J	
Cummins 6B5.9L thru 230hp	T400400CAT	1	V*	V*	4.00	10.00	44.50	51.00	4.00	N/A	N/A	N/A	3.00	3.2
	400FDCAT	1	H	H	4.00	11.00	36.00	41.00	4.00	N/A	N/A	N/A	2.00	2.9
	M1110399	4	H	V*	4.00	11.00	36.00	38.00	4.00	0.00	N/A	11.50	8.64	3.1
	M100776	6	H	V*	4.00	10.00	29.00	N/A	4.00	N/A	N/A	4.75	8.00	2.5
Cummins 6C8.3L thru 300hp	400FDCATCV	1	V*	V*	4.00	10.00	44.50	51.00	4.00	N/A	N/A	N/A	3.00	3.2
	400FDCATC	1	H	H	4.00	11.00	36.00	41.00	4.00	N/A	N/A	N/A	2.00	2.8

* Provision has been made in converter muffler design for tailpipe entry water removal per Cummins requirement.
 ** Back pressure listed is for maximum horsepower rating of engine. Lower ratings will produce lower horsepower.
 Cummins limit for total exhaust system back pressure is 4.0" Hg.
 H = horizontal; V = vertical

For more information on warranty, traceability and installation, see the following bulletins:

- 50-372 Warranty Policy
- 1300-119 Catalytic Muffler Traceability
- 1500-182 Installation Guidelines

UNITED MUFFLER CORP.

U.S. toll free 1-800-247-5391 • Fax 515-224-0727 • website: www.auto-jet.com
 Canada toll free 1-866-229-3402 • Fax 519-455-1103 • website: www.unitedmuffler.com

MUFF 23

ACCESSORIES



Nationwide toll free 1-866-229-3402

Fax 519-455-1103 • website: www.unitedmuffler.com

PRODUCTION AND CUSTOM MULTI-BEND TUBES

UP TO 180° DEGREE BENDS & 10FT. LENGTH AVAILABLE

HOSE BEADS AVAILABLE FOR AIR INTAKE, RADIATOR AND CAC TUBES

SEE CHART BELOW FOR CLR & GRIP LENGTH

GRIP = MINIMUM STRAIGHT REQUIRED BETWEEN TANGENTS ON MULTI-BEND TUBES WITHOUT A WELD.

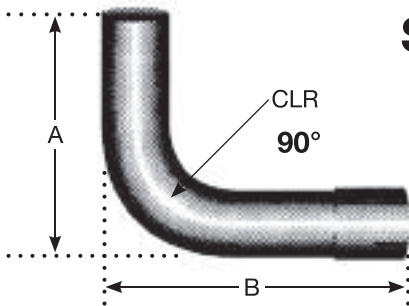

STOCK MANDREL BENDS

STANDARD MATERIAL

16GA ALUMINIZED OR 304 STAINLESS

SPECIFY ENDS

OD-OD, OD-ID OR ID-ID

CHROME AVAILABLE IN

4", 5" & 6" 90° ELBOWS

LEG LENGTHS ± 1/4"

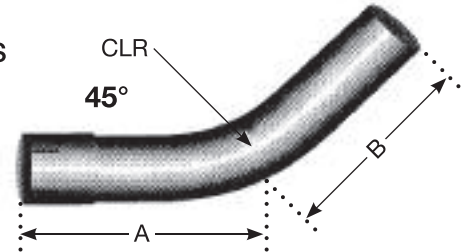

90° MANDREL BENT						45° MANDREL BENT			
SIZE	A	B	CLR	GRIP	PART NUMBER	A	B	CLR	PART NUMBER
1"	6"	6"	1"	4"	10090E	5-1/2"	5-1/2"	1"	10045E
1-1/4"	10"	10"	2"	4"	12590E	6"	6"	2"	12545E
1-1/2"	10"	10"	2"	4"	15090E	6-1/2"	6-1/2"	2"	15045E
1-3/4"	9"	9"	2"	4"	17590E	6-1/2"	6-1/2"	2"	17545E
2"	9-1/2"	9-1/2"	2-1/2"	4"	20090E	6"	6"	2-1/2"	20045E
2-1/2"	9"	9"	3"	4"	25090E	6"	6"	3"	25045E
2-3/4"	12"	12"	4"	4"	27590E				
2-3/4"	12"	12"	2-3/4"	4"	27590ETR	8"	8"	4	27545E
3"	12"	12"	4-1/2"	4"	30090E	7"	7"	4-1/2"	30045E
3"	12"	12"	3-1/2"	4"	30090ETR				
3"	10"	10"	3"	6"	30090ETR3				
3-1/2"	14"	14"	6"	6"	35090E				
3-1/2"	12"	12"	4"	6"	35090ETR	8"	8"	6"	35045E
4"	16"	16"	8"	6"	40090E8				
4"	14"	14"	6"	6"	40090E6	8"	8"	6"	40045E
4"	14"	14"	4-1/2"	6"	*40090ETR				
NEW 4-1/2"	15"	15"	4-1/2"	8"	45090ETR	10"	10"	4-1/2"	45045E
NEW 5"	19"	19"	6"	8"	*50090ETR	12"	12"	6"	50045E
NEW 5"	15"	15"	5"	8"	50090ETR5				
NEW 6"	23"	23"	9"	9"	60090E				
NEW 6"	13"	13"	6"	9"	*60090ETR	13"	13"	6"	60045E

* CHROME AVAILABLE

UNITED MUFFLER CORP.

U.S. toll free 1-800-247-5391 • Fax 515-224-0727 • website: www.auto-jet.com
 Canada toll free 1-866-229-3402 • Fax 519-455-1103 • website: www.unitedmuffler.com

NEW For Our Customers

All Electric CNC State-of-the-Art

UP To 6" Tube Bender

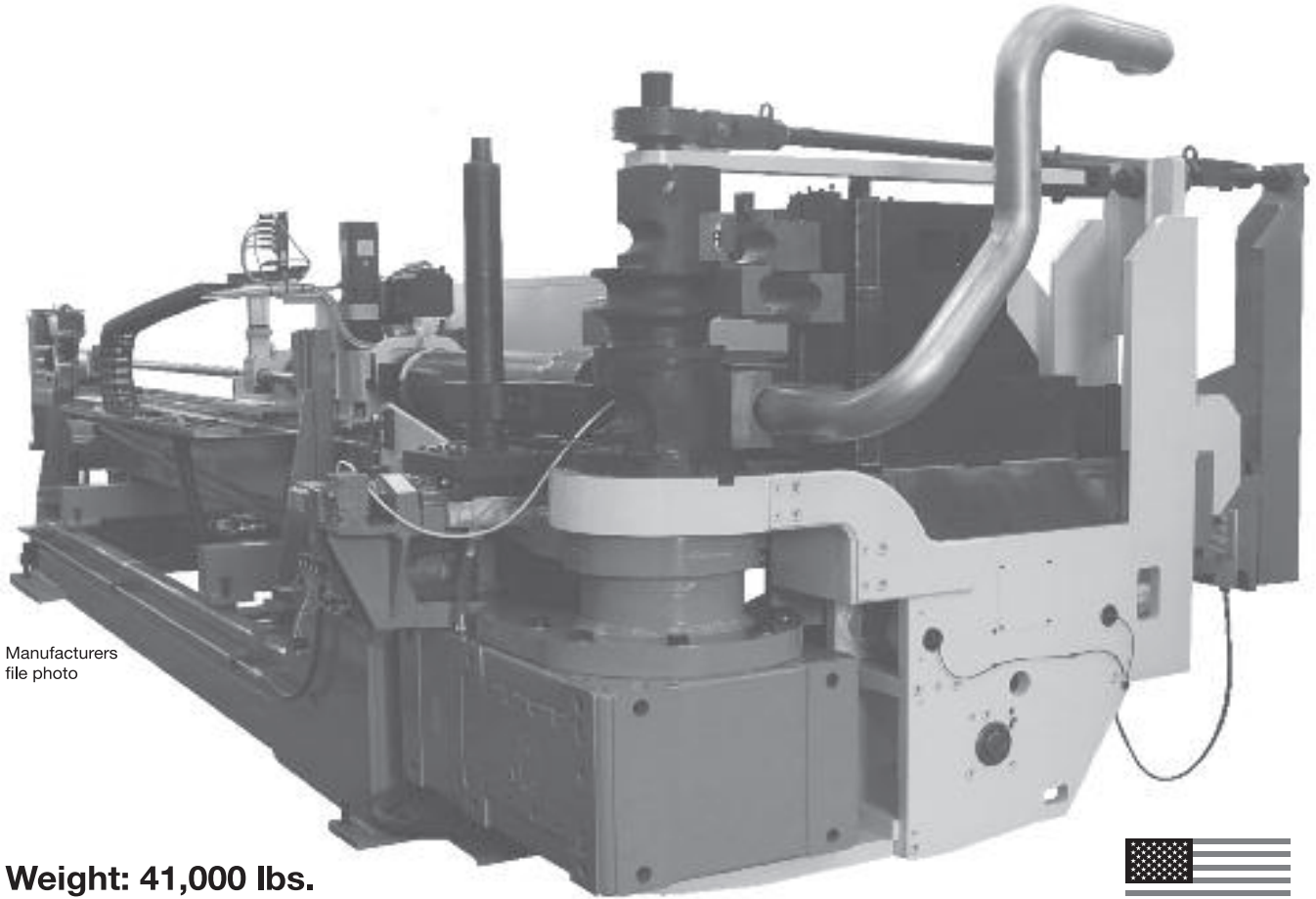

Manufacturers
file photo

Weight: 41,000 lbs.
Up to 180° Bends



Made in U.S.A.

U-BENDS

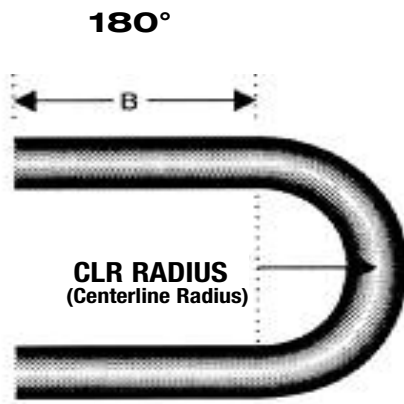

**180° MANDREL BENT
ALUMINIZED OR 304 STAINLESS
FOR STAINLESS ADD 304 TO PART #**

SPECIFY CLR ON 3", 3-1/2" & 4"

PART NO.	GAUGE	TUBE SIZE	RADIUS	A	B
200180E	16	2"	2-1/2"	12	12
250180E	14	2-1/2"	3"	12	12
275180E	14	2-3/4"	4"	12	12
300180E	16	3"	3-1/2" & 4-1/2"	12	12
350180E	16	3-1/2"	4 & 5"	12	12
400180E	16	4"	5 & 6"	12	12
500180E	16	5"	6"	12	12

UNITED MUFFLER CORP.

U.S. toll free 1-800-247-5391 • Fax 515-224-0727 • website: www.auto-jet.com
Canada toll free 1-866-229-3402 • Fax 519-455-1103 • website: www.unitedmuffler.com

ACC 2

TURN DOWNS

ALUMINIZED & CHROME MANDREL BENT



NOTE: For 304 "Polishable" Stainless Add 304 to part number

SIZE	OVERALL LENGTH	O.D. PART NO.	I.D. PART NO.	CHROME I.D. PART NO.	304 STAINLESS (Polishable) I.D. PART NO.
2-3/4"	14"	TD275OD	TD275ID		
3"	14"	TD300OD	TD300ID	TD300C	TD300304
3-1/2"	14"	TD350OD	TD350ID	TD350C	TD350304
4"	14"	TD400OD	TD400ID	TD400C	TD400304
5"	20"	TD500OD	TD500ID	TD500C	TD500304
6"	20"	TD600OD	TD600ID	TD600C	TD600304

GOODY BOX

CRATE OF MANDREL BENDS

- Various degrees and sizes
- 70 bends minimum
- All aluminized or 304 stainless
- Subject to availability
- You can specify sizes, 2" thru 6" (2 minimum)
- These bends are set-ups and errors from our 11 mandrel machines - "We do make mistakes!"



BULL HORNS - MANDREL BENT

MANUFACTURED OUT OF 5' ALUMINIZED TUBE



304 stainless steel available in 3", 3-1/2", 4", and 5" sizes.

OD	CLR	DEGREE	15°	30°	45°	60°	75°
3"	4-1/2"	PART #	BH30015	BH30030	BH30045	BH30060	BH30075
3-1/2"	4 OR 6"	PART #	BH35015	BH35030	BH35045	BH35060	BH35075
4"	4-1/2 OR 6"	PART #	BH40015	BH40030	BH40045	BH40060	BH40075
5"	6"	PART #	BH50015	BH50030	BH50045	BH50060	BH50075

UNITED MUFFLER CORP.

U.S. toll free 1-800-247-5391 • Fax 515-224-0727 • website: www.auto-jet.com
 Canada toll free 1-866-229-3402 • Fax 519-455-1103 • website: www.unitedmuffler.com

STACKS



CURVED

MANDREL BENT ALUMINIZED
PLEASE SPECIFY I.D. OR O.D. ON BOTTOM
ANGLE CUT ALSO IN STOCK
ALSO AVAILABLE IN 304 POLISHABLE STAINLESS STEEL

SIZE	CURVED STACKS - LENGTH & PART NUMBER						
	18"	24"	36"	48"	60"	72"	84"
3"	STAK183	STAK243	STAK363	STAK483	—	—	—
3-1/2"	STAK1835	STAK2435	STAK3635	STAK4835	STAK6035	—	—
4"	STAK184	STAK244	STAK364	STAK484	STAK604	STAK724	STAK844
5"	STAK185	STAK245	STAK365	STAK485	STAK605	STAK725	STAK845



STRAIGHT

ALUMINIZED TUBING
PLEASE SPECIFY I.D. OR O.D. ON BOTTOM
ANGLE CUT ALSO IN STOCK
ALSO AVAILABLE IN 304 POLISHABLE STAINLESS STEEL

SIZE	STRAIGHT STACKS - LENGTH & PART NUMBER							
	18"	24"	36"	48"	60"	72"	84"	96"
3"	STAK183ST	STAK243ST	STAK363ST	STAK483ST	—	—	—	—
3-1/2"	STAK1835ST	STAK2435ST	STAK3635ST	STAK4835ST	STAK6035ST	—	—	—
4"	STAK184ST	STAK244ST	STAK364ST	STAK484ST	STAK604ST	STAK724ST	STAK844ST	STAK964ST
5"	STAK185ST	STAK245ST	STAK365ST	STAK485ST	STAK605ST	STAK725ST	STAK845ST	STAK965ST
6"	STAK186ST	STAK246ST	STAK366ST	STAK486ST	STAK606ST	—	—	—

GUARDS AND CLAMP KITS

MUFFLER GUARD
8-1/2" TO 10-1/8"

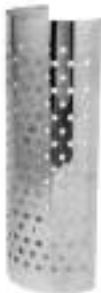

PIPE GUARD
4" & 5" DIAMETER



MUFFLER CLAMP KITS



PIPE GUARD CLAMP KITS



MUFFLER GUARDS A=ROUND HOLES B=SLOTTED HOLES					PIPE GUARD CLAMP KIT		CLAMP KIT		
PART NO.	TYPE	MATERIAL	LENGTH	CIRCLE	PART NO.	PIPE DIA.	PART NO.	MUFFLER DIA.	CIRCLE
89747C	A	STAINLESS	48"	180°	89770K	4	89761K	8-1/2"	180°
89748A	A	ALUMINIZED	48"	180°	89771K	5	89762K	9"	180°
89749C	A	STAINLESS	48"	270°	—	—	89763K	10-1/8"	180°
89995C	B	STAINLESS	48"	270°	PIPE GUARD		89764K	10-1/2"	180°
89996C	B	STAINLESS	48"	180°	89744C(STAINLESS)	4 & 5	89766K	9"	270°
90555C	A	STAINLESS	51"	270°	SP18(ALUMINIZED)	4 & 5	89767K	10-1/8"	270°
90556C	B	STAINLESS	51"	270°	SP18PL(CHROME)	4 & 5	—	—	—

UNITED MUFFLER CORP.

U.S. toll free 1-800-247-5391 • Fax 515-224-0727 • website: www.auto-jet.com
 Canada toll free 1-866-229-3402 • Fax 519-455-1103 • website: www.unitedmuffler.com

CUSTOM DESIGNED TUBE BENDING TOOLING

- Tooling provides smooth bends with a minimum amount of size reduction through the bend.
- All sizes made from aluminized material. Polishable 304 stainless available in 2", 2-1/2", 3", 4", and 5" sizes.
- Tube OD at ends can be sized up or down at least twice metal thickness.
- Auto-Jet has six mandrel machines. Production cycles through all sizes and radiuses in approximately 3 weeks.

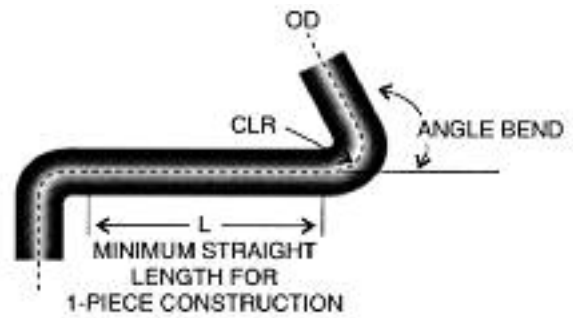

TUBE OD	2"	2-1/2"	2-3/4"	3"	3"	3"	3-1/2"	3-1/2"	4"	4"	4"	5"
CLR	2-1/2"	3"	4"	3"	3-1/2"	4-1/2"	4"	6"	4-1/2"	6"	8"	6"
L	6"	6"	6"	6"	6"	6"	6"	6"	6"	6"	6"	12"
MAX. BEND	180°	180°	120°	120°	180°	180°	180°	180°	180°	180°	120°	180°

Auto-jet's **NEWEST**
MUFFLER CORP.

C.N.C.

MANDREL BENDER



Actual photo of Auto-Jet's "Custom Designed" Tube Bending Tool

BIOGRAPHY: Manufactured in Schmallenberg, Germany

SIZE: 8' Wide x 25' Long x 5' High

WEIGHT: 16,000 LBS.

The computer stores 1 million parts

COST \$: "You Don't Even Want to Know"

WE'LL BEND FOR YOU!

UNITED MUFFLER CORP.

U.S. toll free 1-800-247-5391 • Fax 515-224-0727 • website: www.auto-jet.com
Canada toll free 1-866-229-3402 • Fax 519-455-1103 • website: www.unitedmuffler.com

ACC 5

STRAIGHT TUBING

ANY LENGTH AVAILABLE (20' MAXIMUM)

STANDARD IS OD-OD ENDS

EXPANSIONS ARE AVAILABLE



HEAVY DUTY ALUMINIZED STRAIGHT TUBING STANDARD LENGTH 10'

SIZE	PART NUMBER
2"	200STPA
2-1/4"	225STPA
2-1/2"	250STPA
2-3/4"	275STPA
3"	300STPA
3-1/2"	350STPA
4"	400STPA
4-1/2"	450STPA
5"	500STPA
6"	600STPA
7"	700STPA
8"	800STPA

HEAVY DUTY COLD ROLLED STRAIGHT TUBING STANDARD LENGTH 10'

SIZE	PART NUMBER
1"	100STP
1-1/4"	125STP
409 STAINLESS "BENDS NICELY"	
2-1/4"	225STP409*
2-1/2"	250STP409*

* ESPECIALLY FOR MUFFLER SHOPS
COMPRESSION BENDS

FLEX TUBING (STAINLESS STEEL)

ANY LENGTH AVAILABLE

STAINLESS STEEL FLEX TUBING STANDARD LENGTH 10'

SIZE	PART NUMBER
1-1/4"	FLEX125SS
1-1/2"	FLEX150SS
1-3/4"	FLEX175SS
2"	FLEX200SS
2-1/2"	FLEX250SS
3"	FLEX300SS
3-1/2"	FLEX350SS
4"	FLEX400SS
5"	FLEX500SS
6"	FLEX600SS



STAINLESS STEEL FLEX TUBING CUT LENGTHS

SIZE	12"	18"	24"	36"
2-3/4"	FLEX27512	FLEX27518	FLEX27524	FLEX27536
3"	FLEX30012	FLEX30018	FLEX30024	FLEX30036
3-1/2"	FLEX35012	FLEX35018	FLEX35024	FLEX35036
4"	FLEX40012	FLEX40018	FLEX40024	FLEX40036
5"	FLEX50012	FLEX50018	FLEX50024	FLEX50036
6"	FLEX60012	FLEX60018	FLEX60024	FLEX60036

UNITED MUFFLER CORP.

U.S. toll free 1-800-247-5391 • Fax 515-224-0727 • website: www.auto-jet.com
 Canada toll free 1-866-229-3402 • Fax 519-455-1103 • website: www.unitedmuffler.com

ACC 6

304 STAINLESS STEEL TUBING



HEAVY DUTY

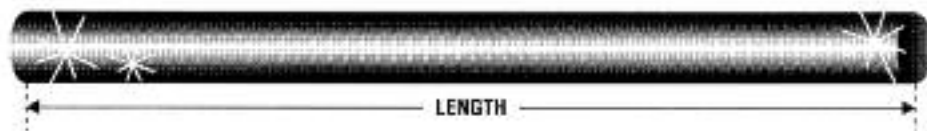

FEATURES:

- Bright Finish
- Polishable to Mirror Finish
- Anti-Magnetic
- Expandable Ends
- 16 G.A. Material
- Withstands Heat to 2100°
- Will Not Rust
- No Minimum
- 10' & 20' Lengths Available

PERFECT FOR:

- Performance Cars
- Show Cars
- Street Rods
- High-temp Applications

NOTE: 316 STAINLESS ALSO AVAILABLE, 100 FT. MIN. 2" COMPRESSION-BENDS NICELY!

5' LENGTH		7.5' LENGTH	
SIZE	304 PART NO.	SIZE	304 PART NO.
2"	200STP304	2"	200STP30475
2-1/2"	250STP304	2-1/2"	250STP30475
3"	300STP304	3"	300STP30475
3-1/2"	350STP304	3-1/2"	350STP30475
4"	400STP304	4"	400STP30475
5"	500STP304	5"	500STP30475*
6"	600STP304	6"	600STP30475

* 5" 304 STAINLESS HAS A DULL FINISH, BUT POLISHABLE TO MIRROR FINISH

UNITED MUFFLER CORP.

U.S. toll free 1-800-247-5391 • Fax 515-224-0727 • website: www.auto-jet.com
Canada toll free 1-866-229-3402 • Fax 519-455-1103 • website: www.unitedmuffler.com

ACC 7

CLAMPS

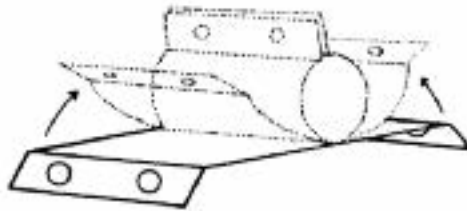

HEAVY DUTY 3/8" BOLT • 10 GA • SADDLE U-BOLT		U-BOLTS 304 STAINLESS	DONALDSON STAINLESS STEEL SEAL CLAMPS		TORC-TITE PRE-FORMED STAINLESS STEEL BAND CLAMPS	
SIZE	PART NUMBER	PART NUMBER	SIZE	PART NUMBER	SIZE	PART NUMBER
2"	U-200	U-200SS	2"	200SC	2"	200SCPF
2-1/4"	U-225	U-225SS	2-1/4"	225SC	2-1/4"	225SCPF
2-1/2"	U-250	U-250SS	2-1/2"	250SC	2-1/2"	250SCPF
2-3/4"	U-275	—	2-3/4"	275SC	2-3/4"	275SCPF
3"	U-300*	U-300SS	3"	300SC	3"	300SCPF*
3-1/2"	U-350*	U-350SS	3-1/2"	350SC	3-1/2"	350SCPF*
4"	U-400*	U-400SS	4"	400SC	4"	400SCPF*
4-1/2"	U-450	—	5"	500SC	5"	500SCPF*
5"	U-500*	U-500SS	6"	600SC	6"	600SCPF
5-1/5"	U-550	—	—	—	—	—
6"	U-600*	—	—	—	—	—

NOTE: 3 " THRU 6" ZINC PLATED

* Available with Gasket
ADD WG to Part #

AccuSEAL™ CLAMPS

ALUMINIZED

- New clamp technology provides simple, effective way to replace U-bolt and guillotine clamps.
- Creates over a ton of clamping force without crushing pipes, resulting in strong, serviceable joint.
- Pre-assembled hardware.
- Fast, easy and accurate installation – slip clamp over slotted side of joint, insert mating pipe and torque to 40-60 ft-lbs.



SIZE	PART NUMBER
2-1/2"	87190L
2-3/4"	87290L
3"	87390L
3-1/2"	87490L
4"	87590L
5"	87790L
6"	87890L

UNITED MUFFLER CORP.

U.S. toll free 1-800-247-5391 • Fax 515-224-0727 • website: www.auto-jet.com
Canada toll free 1-866-229-3402 • Fax 519-455-1103 • website: www.unitedmuffler.com

STAINLESS STEEL BELLOWS ASSEMBLY



FEATURES:

- ONE PIECE LEAK PROOF
- ELIMINATES VIBRATION
- DESIGNED FOR EXTREME HEAT
- ALLOWS EXHAUST SYSTEM FLEXIBILITY
- ID BOTH ENDS
- 304 STAINLESS STEEL
- DOUBLE WALL



OTHER SIZES & LENGTHS AVAILABLE

DESCRIPTION	LENGTH	PART NUMBER
2"	6"	SSB200
2-1/2"	10"	SSB250
3"	12"	SSB30012
3-1/2"	12"	SSB35012
4"	12"	SSB40012
5"	10"	SSB500

REDUCERS - 16 GAUGE ALUMINIZED STEEL



SMALLER SIZES ALSO AVAILABLE

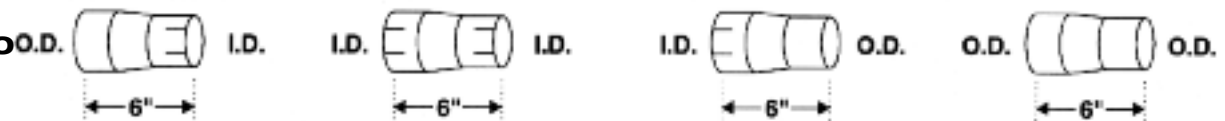

SIZE	OD-ID PART NUMBER	ID-ID PART NUMBER	ID-OD PART NUMBER	OD-OD PART NUMBER
3 X 2-1/2"	3-250 OD-ID	3-250 ID-ID	3-250 ID-OD	3-250 OD-OD
3 X 2-3/4"	3-275 OD-ID	3-275 ID-ID	3-275 ID-OD	3-275 OD-OD
3-1/2 X 3"	350-3 OD-ID	350-3 ID-ID	350-3 ID-OD	350-3 OD-OD
4 X 3"	4-3 OD-ID	4-3 ID-ID	4-3 ID-OD	4-3 OD-OD
4 X 3-1/2"	4-350 OD-ID	4-350 ID-ID	4-350 ID-OD	4-350 OD-OD
4-1/2 X 4"	450-4 OD-ID	450-4 ID-ID	450-4 ID-OD	450-4 OD-OD
5 X 4"	5-4 OD-ID	5-4 ID-ID	5-4 ID-OD	5-4 OD-OD
5 X 4-1/2"	5-450 OD-ID	5-450 ID-ID	5-450 ID-OD	5-450 OD-OD
5-1/2 X 4"			550-4 ID-OD	
6 X 4"			6-4 ID-OD	
6 X 5"	6-5 OD-ID	6-5 ID-ID	6-5 ID-OD	6-5 OD-OD

STRAIGHT CONNECTORS



16 GAUGE ALUMINIZED

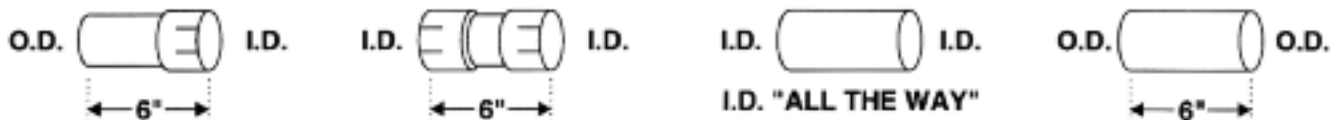

SIZE	OD-ID PART NUMBER	ID-ID PART NUMBER	SLEEVE PART NUMBER	OD-OD PART NUMBER
2-3/4"	275 OD-ID	275 ID-ID	275S	275 OD-OD
3"	300 OD-ID	300 ID-ID	300S	300 OD-OD
3-1/2"	350 OD-ID	350 ID-ID	350S	350 OD-OD
4"	400 OD-ID	400 ID-ID	400S	400 OD-OD
5"	500 OD-ID	500 ID-ID	500S	500 OD-OD
6"	600 OD-ID	600 ID-ID		600 OD-OD

UNITED MUFFLER CORP.

U.S. toll free 1-800-247-5391 • Fax 515-224-0727 • website: www.auto-jet.com
 Canada toll free 1-866-229-3402 • Fax 519-455-1103 • website: www.unitedmuffler.com

V-CLAMPS AND LIP FLARES



V-CLAMP

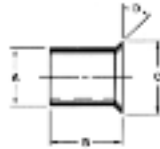

LipFLARE



CUMBNF



3208BEAD



DD6V8VMF

APPLICATION	V-CLAMP	FLARE	LIP FLARE DIMENSIONS			
			A	B	C	D
FORD 370-429 C.I.	370VCL	370FLARE	2-1/2"	4"	3-11/16"	45°
FORD 477-534 C.I.	534VCL	534FLARE	3" I.D.	3"	3-7/8"	20°
FORD 8.2L 501 C.I. NAT ASP. DETROIT	82VFCLNA	82FLARE	3" O.D.	3"	3-7/8"	20°
FORD 8.2L DETROIT TURBO	82FVCLT	82FLARET	4"	3-1/2"	4-5/8"	20°
FORD 6.6 & 7.8L TURBO	66FVCL	66FLARET	3-1/2"	3-1/2"	4-1/16"	20°
FORD 3208 TURBO	3208VCLT	3208FLARE	3-1/2"	3-1/2"	4"	20°
INT. DT-466	DT466VCL	DT466FLARE	3-1/2"	3-1/2"	4-1/16"	20°
INT. DT-360	DT360VCL	DT360FLARE	3-1/2"	3-1/2"	4-1/16"	20°
CUMMINS 8.3 TURBO C-SERIES	83VCLT	8.3CUMFL (MACHINED FLARE)	3-7/8"	2-1/8"	4"	20°
CUMMINS V-555	555VCL	555FLARE	3" I.D.	3"	3-3/4"	20°
CUMMINS 4BT-6BT-5.9L B-SERIES	TCVCL	CUMBMF (MACHINED FLARE)	3"	3"	—	—
CAT 3208 NAT. ASP.	3208FL (FLANGE)	3208BEAD (BEADED ADAPTER)	2-3/4"	3"	BEAD	—
CAT 3208 TURBO	3208VCLT	3208FLARET	3-1/2"	3-1/2"	4"	20°
DETROIT DIESEL TURBO	DD6V8VCL	DD6V8VMF (MACHINED FLARE)	FITS:	8V71T 8V92T	16V71T 6V92T	16V92T
CAT 3126 TURBO	3116VCL	3126FLARE	4"	2"	4-9/16"	22°
CAT 3116 TURBO	3116VCL	3116FLARE	4"	2"	4-9/16"	22°
NAVISTAR T444 - 3"	T444VCL	T444FLARE	3"	2-1/2"	3-11/16"	20°
NAVISTAR T444 - 3-1/2"	-	T444FLARE35	3-1/2"	2"	4-1/2"	22°
250 CUMMINS	51389K	96589K	4"	5"	4-1/2"	45°
CUMMINS	51489K	96689K	5"	5"	5-1/2"	45°
T-50 TURBO CHARGER	50389K	96789K	5"	3"	5-3/4"	18°
-	-	56990A	5"	3"	5-1/2"	22°
JOHN DEERE TURBO	JDVCL	JDFLARE	3-1/2"	2"	4.315"	20°



UNITED MUFFLER CORP.

U.S. toll free 1-800-247-5391 • Fax 515-224-0727 • website: www.auto-jet.com
 Canada toll free 1-866-229-3402 • Fax 519-455-1103 • website: www.unitedmuffler.com

ACC 10

MUFFLER HANGERS

ROUND



OVAL



SIZE	6"	7"	8"	8-1/2"	10"	11"	SIZE	8-1/4" X 11-1/2"	10' X 15"
PART #	600MH	700MH	800MH	850MH	1000MH	1100MH	PART #	OVALMH1	OVALMH2

RAIN CAPS

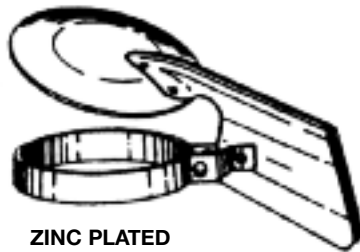

ZINC PLATED

SIZE	PART NUMBER
2-1/2"	RC250
3"	RC300
3-1/2"	RC350
4"	RC400
5"	RC500
6"	RC600
8"	RC800
10"	RC1000

SPLITTER TEE ADAPTER

CONVERTS A SINGLE SYSTEM EXHAUST PIPE INTO A DUAL SYSTEM

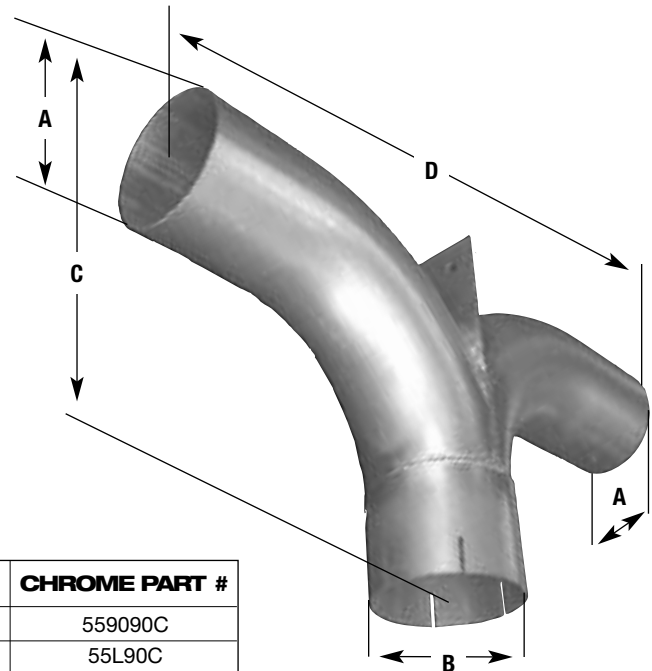

A(O.D.)	B (I.D.)	C	D	ALUMINOZED PART #	CHROME PART #
4"	4"	11-1/4"	16"	559090A	559090C
5"	5"	14"	25"	55L90A	55L90C

UNITED MUFFLER CORP.

U.S. toll free 1-800-247-5391 • Fax 515-224-0727 • website: www.auto-jet.com
 Canada toll free 1-866-229-3402 • Fax 519-455-1103 • website: www.unitedmuffler.com

PETERBILT

PART #: PB-13055Y
OE #: 14-13055

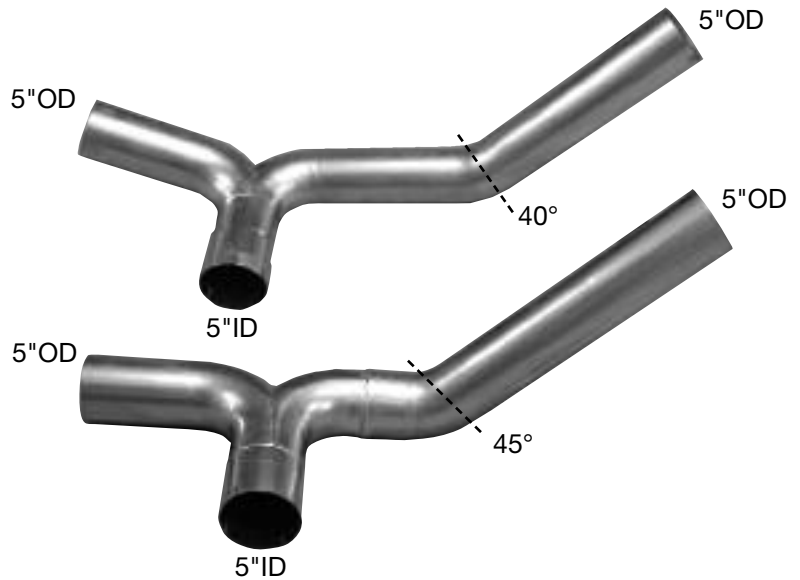

PART #: PB-04055Y
OE #: 14-04055

FREIGHTLINER



PART #: FL-12104
OE #: A04-12104-000

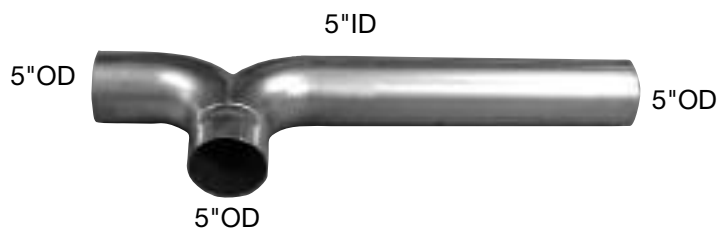

PART #: FL-13974
OE #: A04-13974-000

KENWORTH

PART #: YKW4766
OE #: K180-14766



UNITED MUFFLER CORP.

U.S. toll free 1-800-247-5391 • Fax 515-224-0727 • website: www.auto-jet.com
Canada toll free 1-866-229-3402 • Fax 519-455-1103 • website: www.unitedmuffler.com

CHROME STACK PIPES

FEATURES

- Original equipment quality.
No wavy reflections, grinding lines or pits.
- Double nickel plating before chrome finish prevents corrosion.
- Multiple polishing of base tube before plating assures a high lustre mirror finish.
- No clamp die-marks, saw cut offs or burrs.
All end forming is finished before plating.
- Special packaging prior to shipment with non-marring materials.



- Also available in 304 polishable stainless steel. **STRAIGHT CURVED MITERED 6" X 5"**

SIZE	LENGTH	STRAIGHT O.D.	STRAIGHT I.D. SLOTTED	CURVED O.D.	CURVED I.D. SLOTTED	MITERED WEST COAST
4"	18"	418OSTC	418ISTC	418CCO	418CCI	M418WCC
	24"	424OSTC	424ISTC	424CCO	424CCI	M424WCC
	36"	436OSTC	436ISTC	436CCO	436CCI	M436WCC
	48"	448OSTC	448ISTC	448CCO	448CCI	M448WCC
	60"	460OSTC	460ISTC	460CCO	460CCI	M460WCC
	72"	472OSTC	472STC	472CCO	472CCI	M472WCC
	84"	484OSTC	484STC	484CCO	484CCI	M484WCC
5"	96"	496OSTC	496ISTC	496CCO	496CCI	M496WCC
	18"	518OSTC	518STC	518CCO	518CCI	M518WCC
	24"	524OSTC	524ISTC	524CCO	524CCI	M524WCC
	36"	536OSTC	536ISTC	536CCO	536CCI	M536WCC
	48"	548OSTC	548ISTC	548CCO	548CCI	M548WCC
	60"	560OSTC	560ISTC	560CCO	560CCI	M560WCC
	72"	572OSTC	572ISTC	572CCO	572CCI	M572WCC
	84"	584OSTC	584ISTC	584CCO	584CCI	M584WCC
	96"	596OSTC	596ISTC	596CCO	596CCI	M596WCC
	108"	5108OSTC	5108ISTC	5108CCO	5108CCI	M5108WCC

**6"
CHROME
AVAILABLE
ON REQUEST**

UNITED MUFFLER CORP.

U.S. toll free 1-800-247-5391 • Fax 515-224-0727 • website: www.auto-jet.com
Canada toll free 1-866-229-3402 • Fax 519-455-1103 • website: www.unitedmuffler.com

ACC 13

CHEVROLET - GMC ACCESSORIES

SOLID STAINLESS EXHAUST RINGS 454 C.I. & 366 C.I.



1998 & UP 454 C.I.
SOLID 304 STAINLESS STEEL
PART # 454ER304



ELIMINATES LEAKS
WILL NOT BLOW OUT
WILL NOT CRUSH

1985-UP 366 C.I., 427 C.I. ENGINES
SOLID 304 STAINLESS
PART #366ER304



ELIMINATES LEAKS
WILL NOT BLOW OUT
WILL NOT CRUSH

UNITED MUFFLER CORP.

U.S. toll free 1-800-247-5391 • Fax 515-224-0727 • website: www.auto-jet.com
Canada toll free 1-866-229-3402 • Fax 519-455-1103 • website: www.unitedmuffler.com

ACC 14

TOOLS OF THE TRADE

AUTO-JET LARGE PIPE SHAPER



PART NO.: 400SHAPER

- Designed especially for late model gas or diesel trucks and buses.
- For use on all 2-3/4" thru 4" pipe.
- An essential tool for all garages.
- Heavy duty construction with removable handle.

AUTO-JET TUBING EXPANDER



3-1/2" PART NO.: EXPANDER350
4" PART NO.: EXPANDER4
5" PART NO.: EXPANDER5

- Designed especially for buses and trucks with 4" & 5" exhaust systems.
- Rounds muffler and tubing ends to original size and shape with ease.
- Removes U-bolt crimps.
- Not designed to swage tubing.
- Saves exhaust installation time.
- Operates with impact wrench.
- Replacement parts in stock.

PIPE CUTTERS

**PART NO.: PIPECUT1
UP TO 3"**



**PART NO.: PIPECUT2
UP TO 4"**

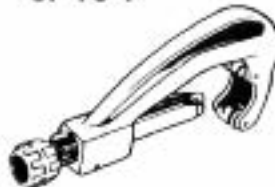

**PART NO.: PIPECUT3
4" TO 6-1/2"**



**PIPE CUTTER
PINS & WHEELS**

- # PIN1
- # PIN2
- # WHEEL



**SHAPER
2" TO 3" SHAPER**

- # SHAPER



**MUFFLER
CEMENT**

- # CEMENT



**EXPANDER FOR
2-1/2" TO 3" PIPE**

- # EXPANDER

UNITED MUFFLER CORP.

U.S. toll free 1-800-247-5391 • Fax 515-224-0727 • website: www.auto-jet.com
Canada toll free 1-866-229-3402 • Fax 519-455-1103 • website: www.unitedmuffler.com

GARAGE EXHAUST HOSE

CRUSH PROOF RUBBER
CAN BE JOINED
AVAILABLE IN 11' LENGTHS



SIZE	PART NUMBER
3'	RH300
4'	RH400
5'	RH500
6'	RH600

RUBBER TAIL PIPE ADAPTER

WITH CHAIN

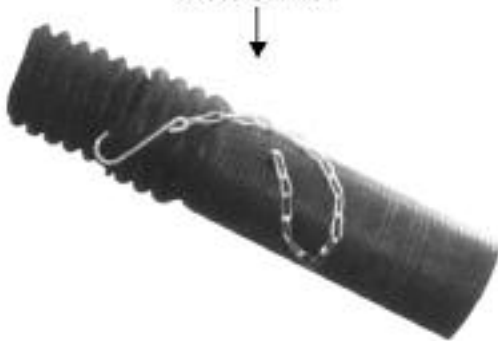

SIZE	PART NUMBER
3'	RAD300
4'	RAD400
5'	RAD500
6'	RAD600

O.E. STYLE TAIL PIPE HANGERS

WITH ARROWHEAD

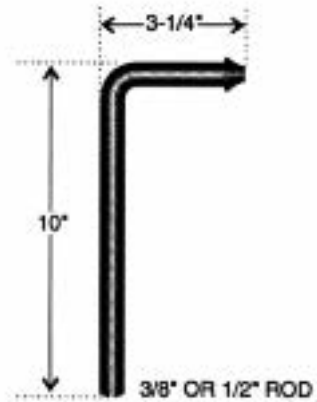

PART #: BRACK38 (3/8")
BRACK12 (1/2")

LIGHT DUTY VEHICLES



Nationwide toll free 1-866-229-3402

Fax 519-455-1103 • website: www.unitedmuffler.com

LIGHT DUTY PERFORMANCE SYSTEMS

FORD POWERSTROKE DIESEL 1999-UP

HEAVY DUTY ALUMINIZED - O.E. FIT MUFFLER

FEATURES:

- 4" HI-FLOW SYSTEM
- HEAVY DUTY ALUMINIZED MUFFLER
- 4" ALUMINIZED TAIL PIPES
- OPTIONAL 4" IN & 5" OUT MUFFLER AVAILABLE
- OPTIONAL 5" TAILPIPE AVAILABLE

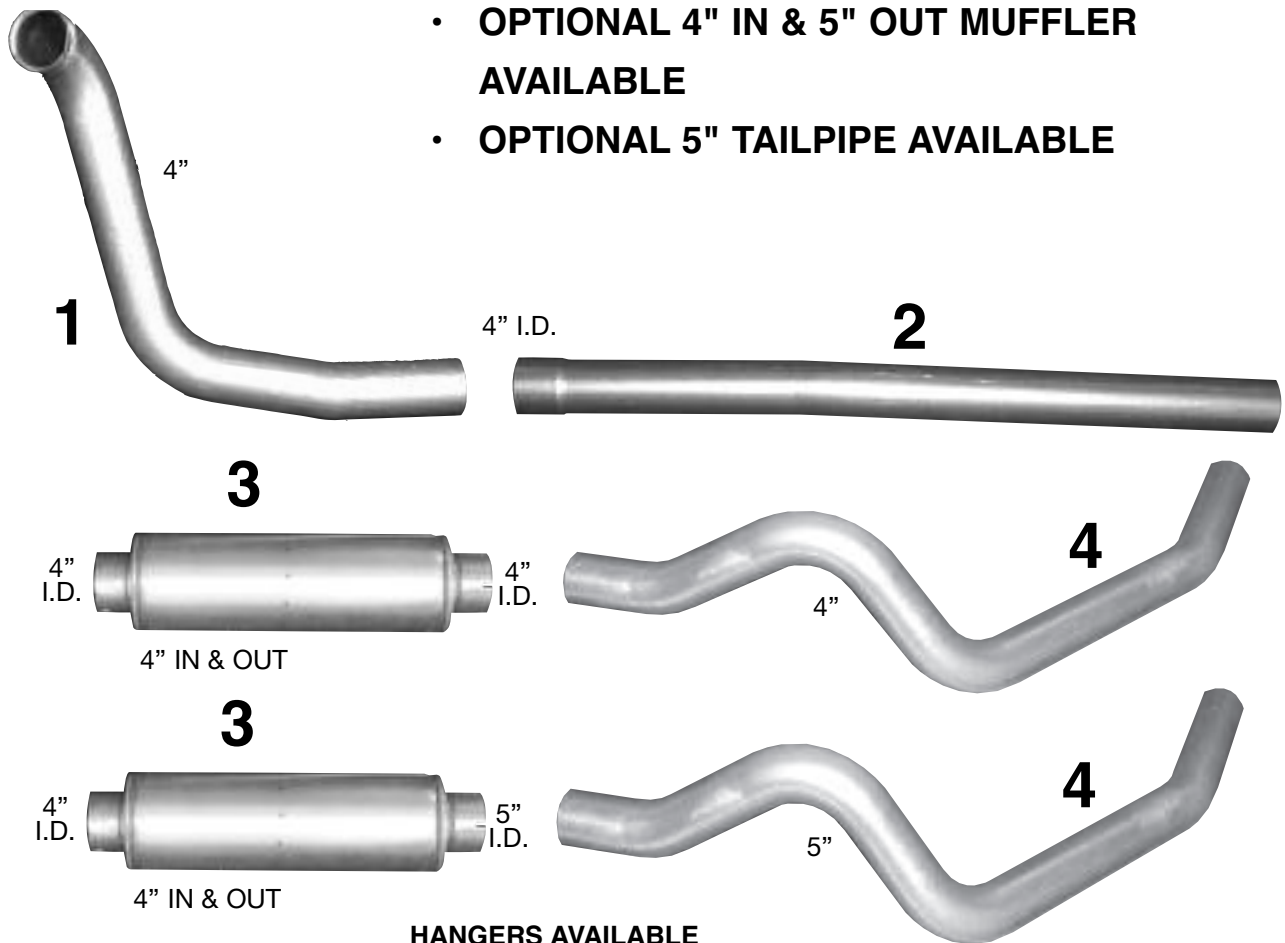

HANGERS AVAILABLE

1 - TURBO PIPE	2 - EXTENSION PIPE	3 - MUFFLER	4 - TAILPIPE
FORD400TURBO	FORD400EXTID/OD	7-0045	FLD400TP99 4"
SAME	SAME	CUS-101-02	FLD500TP99 5"

UNITED MUFFLER CORP.

U.S. toll free 1-800-247-5391 • Fax 515-224-0727 • website: www.auto-jet.com
 Canada toll free 1-866-229-3402 • Fax 519-455-1103 • website: www.unitedmuffler.com

LD 1

DIESEL DODGE RAM PICK-UP

1994-2001 RAM 2500/3500 5.9L CUMMINS TURBO DIESEL

PERFORMANCE SYSTEM

- ALL 4" ALUMINIZED TUBE IN BACK OF TURBO
- HEAVY DUTY-ALLWELDED-FREE FLOW MUFFLER

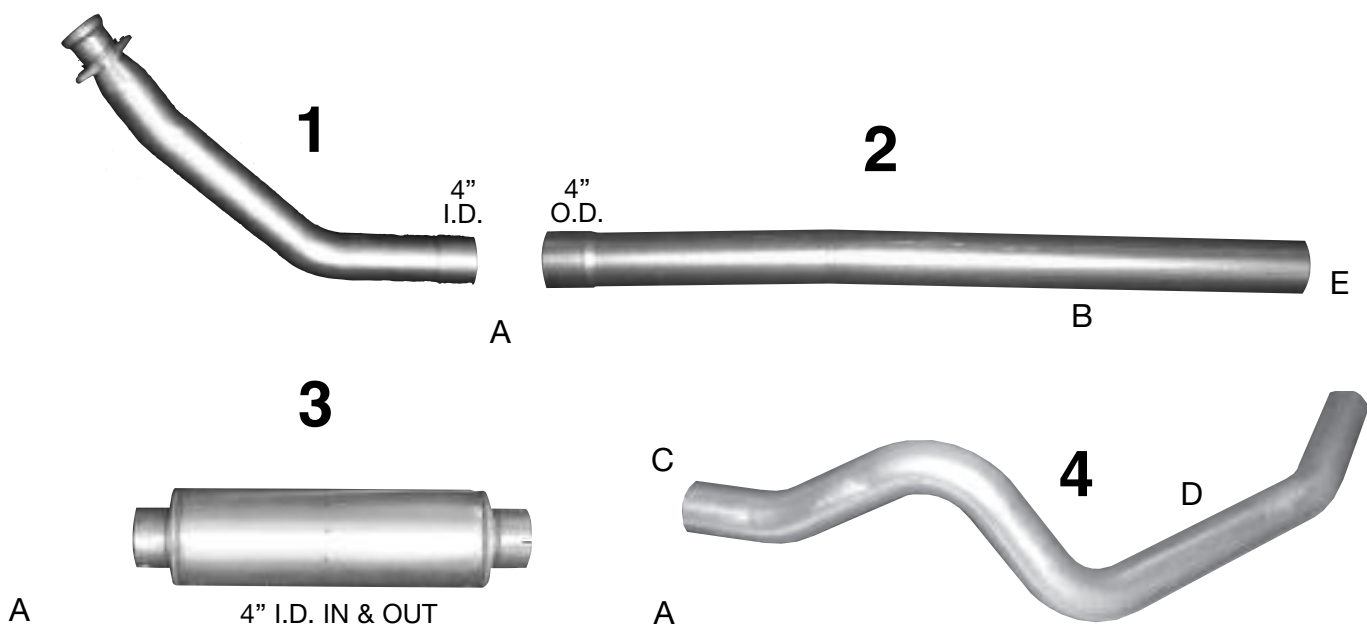

DESCRIPTION	1 - TURBO PIPE	2 - EXTENSION PIPE	3 - MUFFLER	4 - TAILPIPE
PART #	DODTURBO	DODPEXT	7-0045	DODPTP

ACCESSORIES



DESCRIPTION	A 4" Satinless Steel Clamp	E Turndown
PART #	400SCPF	OPTIONAL SEE PAGE ACC7

UNITED MUFFLER CORP.

U.S. toll free 1-800-247-5391 • Fax 515-224-0727 • website: www.auto-jet.com
 Canada toll free 1-866-229-3402 • Fax 519-455-1103 • website: www.unitedmuffler.com

DIESEL HI-FLOW PICK-UP SYSTEMS

1993-UP DODGE CUMMINS DIESEL PICK-UPS WITH CONVERTER

AUTO-JET SPECIAL 3" ALUMINIZED TAILPIPE

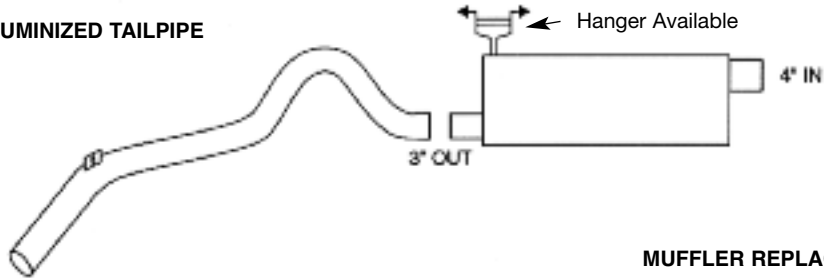

MUFFLER REPLACEMENT PIPE # DODMRPOE

	TAILPIPE (ALUMINIZED)	MUFFLER
1993-1996	54912	10-0045
1997-UP	54912	85-0050

CHEVROLET/GMC 6.5 LITRE DIESEL TURBO PIPE



AUTO-JET PART NO.: GM65T
 APPLICATION: 1992-1994 MODELS WITH
 FACTORY TURBO OPTION

CAN BE MODIFIED FOR LATER MODELS

UNITED MUFFLER CORP.

U.S. toll free 1-800-247-5391 • Fax 515-224-0727 • website: www.auto-jet.com
 Canada toll free 1-866-229-3402 • Fax 519-455-1103 • website: www.unitedmuffler.com

LIGHT DUTY ACCESSORIES

TURN DOWNS



CHROME OR 304 POLISHABLE STAINLESS STEEL

SIZE - I.D.	3"	3-1/2"	4"	5" - 18" LONG
CHROME PART #	TD300C	TD350C	TD400C	TD500C
304 POLISHABLE STAINLESS PART #	TD300304	TD350304	TD400304	TD500304

STAINLESS STEEL SLASH-CUT TIPS



304 POLISHABLE STAINLESS STEEL

SIZE - I.D.	2-1/2"	3"	3-1/2"	4"
PART #	250TIPSS	300TIPSS	350TIPSS	400TIPSS

ACCESSORIES

STAINLESS STEEL CLAMPS



U-BOLTS



DESCRIPTION	SIZE	SEAL CLAMPS	U-BOLTS
PART #	3"	300SCPF	U-300
PART #	3-1/2"	350SCPF	U-350
PART #	4"	400SCPF	U-400

UNITED MUFFLER CORP.

U.S. toll free 1-800-247-5391 • Fax 515-224-0727 • website: www.auto-jet.com
 Canada toll free 1-866-229-3402 • Fax 519-455-1103 • website: www.unitedmuffler.com



NEW SPECIAL MUFFLERS

HEAVY-DUTY ALUMINIZED MUFFLERS FOR PICK-UPS & VANS

FORD DIESEL "POWERSTROKE"

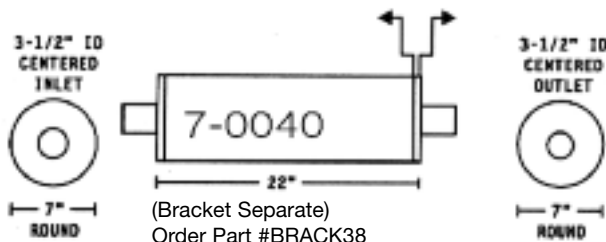

(Bracket Separate)
Order Part #BRACK38

**1994-1998 FORD POWERSTROKE
O.E. REPLACEMENT MUFFLER**

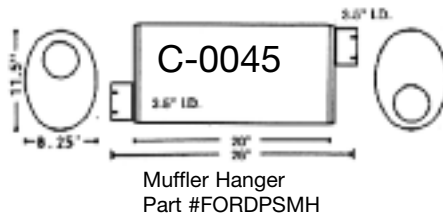

Muffler Hanger
Part #FORDPSMH

**1999 & UP FORD POWERSTROKE
O.E. REPLACEMENT MUFFLER**

DODGE DIESEL

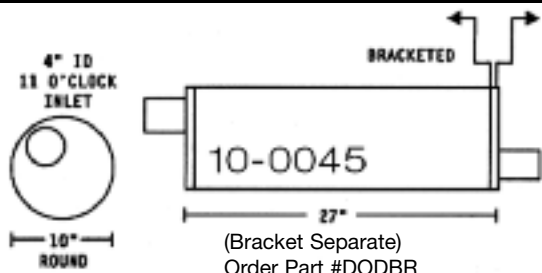

(Bracket Separate)
Order Part #DODBR

**O.E. REPLACEMENT MUFFLER FOR
1994-1996 DODGE DIESEL PICK-UP**

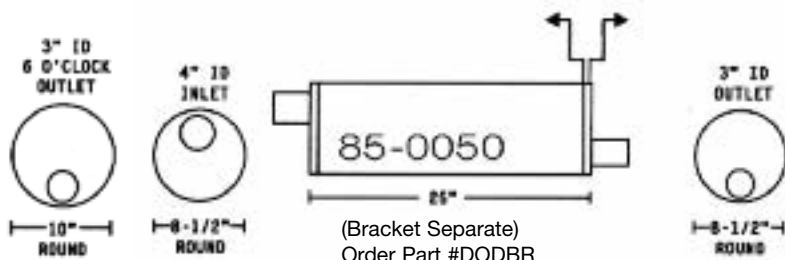

(Bracket Separate)
Order Part #DODBR

**O.E. REPLACEMENT MUFFLER FOR
1997 & UP DODGE DIESEL PICK-UP**

CHEVROLET - G.M.C.

APPLICATION:
G-30 VAN
ENGINE:
6.5 LITRE DIESEL
YEAR:
1998-UP
PART NO.:
65G300FL

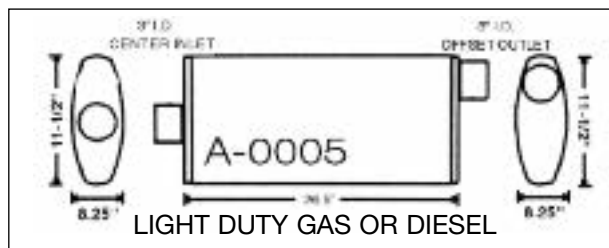

LIGHT DUTY GAS OR DIESEL

APPLICATION:
P-30 VAN
ENGINE:
350 C.I.
YEAR:
1996-UP
PART NO.:
C-0100

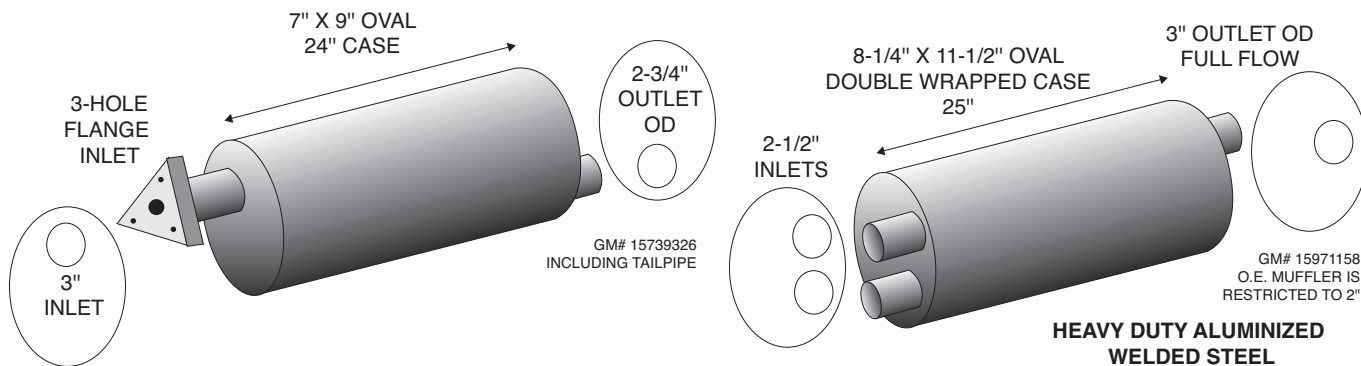

GM# 15739326
INCLUDING TAILPIPE

GM# 15971158
O.E. MUFFLER IS
RESTRICTED TO 2"

**HEAVY DUTY ALUMINIZED
WELDED STEEL**

UNITED MUFFLER CORP.

U.S. toll free 1-800-247-5391 • Fax 515-224-0727 • website: www.auto-jet.com
Canada toll free 1-866-229-3402 • Fax 519-455-1103 • website: www.unitedmuffler.com

LIGHT DUTY PERFORMANCE SYSTEMS

2004-06 FORD 6.0L POWER STROKE DIESEL

KIT # FP60



1



2



3



4



5

1-TURBO PIPE	2-TURBO EXTENSION	3-EXTENSION PIPE	4-MUFFLER	5-TAILPIPE
FORD60T	FORD60TEXT	FORD400EXT	7-0045	FLD400TP99

2001-04 6.6L CHEVY DUROMAX

KIT # CV604



1



2



3



4



5

1-TURBO	2-TURBO EXTENSION	3-EXTENSION	4-MUFFLER	5-TAILPIPE
CD66TURBO	CDTEXT	CDXTP	7~0075	CDTP04

UNITED MUFFLER CORP.

U.S. toll free 1-800-247-5391 • Fax 515-224-0727 • website: www.auto-jet.com
 Canada toll free 1-866-229-3402 • Fax 519-455-1103 • website: www.unitedmuffler.com

LIGHT DUTY PERFORMANCE SYSTEMS

2004-1/2 TO 2006 DODGE 5.9L H/O 2500/3500 5" SYSTEM

KIT # DO5906



1



2



3



4



5



6

1-TURBO PIPE	2-EXTENSION PIPE	3-REDUCER	4-REDUCER	5-MUFFLER	6-TAILPIPE
DCDTURBO5	DODEXT5	DODR4	DODR5	85-0037	DODTP5

UNITED MUFFLER CORP.

U.S. toll free 1-800-247-5391 • Fax 515-224-0727 • website: www.auto-jet.com
Canada toll free 1-866-229-3402 • Fax 519-455-1103 • website: www.unitedmuffler.com

LD 7

STERLING/ FORD EXHAUST SYSTEMS



Nationwide toll free 1-866-229-3402

Fax 519-455-1103 • website: www.unitedmuffler.com

STERLING 1998-UP EXHAUST PARTS

300 CUMMINS TURBO PIPE

PART NO.: STER300T
O.E. # F8HT5246NA

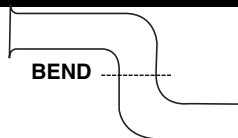

VERTICAL MUFFLER

PART NO.: V10-0010

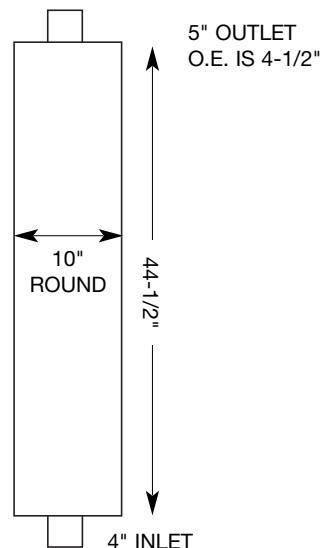

HORIZONTAL MUFFLERS

PART NO.: 11-0045

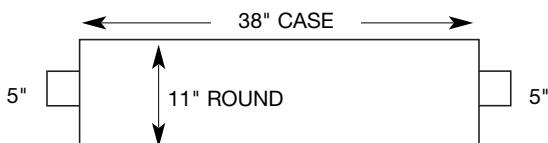

PART NO.: 11-0050
O.E. # 04-20629-001

NOTE: OUTLET REQUIRES 5" 32° ELBOW PART#50032E
REPLACES O.E.#F6HZ5255AAA

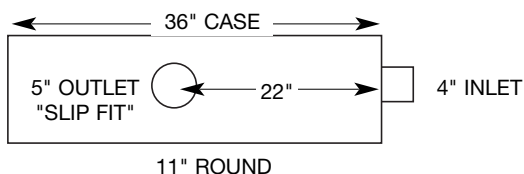

STERLING 1998-UP 3126 CATERPILLAR

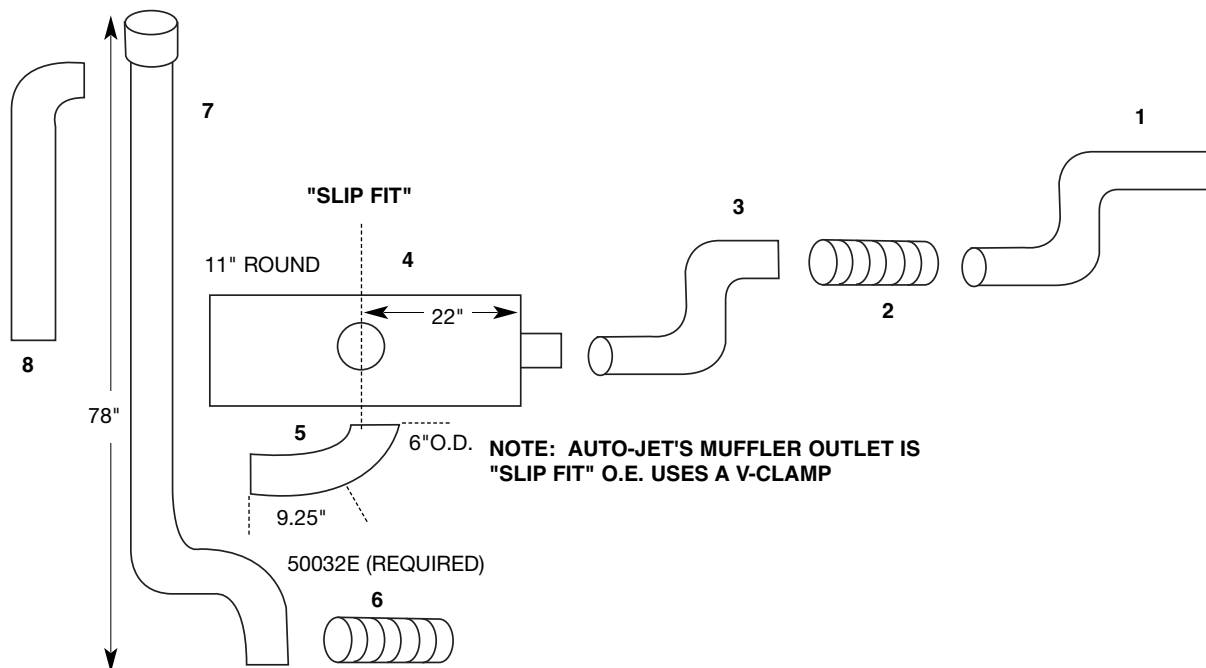

1 - TURBO PIPE	2 - FLEX	3 - FLEX TO MUFFLER PIPE	4 - MUFFLER	5 - MUFFLER OUTLET PIPE	6 - FLEX	7 - STACK	8 - STACK EXTENSION
STER3126T	FLEX40012	STERFMMD	11-0050	FORD50032E	FLEX50024	FDSTAK510	STAK485
O.E.# XC455246BA	--	F6HZ5A212FA	04-20629-001	F6HZ5255AAA	--	F7HZ5255AAA	5" O.D. 48" LONG W/ TURNOUT

UNITED MUFFLER CORP.

U.S. toll free 1-800-247-5391 • Fax 515-224-0727 • website: www.auto-jet.com
Canada toll free 1-866-229-3402 • Fax 519-455-1103 • website: www.unitedmuffler.com

FORD 1

FORD 1996-UP EXHAUST PARTS

1996-UP FORD FD-1060 CUMMINS B-SERIES DIESEL

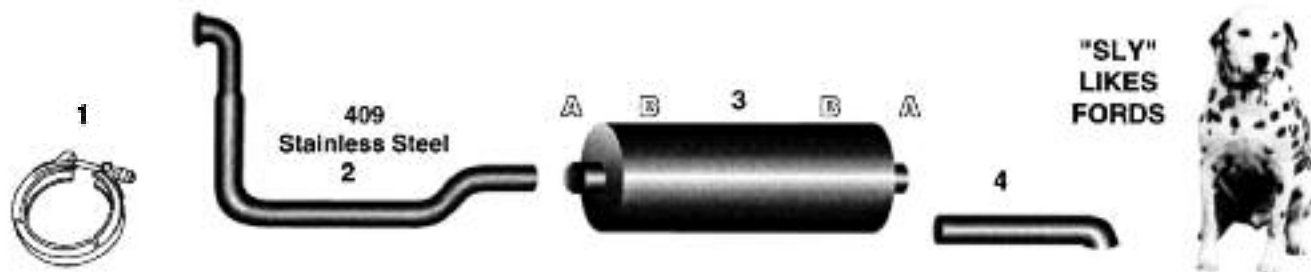

DESCRIPTION	1 V-CLAMP	2 TURBO PIPE	3-MUFFLER		4
			CATALYTIC	NON-CATALYTIC	TURN DOWN
PART #	FDVCL96	FDI060T96S (STAINLESS) FD1060T96A(ALUMINIZED)	400FDCAT	11-0025	TD400

1996-UP FORD FD-1060 CUMMINS B-SERIES DIESEL WITH STACK

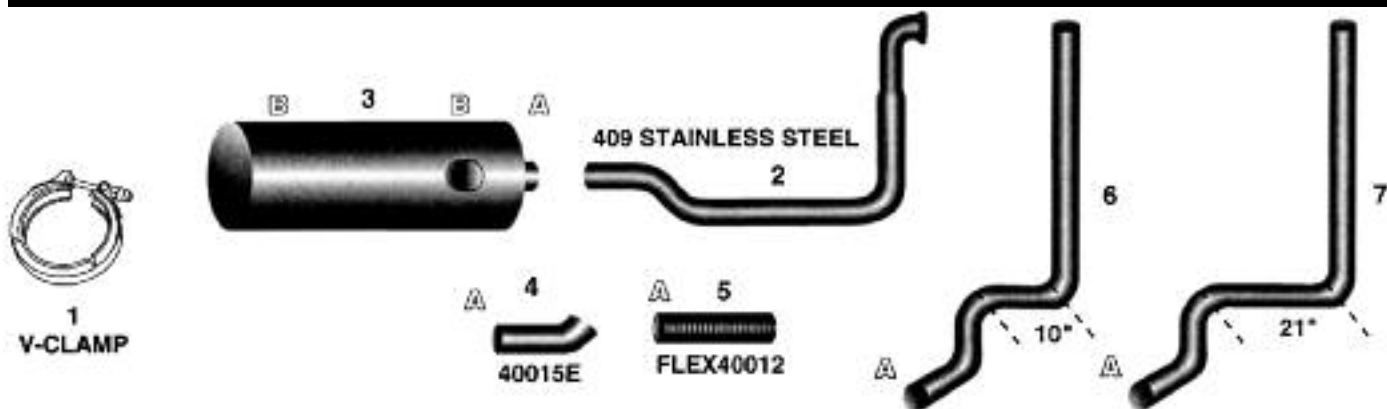

DESCRIPTION	1 V-CLAMP	2 TURBO PIPE	3-MUFFLER NON-CATALYTIC	4-FLEX MUFFLER OUTLET	5 FLEX	STACK PIPE	
						6	OR 7
PART #	FDVCL96	FDI060T96S (STAINLESS) FD1060T96A(ALUMINIZED)	11-0035	40015E	FLEX40012	FDSTAK410	FDSTACK421

ACCESSORIES



DESCRIPTION	CLAMPS		MUFFLER HANGERS
	A	B	
PART #	400SCPF	U-400	1100MH

UNITED MUFFLER CORP.

U.S. toll free 1-800-247-5391 • Fax 515-224-0727 • website: www.auto-jet.com
 Canada toll free 1-866-229-3402 • Fax 519-455-1103 • website: www.unitedmuffler.com

FORD EXHAUST SYSTEMS

1993-UP C-F-L-SERIES FD-1460 CUMMINS DIESEL

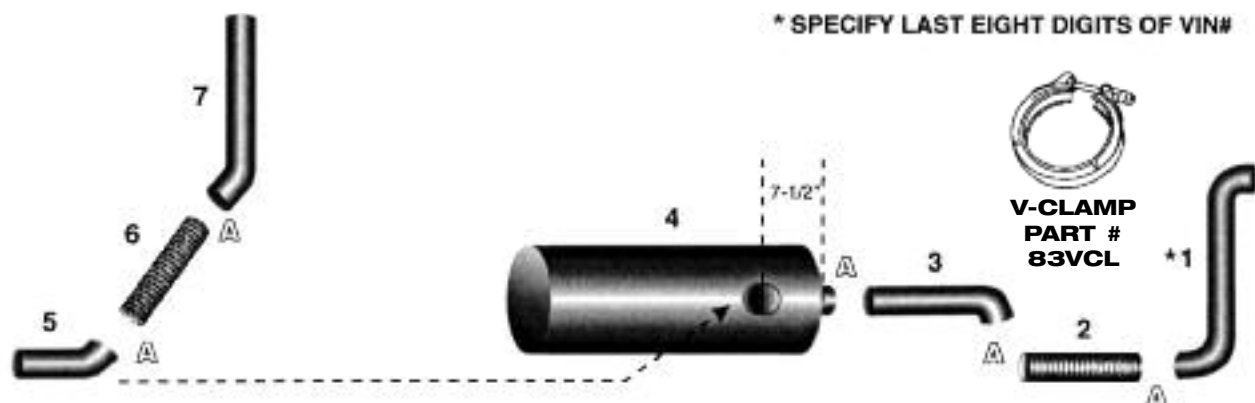

DESCRIPTION	1 TURBO-PIPE	2 FLEX	3 ELBOW	4-MUFFLER NON-CATALYTIC	5 ELBOW	6 FLEX	7 STACK
PART #	FD1460TA*	FLEX40012	4003OE	11-0035	40045E	FLEX40024	STAK48445

See accessories on top of page FORD 3.

1993-UP FORD FD-1460 CUMMINS C-F-L-SERIES DIESEL WITH CATALYTIC MUFFLER

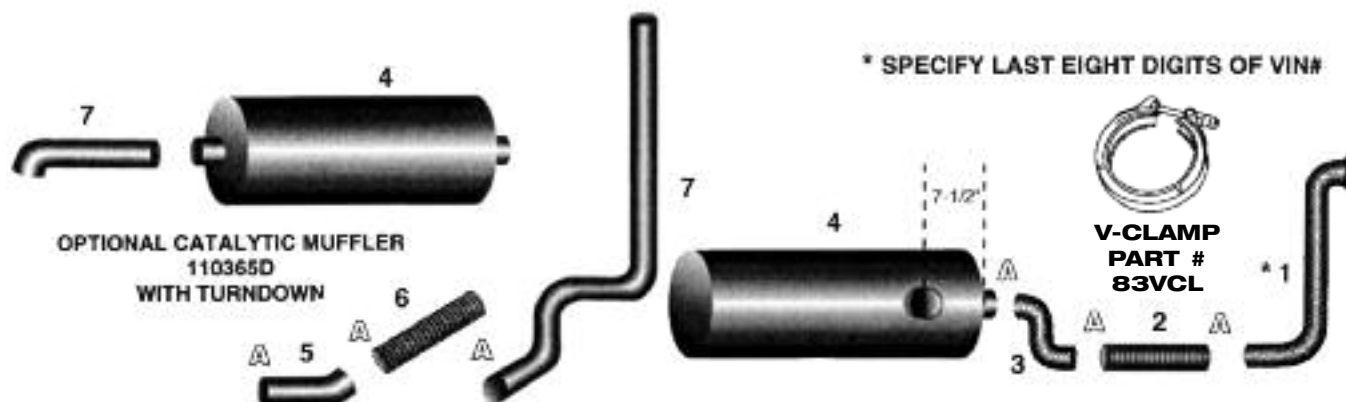

DESCRIPTION	1 TURBO PIPE	2 FLEX	3 - OFFSET PIPE	4 - MUFFLER		5 ELBOW	6 FLEX	7 - STACK/ TURNDOWN
				CATALYTIC	NON-CATALYTIC			
SYSTEMS WITH PASS. SIDE STACK	FD1460TSS	FLEX40012	FORDEXT964	N/A	11-0035	40015E	FLEX40018	FDSTAK410
NO STACK - USES TURNDOWN	FD1460TSS	FLEX40012	FORDEXT964	400FDCATC	11-0025	—	—	TD400

See accessories on top of page FORD 3.

UNITED MUFFLER CORP.

U.S. toll free 1-800-247-5391 • Fax 515-224-0727 • website: www.auto-jet.com
 Canada toll free 1-866-229-3402 • Fax 519-455-1103 • website: www.unitedmuffler.com

FORD EXHAUST SYSTEMS

ACCESSORIES



DESCRIPTION	CLAMPS A		MUFFLER HANGERS B
	PART #	400SCPF	U-400

1992-1995 FD-1060 CUMMINS DIESEL 6 BT 5.9 LITRE

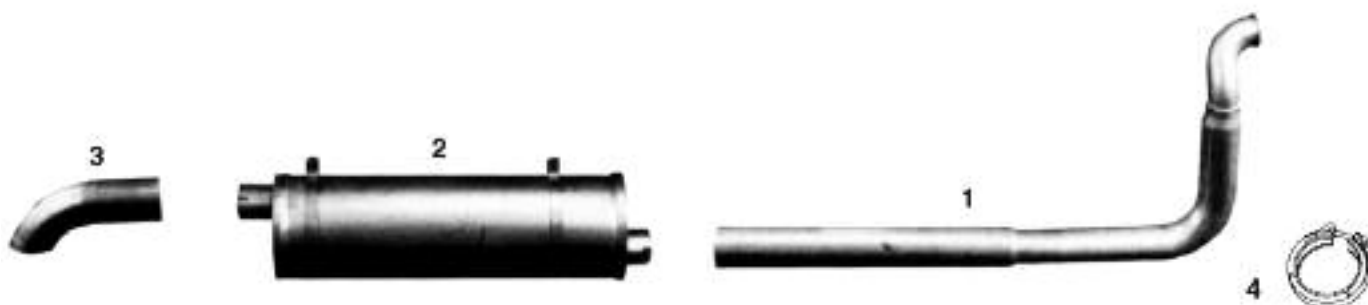

1 - TURBO PIPE	2 - MUFFLER	3 - TURN DOWN	4 - V-CLAMP
FD1060T	400FDA	TD400	TCVCL

Auto-Jet continuously updates its pattern inventory.

If you need exhaust parts not shown here, give us the O.E. # or send us the old part.

UNITED MUFFLER CORP.

U.S. toll free 1-800-247-5391 • Fax 515-224-0727 • website: www.auto-jet.com
 Canada toll free 1-866-229-3402 • Fax 519-455-1103 • website: www.unitedmuffler.com

FORD 4

FORD 600-900 SERIES TRUCKS 8.2 LITRE

1980-1990 MODELS WITH 8.2 LITRE ENGINE

8.2 LITRE NATURALLY ASPIRATED
ALUMINIZED

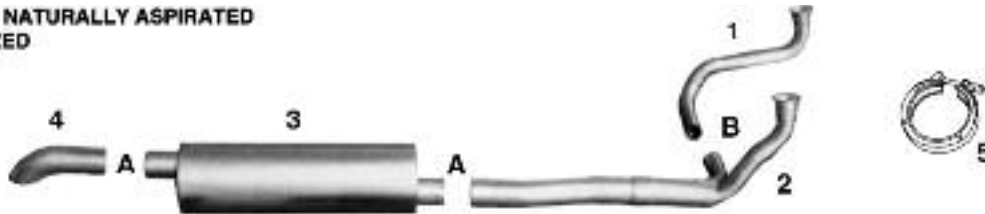

YEAR	1 - Y PIPE RIGHT	2 - CROSSOVER PIPE LEFT	3 - MUFFLER	4 - TURN DOWN	5 - V-CLAMP
1980 TO 1983	82FY	82FCO	C-0010 (OVAL)	TD400	82FVCLNA
1983 TO 1987	82FY83	82FCO	11-0005 (11" ROUND)	TD400	82FVCLNA

REVERSE SYSTEM WITH MUFFLER ON LEFT, DRIVER'S SIDE

8.2 LITRE NATURALLY ASPIRATED
ALUMINIZED



YEAR	1 - Y PIPE LEFT	2 - CROSSOVER PIPE RIGHT	3 - MUFFLER	4 - TURN DOWN	5 - V-CLAMP
1980 TO 1983	82FYL	82FCOL	C-0010 (OVAL)	TD400	82FVCLNA
1983 TO 1989	82FY83L	82FCOL	11-0005 (11" ROUND)	TD400	82FVCLNA

1980-1989 8.2 LITRE TURBO

ALUMINIZED



YEAR	1 - TURBO PIPE	2 - MUFFLER	3 - TURN DOWN	4 - V-CLAMP
1983 & UP	82FTURBO83	40082FTA (11" ROUND)	TD400	82FVCLT
1980 TO 1982	82FTURBO	C-0010 (OVAL)	TD400	82FVCLT

ACCESSORIES

MUFFLER HANGERS



FORD 11MH (ROUND)



FORD OVMH (OVAL)



CLAMPS

A(4")
400SCPF
U-400

B(2³/₄")
275SCPF
U-275

UNITED MUFFLER CORP.

U.S. toll free 1-800-247-5391 • Fax 515-224-0727 • website: www.auto-jet.com
Canada toll free 1-866-229-3402 • Fax 519-455-1103 • website: www.unitedmuffler.com

FORD 5

FORD 600-900 SERIES TRUCKS

1975-1989 MODELS WITH 3208 CATERPILLAR

NATURALLY ASPIRATED

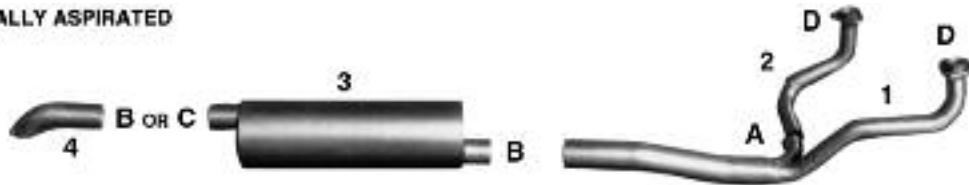

YEAR	1 - Y PIPE RIGHT	2 - CROSSOVER PIPE LEFT	3 - MUFFLER	4 - TAIL PIPE
1983 TO 1987	3208FY83	3208FCO83	11-0005	TD400
1979 TO 1982	3208FY79	3208FCO79	C-0055	TD350
1975 TO 1978	3208FY75	3208FCO75	C-0055	TD350

REVERSE SYSTEM WITH MUFFLER ON LEFT SIDE OF CHASSIS



3208 CAT NATURALLY ASPIRATED

YEAR	1 - Y PIPE LEFT	2 - CROSSOVER PIPE LEFT	3 - MUFFLER	4 - TURN DOWN
1983 TO 1987	3208FY83L	3208FCO83L	11-0005	TD400

1980-1989 L-SERIES

3208 CAT NATURALLY ASPIRATED

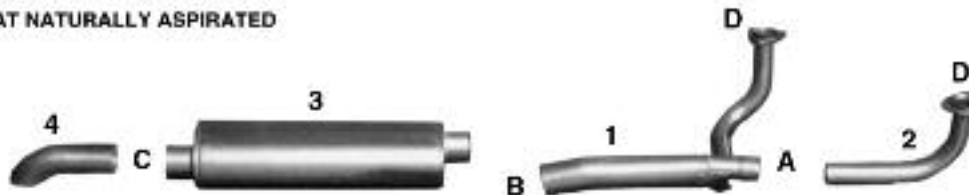

1980 TO 1989	1 - Y PIPE RIGHT	2 - CROSSOVER PIPE LEFT	3 - MUFFLER	4 - TURN DOWN
WITH CONSTRUCTION OPTION	3208FLYWC	3208FLCO	C-0010	TD400
WITHOUT CONSTRUCTION OPTION	3208FLYWOC (PICTURED)	3208FLCO	C-0010	TD400

ACCESSORIES

EXHAUST RING



3208ER

MUFFLER HANGERS



FORD 11MH (ROUND)



FORD OVMH (OVAL)



A(2³/₄"')

275SCPF

U-275

B(4"')

400SCPF

U-400

CLAMPS

C(4" 83 & UP)

400SCPF

U-400

C(3¹/₂" 75-82)

350SCPF

U-350

UNITED MUFFLER CORP.

U.S. toll free 1-800-247-5391 • Fax 515-224-0727 • website: www.auto-jet.com
 Canada toll free 1-866-229-3402 • Fax 519-455-1103 • website: www.unitedmuffler.com

FORD 6

FORD L-SERIES

1980-1986 L, LN, LNT, LT, LTS SERIES WITH CAT 3208N ENGINES

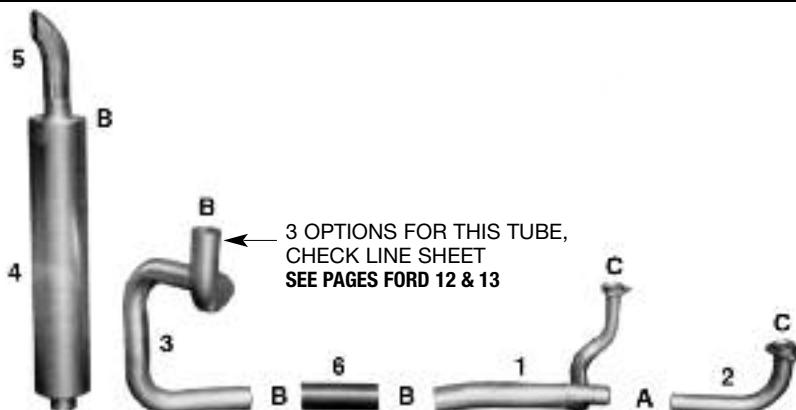

	1 - Y PIPE LEFT	2 - CROSSOVER PIPE RIGHT	3 - FLEX TO MUFFLER PIPE	4 - MUFFLER	5 - STACK	6 - FLEX
WITH CONSTRUCTION OPTION	3208FLYWC	3208FLCO	5A212B 5A212C 5A212F	V9-0010	STAK484	FLEX40012
WITHOUT CONSTRUCTION OPTION	3208FLYWOC	3208FLCO	5A212B 5A212C 5A212F	V9-0010	STAK484	FLEX40012

1982-1989 L, LN, LNT, LT, LTS SERIES WITH CAT 3208T ENGINES

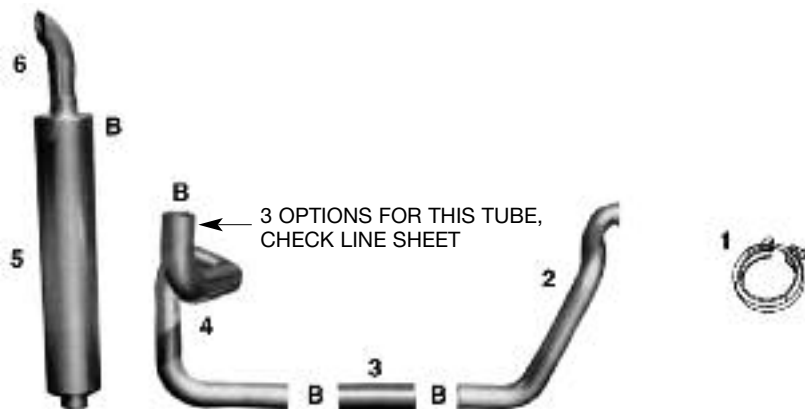

1 - V-CLAMP	2 - TURBO PIPE	3 - FLEX	4 - EXTENSION	5 - MUFFLER	6 - STACK
3208VCLT	AUTO TRANS: 46848G STD. TRANS: 46948G	FLEX40018	5A212B 5A212C 5A212F	B400400	STAK484

ACCESSORIES

EXHAUST RING

C



3208ER

See page ACC 7 for Muffler Guards and Clamp Kits.



CLAMPS

A(2³/₄"')

275SCPF

U-275

B(4"')

400SCPF

U-400

UNITED MUFFLER CORP.

U.S. toll free 1-800-247-5391 • Fax 515-224-0727 • website: www.auto-jet.com
 Canada toll free 1-866-229-3402 • Fax 519-455-1103 • website: www.unitedmuffler.com

FORD 7

FORD 600-900

1987-UP 6.6 & 7.8 LITRE DIESEL MUFLER RIGHT, F & L SERIES

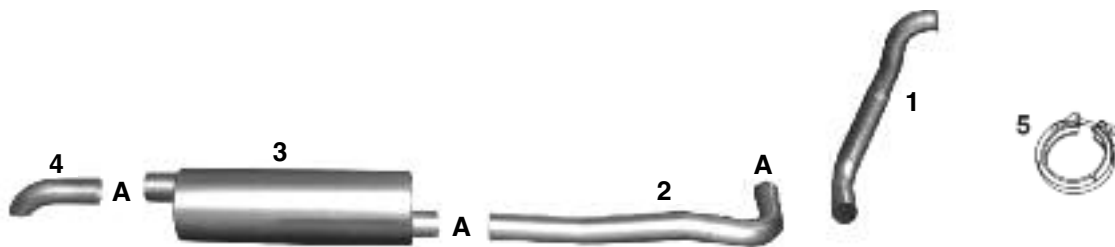

SIZE	1 - TURBO PIPE	2 -TURBO TO MUFLER	3 - MUFLER	4 - TURN DOWN	5 - V-CLAMP
6.6 LITRE	66FTURBO	F6TMP	11-0005	TD400	66FVCL
7.8 LITRE	78FTURBO	F6TMP L-SERIES - F6TMPL	11-0005	TD400	66FVCL

1987-UP 6.6 & 7.8 LITRE DIESEL MUFLER LEFT, F- SERIES

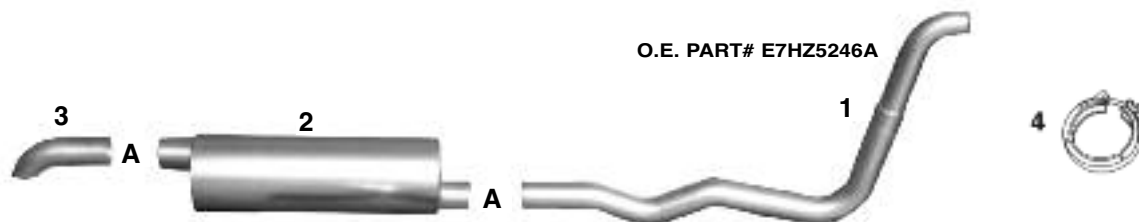

SIZE	1 - TURBO PIPE	2 - MUFLER	3 - TURN DOWN	4 - V-CLAMP
6.6-7.8 LITRE	66F81TURBO	11-0005	TD400	66FVCL

1987-UP 6.6 & 7.8 LITRE DIESEL C-SERIES CARGO

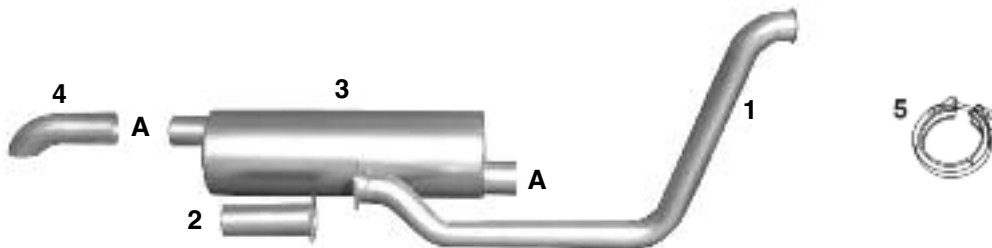

SIZE	1 - TURBO PIPE	2 -EXTENSION	3 - MUFLER	4 - TURN DOWN	5 - V-CLAMP
6.6 LITRE	66FCTURBO	66FCEXT	11-0005	TD400	66FVCL
7.8 LITRE	78FCTURBO	66FCEXT	11-0005	TD400	66FVCL

ACCESSORIES

MUFLER HANGER



FORD 11MH

CLAMPS



A(4")
400SCPF
U-400

UNITED MUFLER CORP.

U.S. toll free 1-800-247-5391 • Fax 515-224-0727 • website: www.auto-jet.com
Canada toll free 1-866-229-3402 • Fax 519-455-1103 • website: www.unitedmuffler.com

FORD 8

FORD 600-900 F & L SERIES

1988-UP 6.6 & 7.8 LITRE DIESEL WITH VERTICAL STACK

DIESEL

FOR RIGHT HAND STACK
SEE PAGE ACC 6

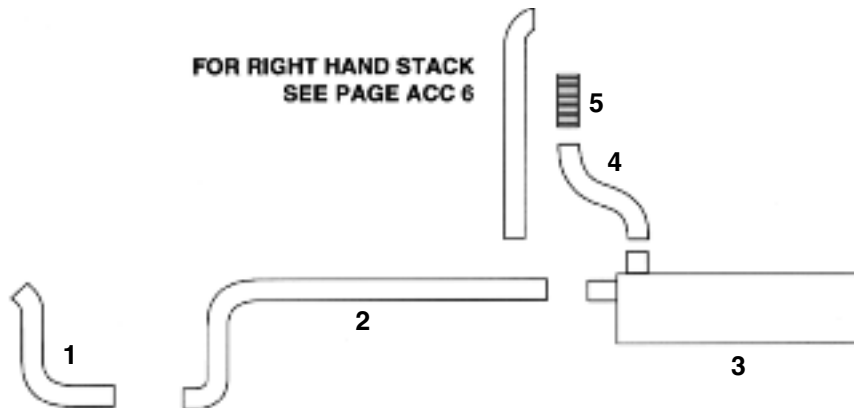

SIZE	1 - TURBO PIPE	2 -TURBO TO MUFFLER	3 - MUFFLER	4 - OUTLET PIPE	5 - FLEX
6.6 LITRE	66FTURBO	F6TMP	11-0010	F6MOPJ	FLEX40012
7.8 LITRE	78FTURBO	F6TMP L-SERIES - F6TMPL	11-0010	F6MOPJ	FLEX40012

UNITED MUFFLER CORP.

U.S. toll free 1-800-247-5391 • Fax 515-224-0727 • website: www.auto-jet.com
Canada toll free 1-866-229-3402 • Fax 519-455-1103 • website: www.unitedmuffler.com

FORD 9

FORD F & L SERIES

1980-1992 370-429 C.I.D.

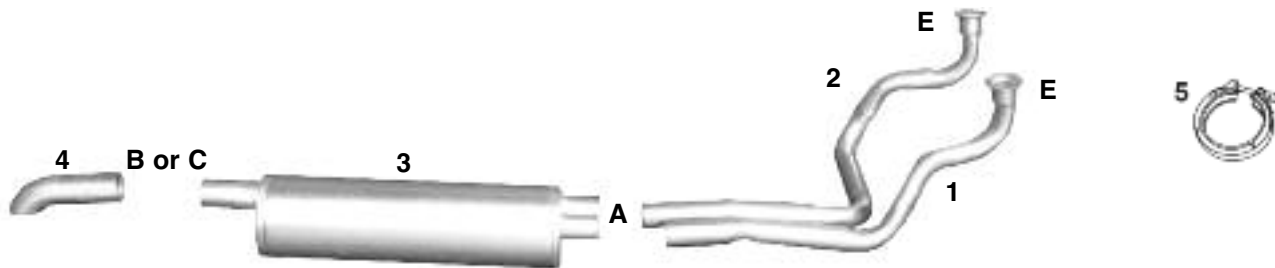

YEAR	1 - RIGHT MANIFOLD PIPE	2 -LEFT MANIFOLD PIPE	3 - MUFFLER	4 - TURN DOWN	5 - V-CLAMP
1989 TO 1993	370R89	370L89	85-0006	TD350	370VCL89
1985 TO 1988	370R85SS	370L85SS	85-0005	TD275	370VCLHD
1980 TO 1984	370R83	370L83	85-0005	TD275	370VCLHD
1980 TO 1988	370R80L	370L80L	85-0005	TD275	370VCLHD

F & L-SERIES MUFFLER ON LEFT SIDE OF CHASSIS

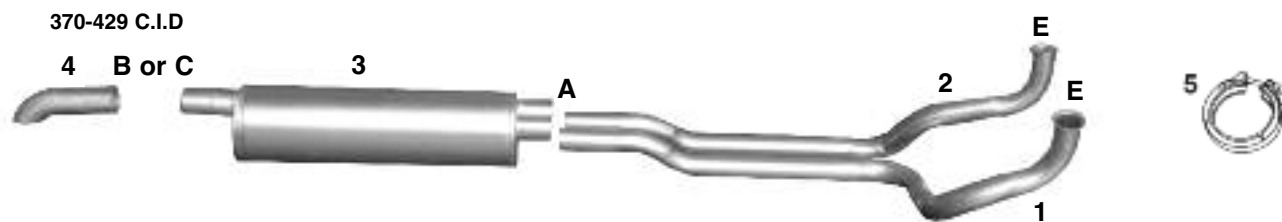

YEAR	1 - RIGHT MANIFOLD PIPE	2 -LEFT MANIFOLD PIPE	3 - MUFFLER	4 - TURN DOWN	5 - V-CLAMP
1989 & UP	370R89ML	370L89ML	85-0006	TD350	370VCL89
1980 TO 1988	370R83ML	370L83ML	85-0005	TD275	370VCLHD

ACCESSORIES



UNITED MUFFLER CORP.

U.S. toll free 1-800-247-5391 • Fax 515-224-0727 • website: www.auto-jet.com
 Canada toll free 1-866-229-3402 • Fax 519-455-1103 • website: www.unitedmuffler.com

FORD 10

FORD EXHAUST COMPONENTS

ACCESSORIES / REPLACEMENT PARTS

MANIFOLD

370-429 C.I. WITH AIR TUBE HOLES
PLUGS OR AIR TUBES IN STOCK
RIGHT OR LEFT HAS SAME PART #
OE # F2HZ9430OE



PART # 370MAN

EXTENSION PIPE

AUTO-JET PART NO.: F6MOPJ
Replaces Ford Part No. E7HZ5255D
Requires FLEX40012 on outlet end to replace O.E.

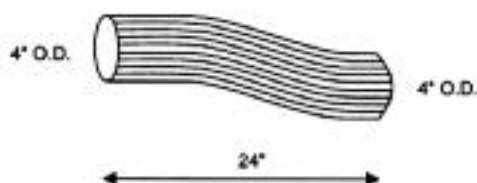

CONVERTERS

1987-1995 FORD PICK-UP & VAN,
351 C.I. & 460 C.I., WITH 4-BOLT FLANGE

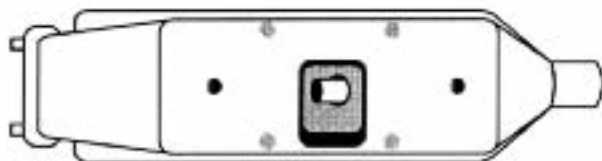

PART # CONVBM1 - 1 Air Tube

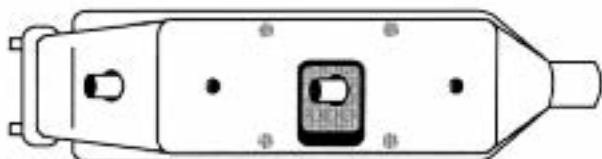

PART # CONVBM2 - 2 Air Tube

CONVERTERS

1996-UP FORD, 351 C.I. & 460 C.I., 3" SLIPFIT

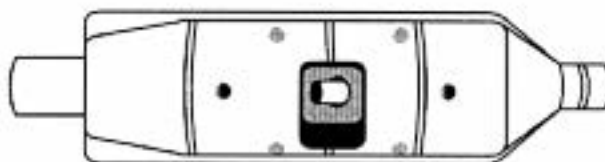

PART # CONVFORD31 - 1 Air Tube

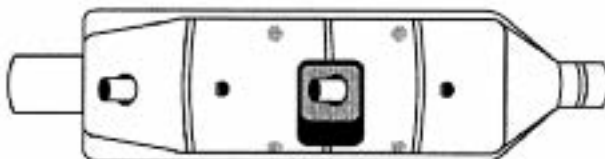

PART # CONVFORD32 - 2 Air Tube

UNITED MUFFLER CORP.

U.S. toll free 1-800-247-5391 • Fax 515-224-0727 • website: www.auto-jet.com
Canada toll free 1-866-229-3402 • Fax 519-455-1103 • website: www.unitedmuffler.com

FORD EXHAUST COMPONENTS

ACCESSORIES / REPLACEMENT PARTS

EXHAUST PIPE

AUTO-JET PART NO.: 5A212C

Replaces Ford Part No. E2HZ5A212C

Caterpillar 3208T Engines LN-LNT 8000 Series
Nelson 90989A

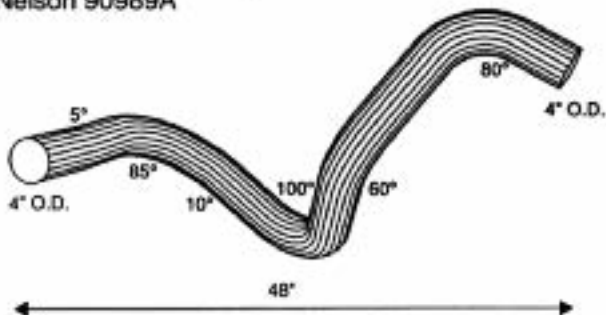

EXHAUST PIPE

AUTO-JET PART NO.: 5A212F

Replaces Ford Part No. E2HZ5A212F

Caterpillar 3208T Engines L-LT-LTS 8000 Series
Nelson 90990

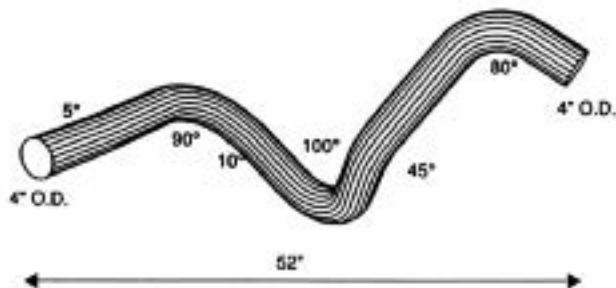

FORD STACKS

FOR TRUCKS WITH HORIZONTAL MUFFLERS
INCLUDING STATE HIGHWAY DEPARTMENT TRUCKS.

4" - FDSTAK410
5" - FDSTAK510

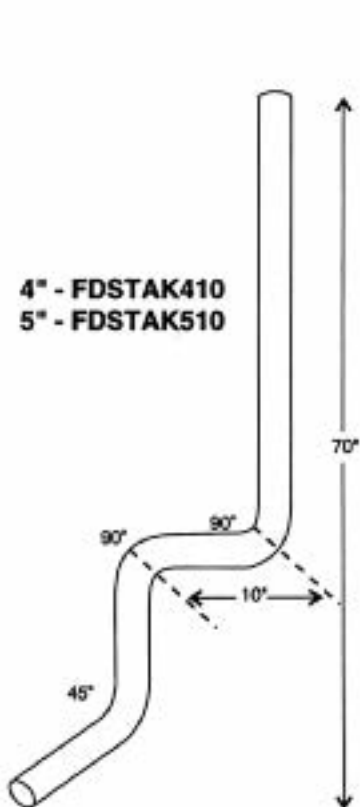

4" - FDSTAK421
5" - FDSTAK521

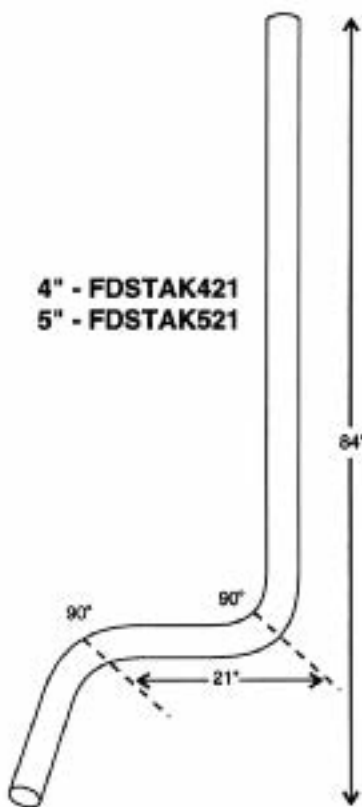

FDSTAKDOT1

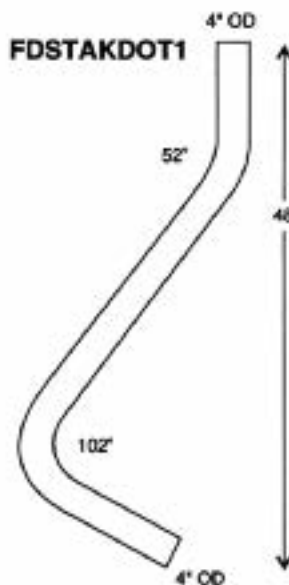

FDSTAKDOT2



UNITED MUFFLER CORP.

U.S. toll free 1-800-247-5391 • Fax 515-224-0727 • website: www.auto-jet.com
Canada toll free 1-866-229-3402 • Fax 519-455-1103 • website: www.unitedmuffler.com

FORD EXHAUST COMPONENTS

ACCESSORIES / REPLACEMENT PARTS

AUTO-JET PART NO.: 99290L

Replaces Ford Part No. E0HZ5A212F
Cummins NTC Engines LN-LNT 9000 Series

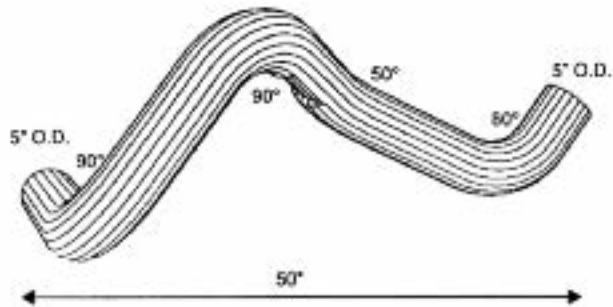

EXTENSION

AUTO-JET PART NO.: 92190L

Replaces Ford Part No. E2HZ5A212B
Cummins NTC Engines LTL 9000 Series
After 10/05/81

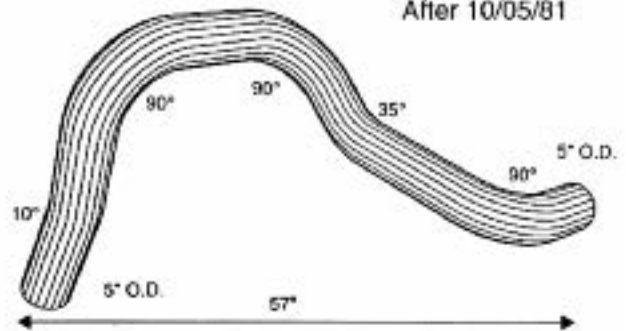

EXTENSION

AUTO-JET PART NO.: 5A212B

Replaces Ford Part No. E0HZ5A212B
Caterpillar 3208N Engines L-LT-LTS 8000 Series

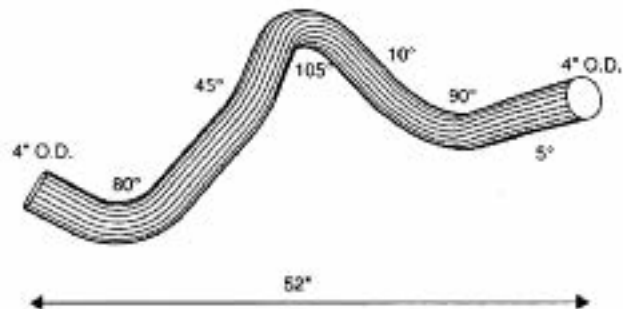

INLET PIPE

AUTO-JET PART NO.: 46848G - AUTOMATIC TRANSMISSION E2HZ5246D
46948G - STANDARD TRANSMISSION E2HZ5246E

Caterpillar 3208T Engines L-LN-LNT-LT-LTS 8000 Series

3208VCLT

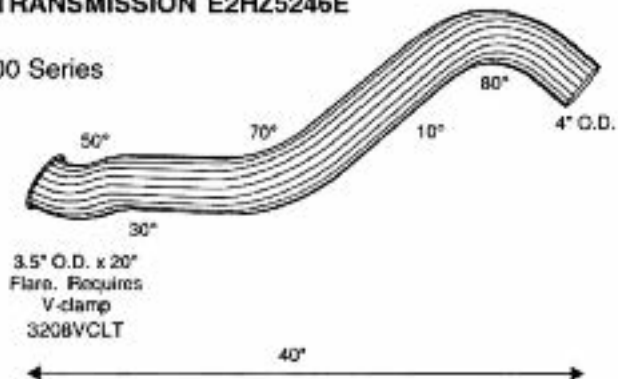

UNITED MUFFLER CORP.

U.S. toll free 1-800-247-5391 • Fax 515-224-0727 • website: www.auto-jet.com
Canada toll free 1-866-229-3402 • Fax 519-455-1103 • website: www.unitedmuffler.com

FORD 13

FORD MUFFLERS



MEDIUM DUTY, END INLET - END OUTLET

AUTO-JET PART NO.: 400FDA
APPLICATION: DIESEL TURBO
ENGINE: FD-1060 CUMMINS
YEAR: 1992 & UP

4" OUTLET - OFFSET

11"
ROUND

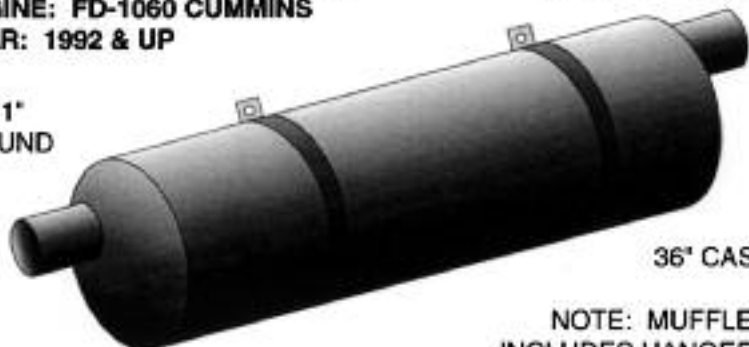

36" CASE

NOTE: MUFFLER
INCLUDES HANGERS

4" INLET - OFFSET

MUFFLER HANGER

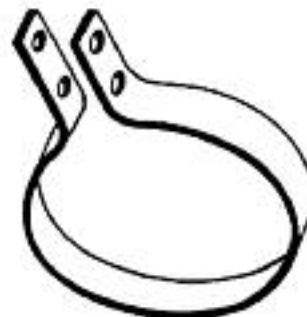

FOR HANGERS ONLY,
ORDER #1100MH

AUTO-JET PART NO.: 40082FTA
APPLICATION: DIESEL TURBO
ENGINE: 8.2 LITRE & 3208 CAT.
YEAR: 1983 TO 1988

4" OUTLET - OFFSET

11"
ROUND



30" CASE

4" INLET - OFFSET

MUFFLER HANGER



#FORD11MH

AUTO-JET PART NO.: 6-0025
APPLICATION: GAS
ENGINE: 330 - 361 - 389 - 391 C.I.
YEAR: 1978 & PRIOR

2-1/2" OUTLET - OFFSET

6"
ROUND



26-1/2" CASE

MUFFLER HANGER



UNITED MUFFLER CORP.

U.S. toll free 1-800-247-5391 • Fax 515-224-0727 • website: www.auto-jet.com
Canada toll free 1-866-229-3402 • Fax 519-455-1103 • website: www.unitedmuffler.com

FORD 14

AUTO-JET PART NO.: C-0010
APPLICATION: DIESEL
ENGINE: 8.2 LITRE & 3208 CAT.
YEAR: 1979 TO 1982

8-1/4 X 11-1/2"
 OVAL



4" INLET - OFFSET

4" OUTLET - OFFSET

26-1/2" CASE

MUFFLER HANGER
 OVAL



#FORDOVMH

AUTO-JET PART NO.: 11-0005
APPLICATION: DIESEL
ENGINE: 8.2 - 6.6 - 7.8 LITRES
YEAR: 1983 TO 1992

11"
 ROUND

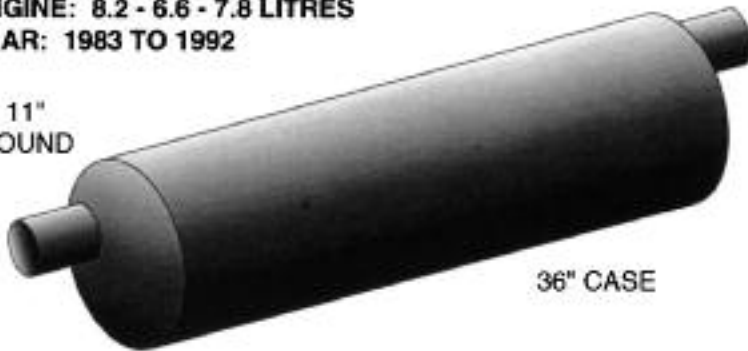

4" INLET - OFFSET

4" OUTLET - OFFSET

36" CASE

MUFFLER HANGER
 11" ROUND



#FORD11MH

AUTO-JET PART NO.: 85-0005 (2-3/4" OUTLET)
APPLICATION: GAS 370 C.I. & 429 C.I.
YEAR: 1979 TO 1991
AUTO-JET PART NO.: 2-250350 (3-1/2" OUTLET)
APPLICATION: SAME
YEAR: 1992 & UP

8-1/2"
 ROUND



2-1/2" DUAL INLETS

2-3/4" OR 3-1/2"
 OUTLET

30" CASE

MUFFLER HANGER

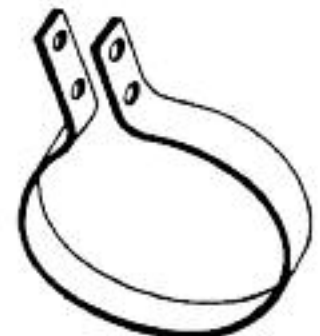

#850MH

UNITED MUFFLER CORP.

U.S. toll free 1-800-247-5391 • Fax 515-224-0727 • website: www.auto-jet.com
 Canada toll free 1-866-229-3402 • Fax 519-455-1103 • website: www.unitedmuffler.com

FORD 15

FORD MUFFLERS



CENTER INLET

AUTO-JET PART NO.: 11-0045
APPLICATION: FORD "STERLING"

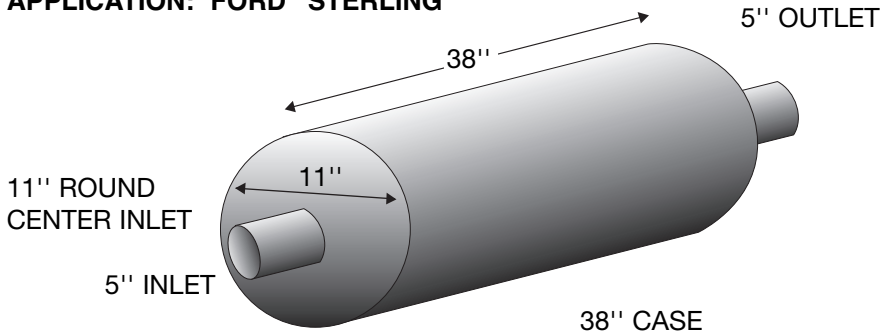

INLET END VIEW

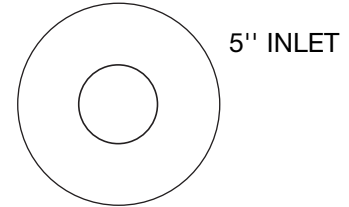

5" INLET
5" CENTER INLET & OUTLET
11" ROUND

AUTO-JET PART NO.: 400FDCAT
FORD PART NO.: F7HZ5F250Y
APPLICATION: B-SERIES CUMMINS DIESEL
CATALYTIC MUFFLER

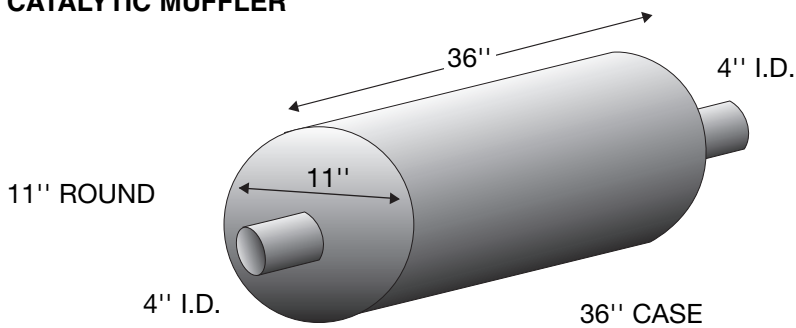

CATALYTIC MUFFLER

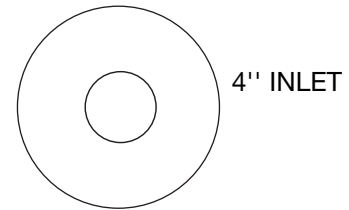

4" INLET
4" CENTER INLET & OUTLET
11" ROUND

AUTO-JET PART NO.: 400FDCATC
APPLICATION: C-SERIES CUMMINS DIESEL
CATALYTIC MUFFLER

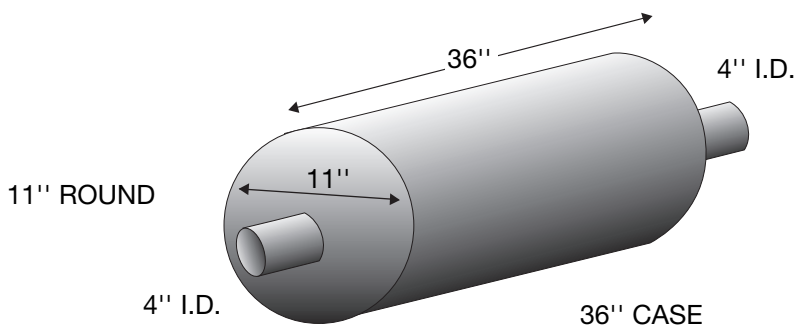

CATALYTIC MUFFLER

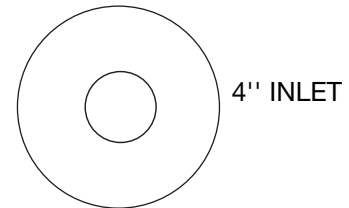

4" INLET
4" CENTER INLET & OUTLET
11" ROUND

UNITED MUFFLER CORP.

U.S. toll free 1-800-247-5391 • Fax 515-224-0727 • website: www.auto-jet.com
Canada toll free 1-866-229-3402 • Fax 519-455-1103 • website: www.unitedmuffler.com

FORD 16



FORD MUFFLERS

SIDE OUTLET

AUTO-JET PART NO.: CUS-133-01

10" X 15" OVAL
30" CASE

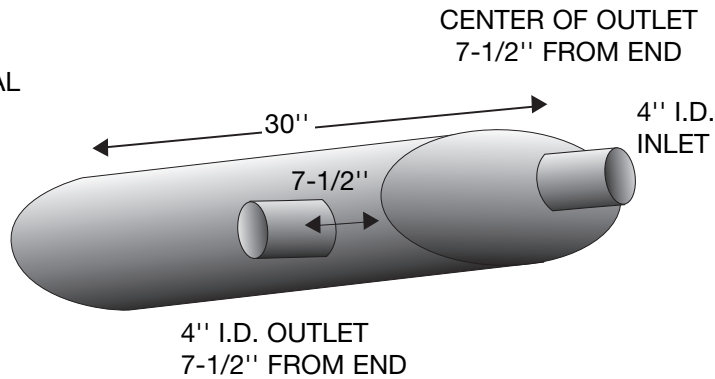

INLET END VIEW

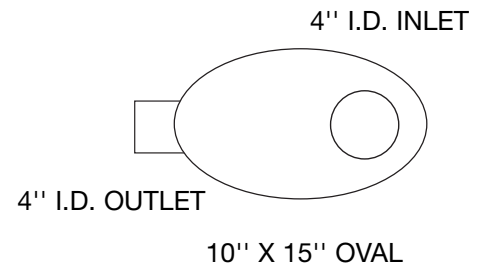

AUTO-JET PART NO.: 22086L
SIDE OUTLET

10" X 15" OVAL
36" CASE

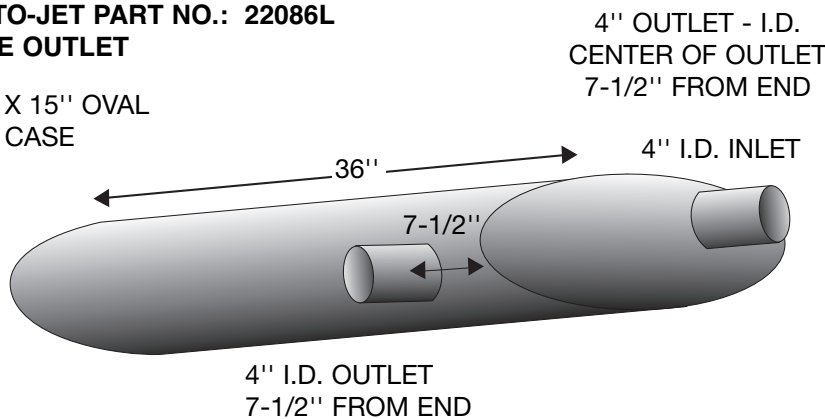

INLET END VIEW

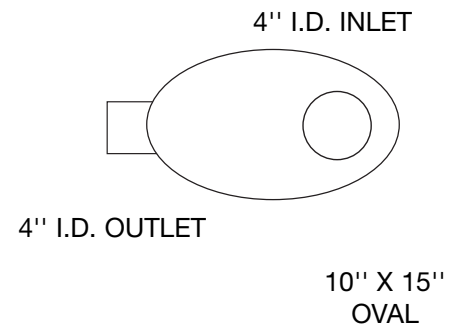

AUTO-JET PART NO.: 11-0010

11" ROUND
35" CASE

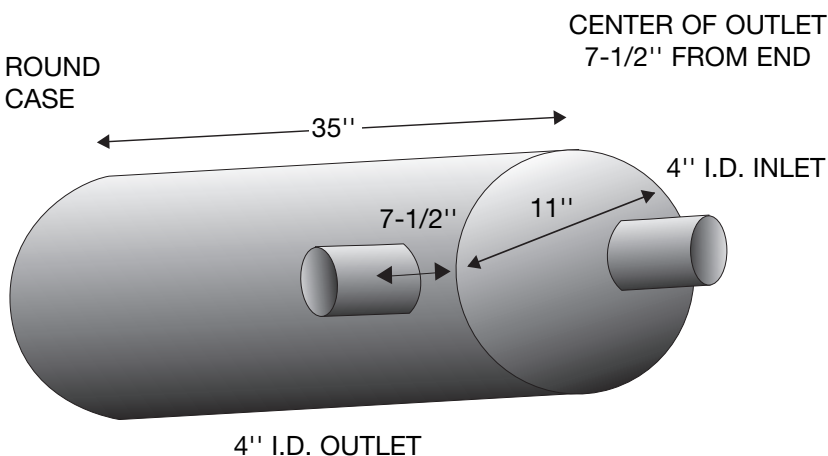

INLET END VIEW

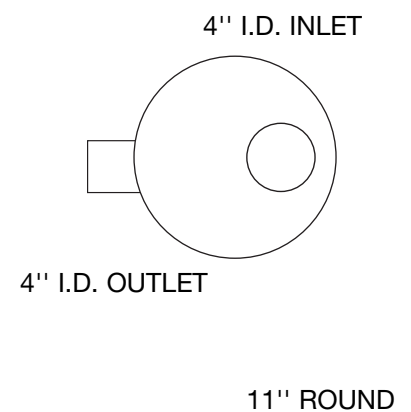

UNITED MUFFLER CORP.

U.S. toll free 1-800-247-5391 • Fax 515-224-0727 • website: www.auto-jet.com
Canada toll free 1-866-229-3402 • Fax 519-455-1103 • website: www.unitedmuffler.com

FORD 17

FORD MUFFLERS



SIDE OUTLET

**AUTO-JET PART NO.: 11-0010 HEAVY DUTY
53086L ECONOMY**

**CENTER OF OUTLET
7-1/2" FROM END**

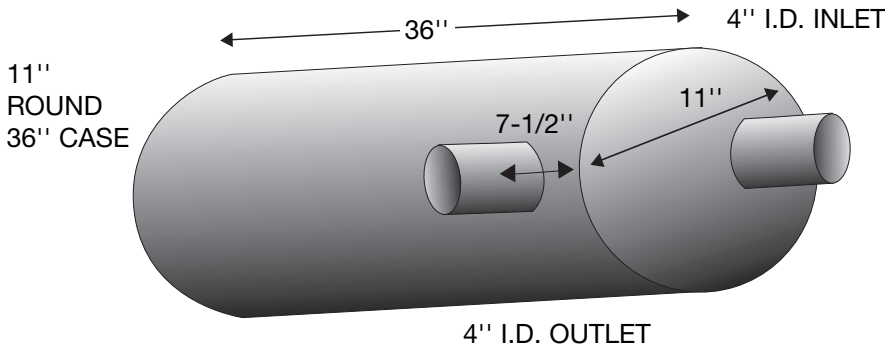

INLET END VIEW

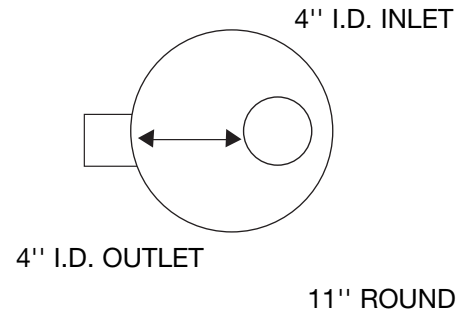

FORD L-SERIES

AUTO-JET PART NO.: 12-0005

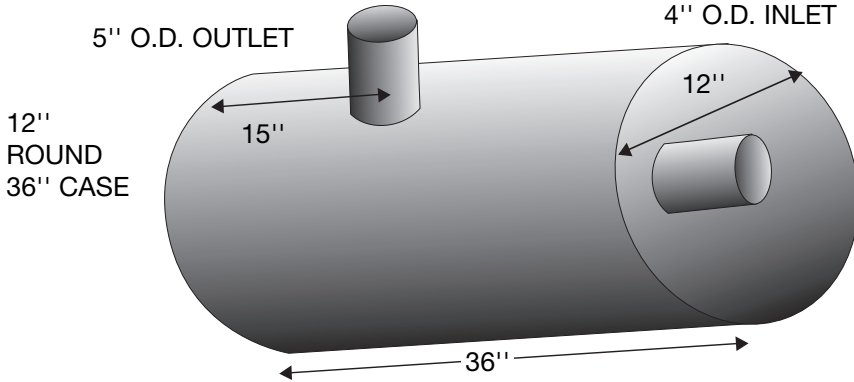

INLET END VIEW

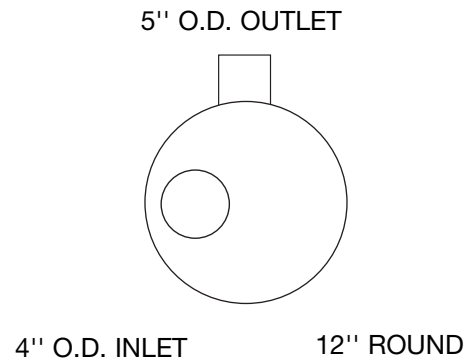

CENTER OF OUTLET 15" FROM END

FORD L-SERIES

**AUTO-JET PART NO.: 12-0010 HEAVY DUTY
86655L ECONOMY**

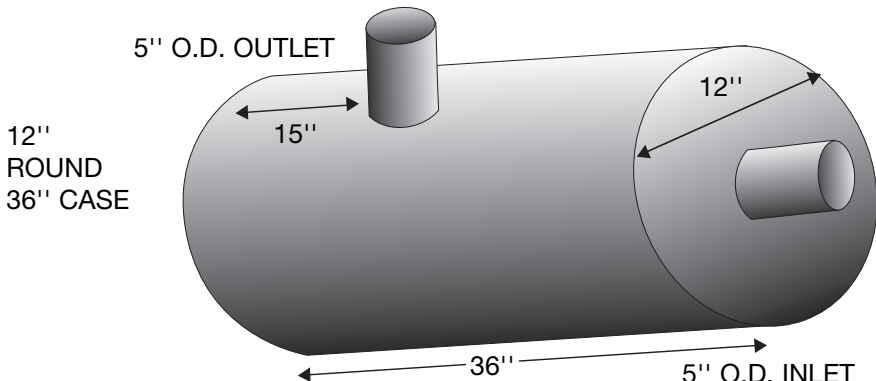

INLET END VIEW

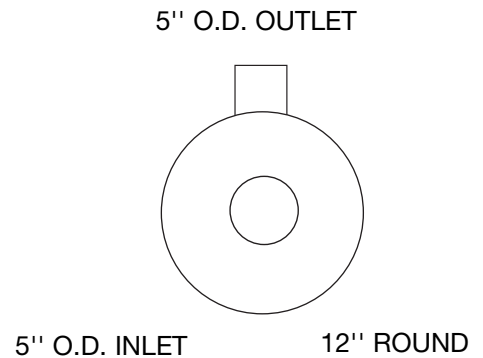

CENTER OF OUTLET 15" FROM END

UNITED MUFFLER CORP.

**U.S. toll free 1-800-247-5391 • Fax 515-224-0727 • website: www.auto-jet.com
Canada toll free 1-866-229-3402 • Fax 519-455-1103 • website: www.unitedmuffler.com**

FORD 18

FORD MUFFLERS

CATALYTIC CONVERTER MUFFLERS

**HORIZONTAL
B-SERIES CUMMINS
PART #: 400FDCAT
C-SERIES CUMMINS
PART #: 400FDCATC**

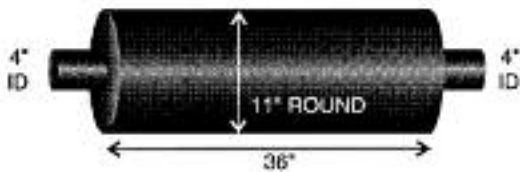

**VERTICAL
B-SERIES CUMMINS
PART #: 400FDCATBV
C-SERIES CUMMINS
PART #: 400FDCATCV**

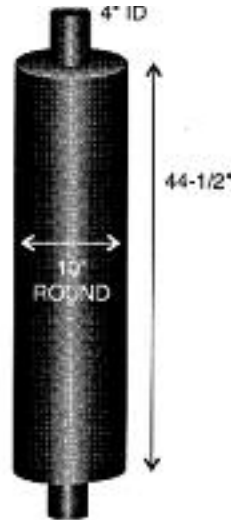

**HORIZONTAL
END IN-SIDE OUT
WITH VERTICAL STACK
B-SERIES CUMMINS
PART #: 110399DB**

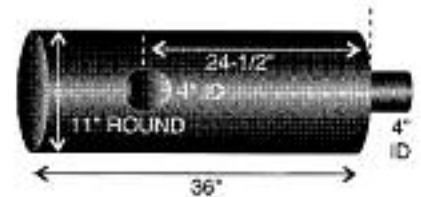

NON-CATALYTIC CONVERTER MUFFLERS

PART #: 11-0025

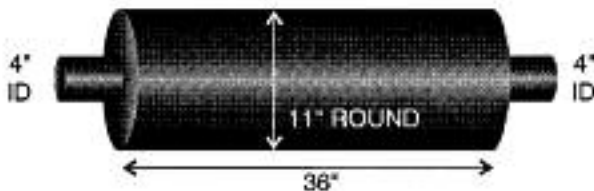

Center In - Center Out

PART #: 11-0035

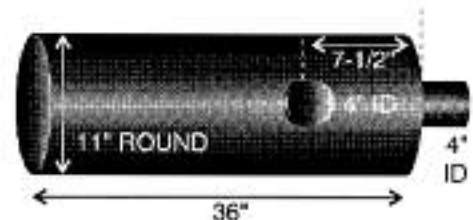

Center In - Side Out

PART #: 11-0030

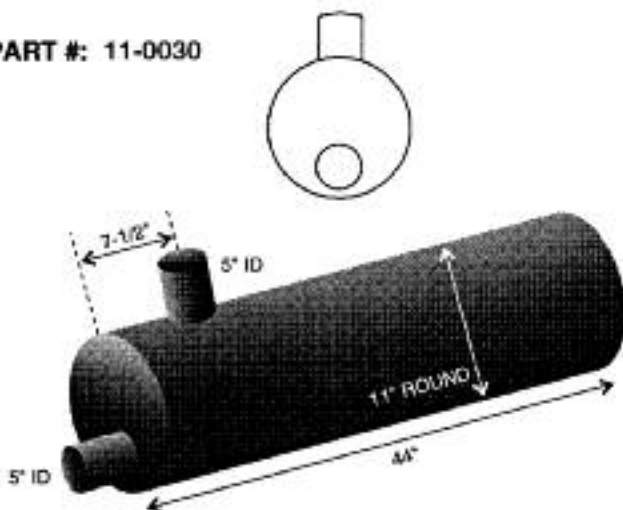

**FORD DOHZ523OK
PART #: 120135D**

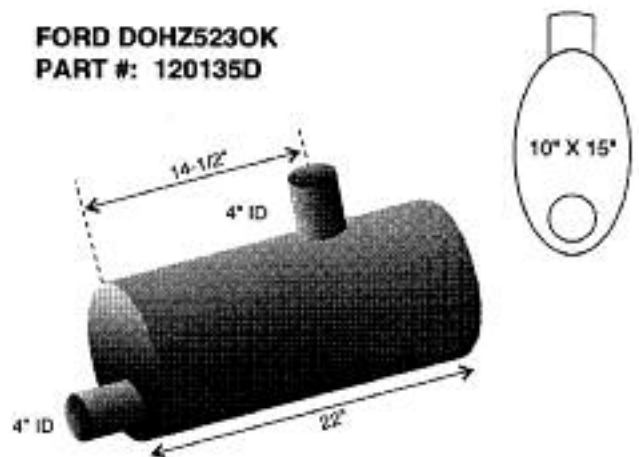

UNITED MUFFLER CORP.

U.S. toll free 1-800-247-5391 • Fax 515-224-0727 • website: www.auto-jet.com
Canada toll free 1-866-229-3402 • Fax 519-455-1103 • website: www.unitedmuffler.com

FORD 19

United #	Sterling/Freightliner #
11-0005	04-19936-004
11-0050	04-20628-001
11-0065	04-20831-000
11-0085	04-18814-007
11-0090	04-17815-001
11-0095	04-19131-005
CUS-106-09	04-22804-000
CUS-175-08	04-20185-000
STER300T	F8HT5246NA
50032E	F6HZ5255AAA
STER3126T	XC455246BA
STERFMMD	F6HZ5A212FA
FDSTAK510	F7HZ5255AAA
F6MOPJ	E7HZ5255D
5A212C	E2HZ5A212C
5A212F	E2HZ5A212F
99290L	EOHZ5A212F
92190L	E2HZ5A212B
5A212B	E0HZ5A212B
46848G	E2HZ5246D
46948G	E2HZ5246E
400FDCAT	F7HZ5F250Y
FRLMH919	A04-20919-000
FRLMH919	A04-20920-000
FRL11MH	A04-17998-001
FRL11MH02	A04-19205-001
FRLMHRUB	04-19919
66F81TURBO	E7HZ5246A

UNITED MUFFLER CORP.

U.S. toll free 1-800-247-5391 • Fax 515-224-0727 • website: www.auto-jet.com
Canada toll free 1-866-229-3402 • Fax 519-455-1103 • website: www.unitedmuffler.com

FORD 20

**CHEVROLET
GMC
EXHAUST
SYSTEMS**



Nationwide toll free 1-866-229-3402

Fax 519-455-1103 • website: www.unitedmuffler.com

CHEVROLET/GMC EXHAUST SYSTEMS

1998-UP 454-502 C.I. GAS Series 60 70 95

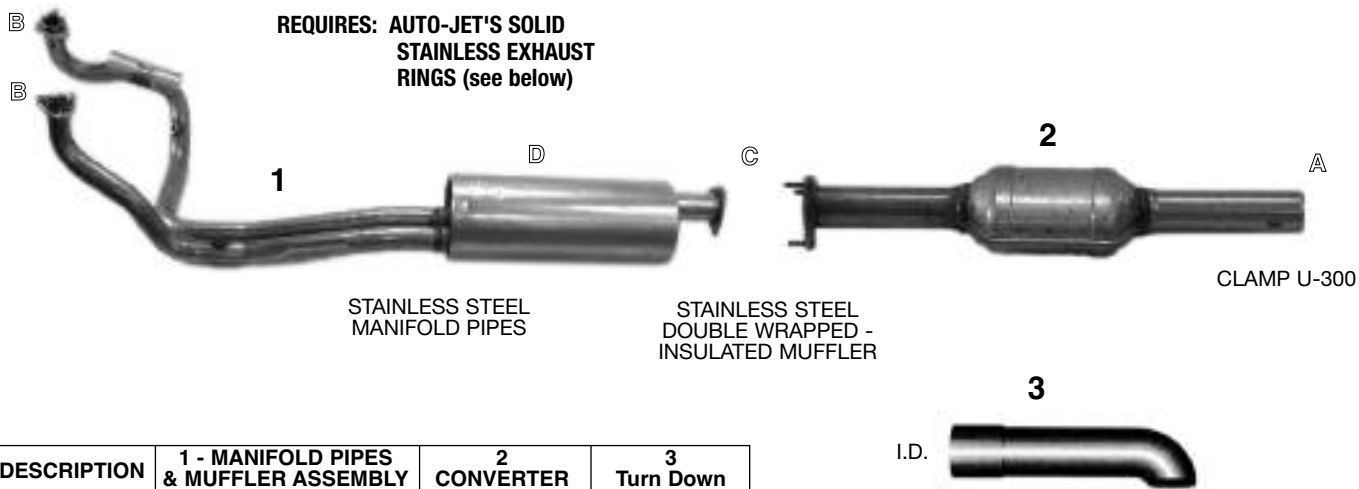

DESCRIPTION	1 - MANIFOLD PIPES & MUFFLER ASSEMBLY	2 CONVERTER	3 Turn Down
PART #	GM454ASSY	GMCONV454	TD300ID

ACCESSORIES

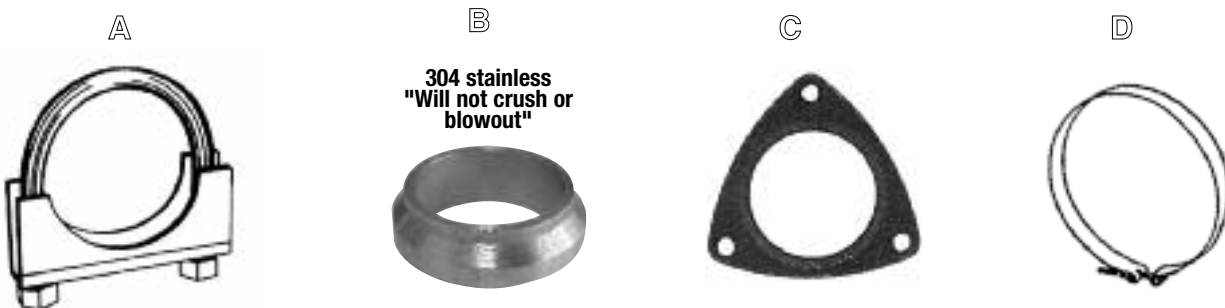

DESCRIPTION	A CLAMPS	B EXHAUST RINGS	C GASKET	D MUFFLER HANGERS
PART #	U-300	454ER304	GMGS3HOLE	GM875MH

UNITED MUFFLER CORP.

U.S. toll free 1-800-247-5391 • Fax 515-224-0727 • website: www.auto-jet.com
 Canada toll free 1-866-229-3402 • Fax 519-455-1103 • website: www.unitedmuffler.com

GM 1

GMC - CHEVROLET EXHAUST SYSTEMS

1997-UP GM 40-50 SERIES KODIAK TOPKICK CHASSIS 6.5 LITRE TURBO DIESEL

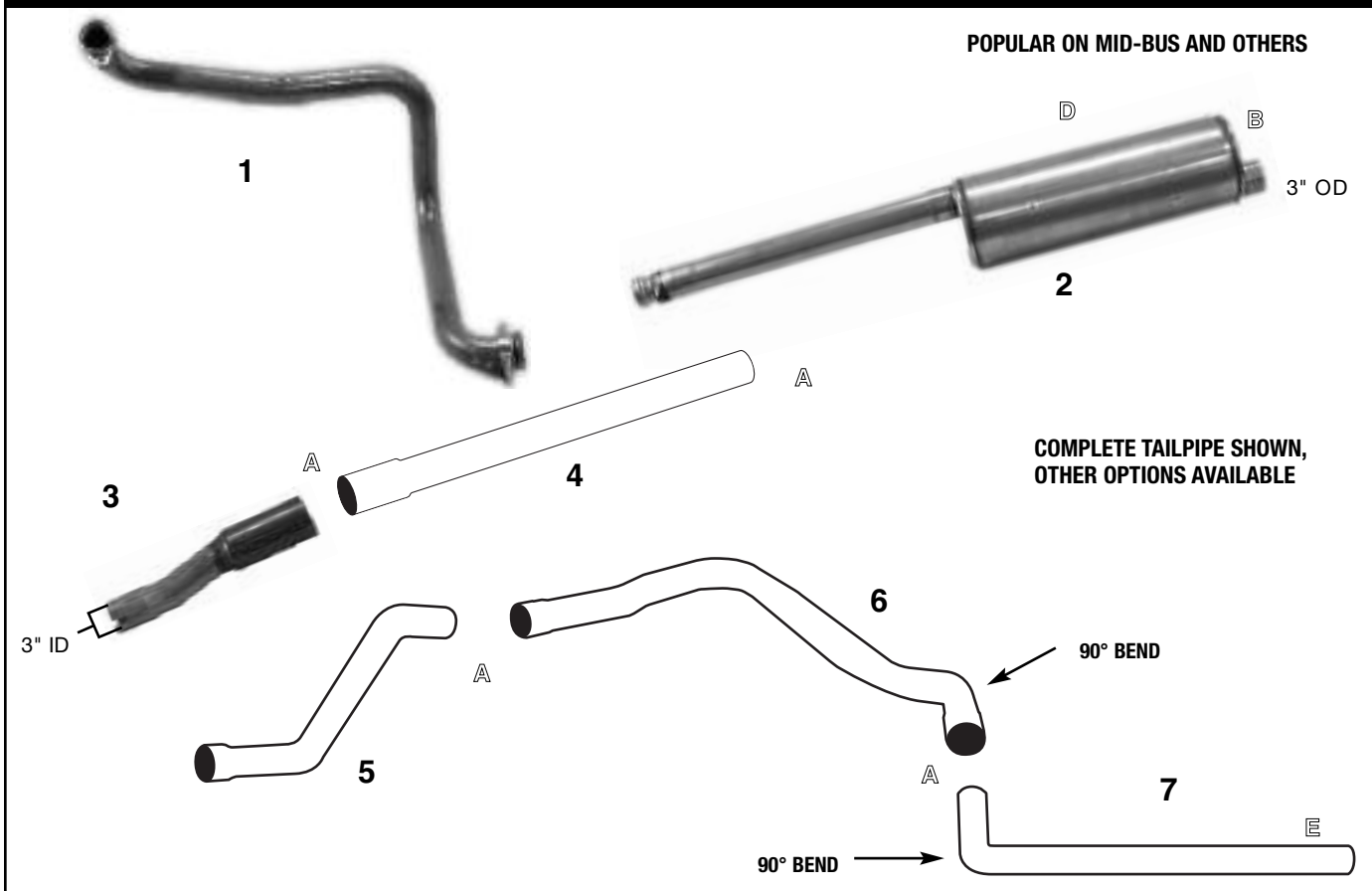

DESCRIPTION	1 TURBO PIPE	2 MUFFLER	3 FRONT PIPE	4 INT. PIPE	5 FRONT OVERAXLE	6 REAR OVERAXLE	7 TAIL PIPE
PART #	GMKOD65T	85-0016	GM454FP	CV400STPID	CVFOA97	CVOA94	CVTP94

ACCESSORIES

DESCRIPTION	OVERAXLE ACCESSORIES		D MUFFLER HANGERS	E TAILPIPE HANGERS
PART #	A 400SCPF	B 300SCPF	GM875MH	GMHGR4

UNITED MUFFLER CORP.

U.S. toll free 1-800-247-5391 • Fax 515-224-0727 • website: www.auto-jet.com
 Canada toll free 1-866-229-3402 • Fax 519-455-1103 • website: www.unitedmuffler.com

CHEVROLET/GMC EXHAUST SYSTEMS

1990-98 TOPKICK/KODIAK C6/C7 WITH 6.6L CAT 3116 ENGINE

SINGLE VERTICAL SYSTEM

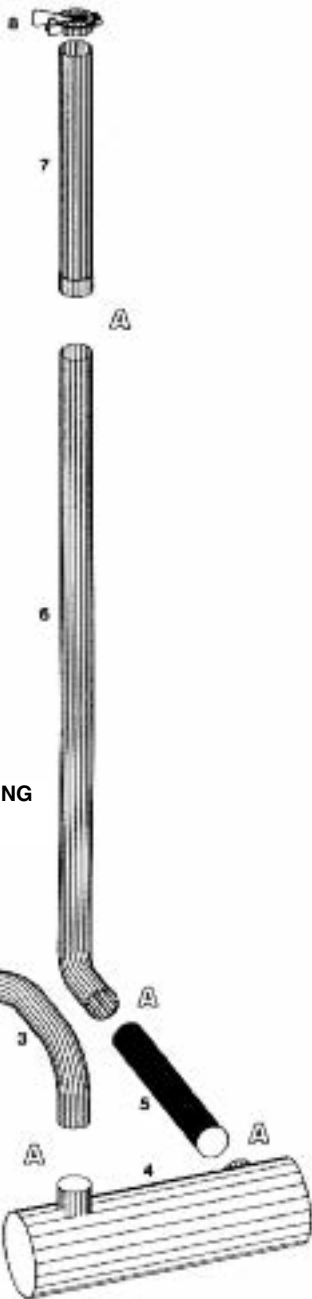

NOTE:
STACK RIGHT (PASSENGER'S SIDE) SHOWN.

FOR TURBO PIPE WITH PYROMETER FITTING
ORDER PART # 3116 KODTPY

ACCESSORIES

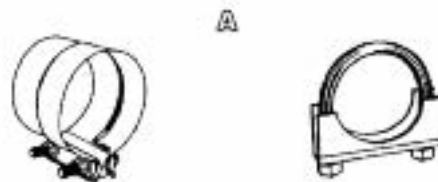

DESCRIPTION	CLAMPS A	
PART #	400SCPF	U-400

DESCRIPTION	1 V-CLAMP	2 TURBO PIPE	3 INTERMEDIATE PIPE	4 MUFFLER	5 FLEX	6 INTERMEDIATE STACK	7 STACK	8 RAIN CAP
STACK RIGHT #	3116VCL	3116KODT	3116EPKOD	86727 or 86725 SEE PAGE GM 16	FLEX40024	STAK470GM	STAK364	RC400
STACK LEFT #	SAME	SAME	SAME	86756				

UNITED MUFFLER CORP.

U.S. toll free 1-800-247-5391 • Fax 515-224-0727 • website: www.auto-jet.com
Canada toll free 1-866-229-3402 • Fax 519-455-1103 • website: www.unitedmuffler.com

CHEVROLET/GMC C-50-60-70-80

1990-UP CHEV. - GMC 3116 CATERPILLAR ENGINE

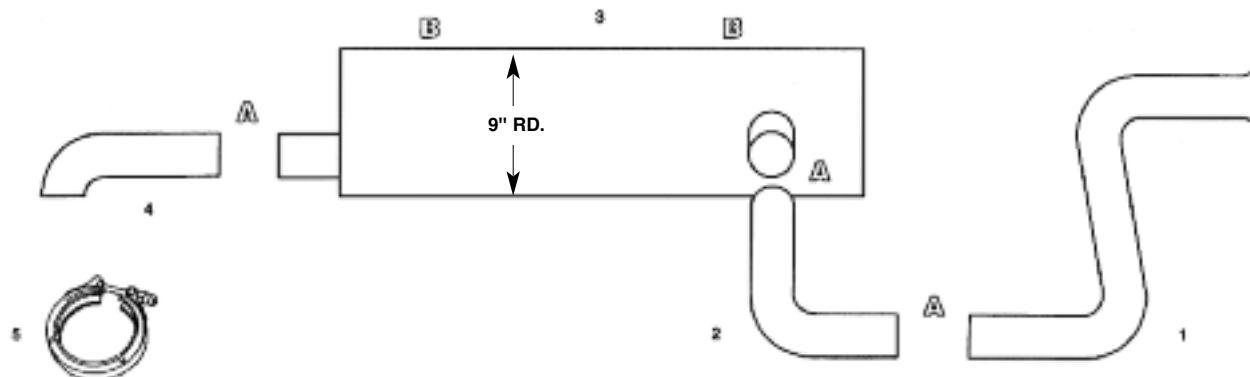

DESCRIPTION	1 - TURBO PIPE	2 - ELBOW	3 - MUFFLER	4 - TURN DOWN	5 - V-VLAMP
PART #	CV3116T	CV3116EL	CV400400	TD400	3116VCL

1990-98 TOPKICK/KODIAK C6, C7 WITH 6.6L CAT 3116 ENGINE

SINGLE HORIZONTAL SYSTEM

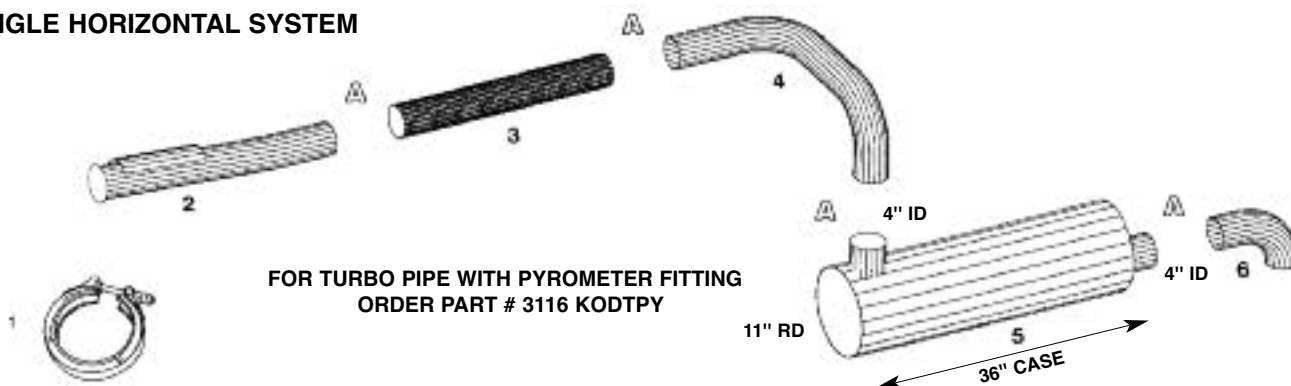

DESCRIPTION	1 V-CLAMP	2 TURBO PIPE	3 FLEX	4 INTERMEDIATE PIPE	5 MUFFLER	6 TAIL PIPE
PART #	3116VCL	3116KODT	FLEX40012	3115EPKOD	72486L	TD400

ACCESSORIES

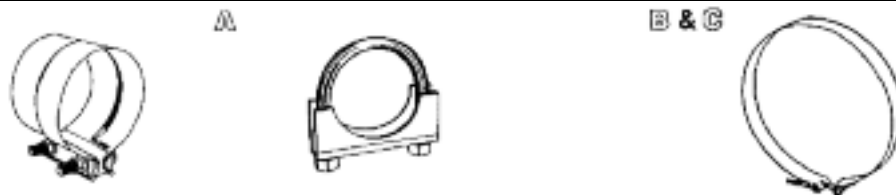

DESCRIPTION	CLAMPS		MUFFLER HANGER	
	A	B	C	
PART #	400SC	U-400	9MHTORCA	1100MH

UNITED MUFFLER CORP.

U.S. toll free 1-800-247-5391 • Fax 515-224-0727 • website: www.auto-jet.com
 Canada toll free 1-866-229-3402 • Fax 519-455-1103 • website: www.unitedmuffler.com

GM 4

CHEVROLET/GMC C-50-60-70-80

1980-87 SERIES 8.2 LITRE NATURALLY ASPIRATED

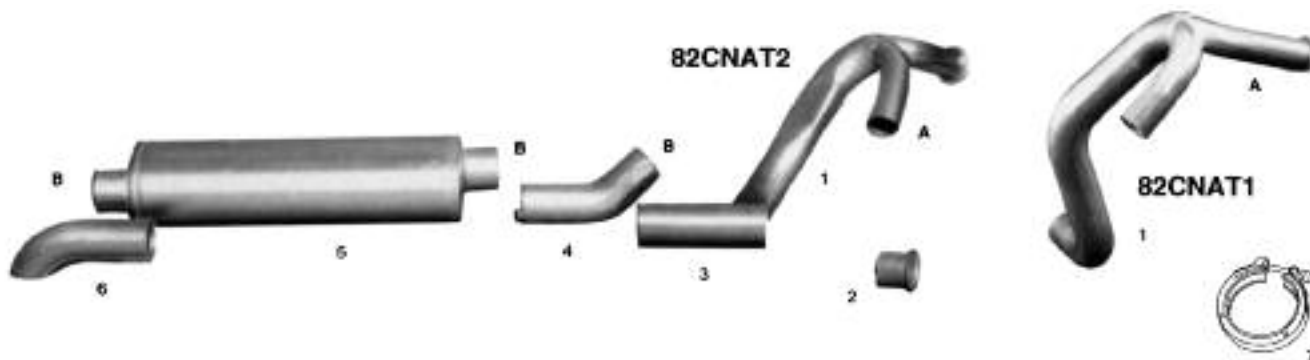

	1 - Y PIPE	2 - Y PIPE RIGHT	3 - FLEX	4 - ELBOW	5 - MUFFLER	6 - TURN DOWN	7 - V-CLAMP
STYLE 1	82CNAT1 OE# 2088280 2090694	82FLARE	82CFLEX18OD	N/R	C-0020 (OVAL)	TD400	82VCLNA
STYLE 2	82CNAT2 OE# 2046392	82FLARE	82CFLEX28	82CNAEL	C-0020 (OVAL)	TD400	82VCLNA

1980-UP CHEVROLET-GMC 8.2 LITRE, TURBO

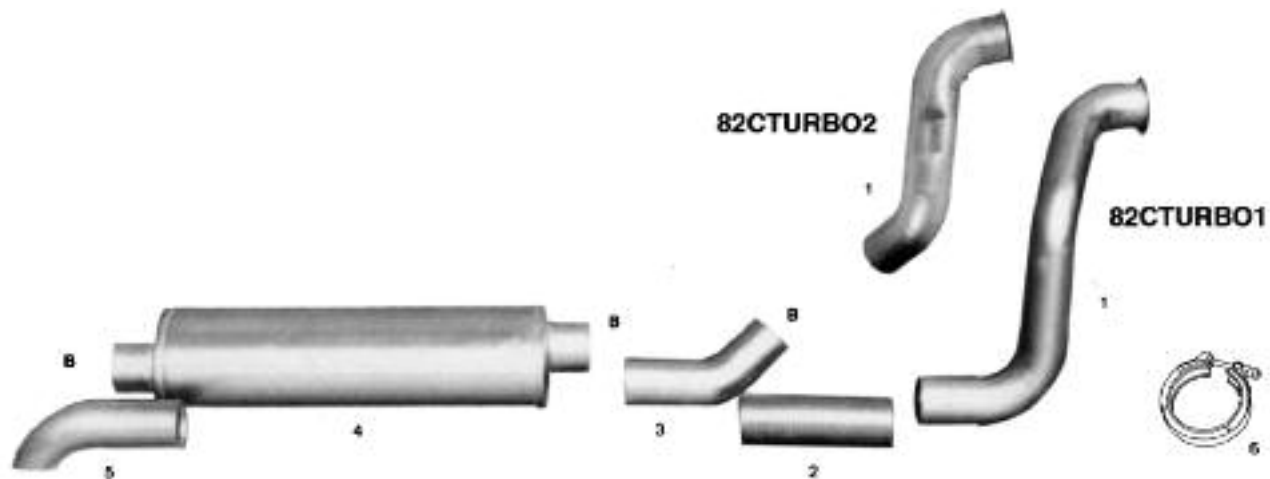

	1 - TURBO PIPE	2 - STAINLESS FLEX	3 - ELBOW	4 - MUFFLER	5 - TURN DOWN	6 - V-CLAMP
STYLE 1	82CTURBO1	82CFLEX18OD	N/R	C-0010	TD400	82VCLT
STYLE 2	82CTURBO2	82CFLEX28	82CNAEL	C-0010	TD400	82VCLT

ACCESSORIES

MUFFLER HANGER



GM OV STRAP

TUBE HANGER



GMHGR4



CLAMPS

A(3")
300SCPF

B(4")
400SCPF
U-400

UNITED MUFFLER CORP.

U.S. toll free 1-800-247-5391 • Fax 515-224-0727 • website: www.auto-jet.com
Canada toll free 1-866-229-3402 • Fax 519-455-1103 • website: www.unitedmuffler.com

CHEVROLET/GMC

1979-86 GMC TOPKICK OR CHEV. KODIAK WITH CAT. 3208 ENGINES

2-PIECE Y & CROSSOVER

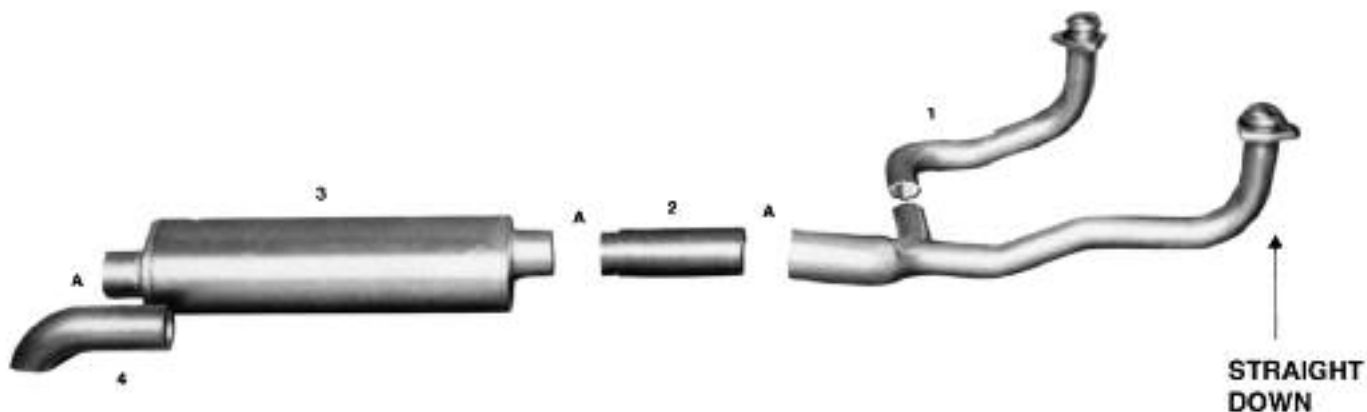

1 - MANIFOLD PIPE	2 - FLEX	3 - MUFFLER	4 - TURN DOWN
GM 320879S	FLEX40024OD	C-0010	TD400

1983-UP MODELS C60, C70 WITH 3208 CAT. ENGINES

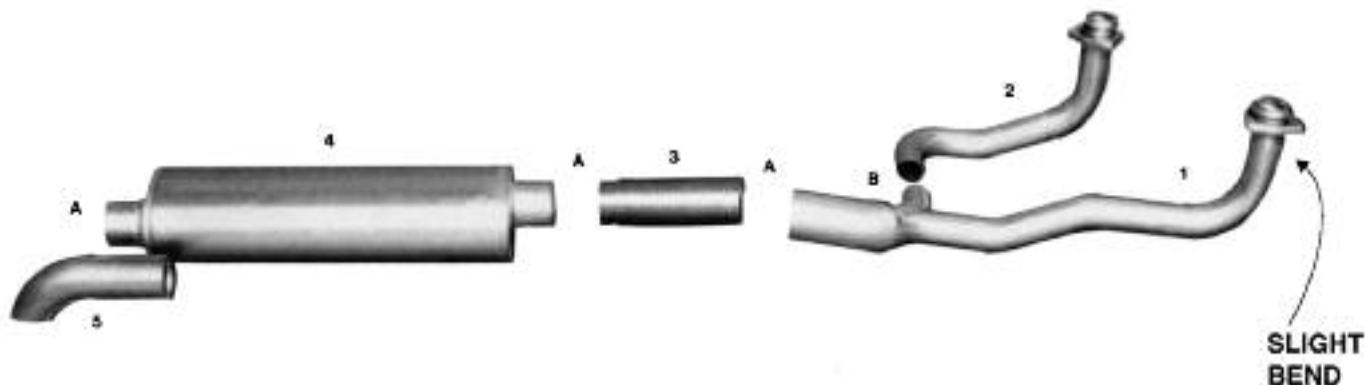

1 - EXHAUST PIPE RIGHT	2 - EXHAUST PIPE LEFT	3 - FLEX	4 - MUFFLER	5 - TURN DOWN
GM 3208Y83	GM 3208C083	FLEX40024OD	C-0010	TD400

ACCESSORIES

MUFFLER HANGER



GM OV STRAP

TUBE HANGER



GMHGR4



CLAMPS

A(4")	B(2 ³ / ₄ ")
400SC[F	275SCPF
U-400	U-275

UNITED MUFFLER CORP.

U.S. toll free 1-800-247-5391 • Fax 515-224-0727 • website: www.auto-jet.com
 Canada toll free 1-866-229-3402 • Fax 519-455-1103 • website: www.unitedmuffler.com

GM 6

CHEVROLET/GMC SERIES 50-60-70-80

1989-UP 8 CYL. W/366 C.I.D. (7.0L) T.B.I. ENG. W/CONVERTER

STAINLESS STEEL SYSTEM

FOR SOLID STAINLESS
EXHAUST RINGS SEE ACC 13
"WILL NOT BLOW OUT"

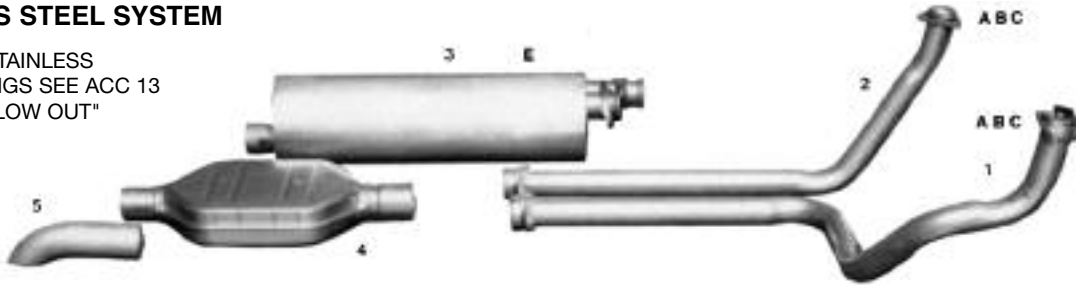

1 - RIGHT MANIFOLD PIPE		2 - LEFT MANIFOLD PIPE		3 - MUFFLER	4 - CONVERTER	5 - TURN DOWN
1989-91	TBIRM		TBILM	2-250300BS	GMCONV	TD300
1992-97	CV366R		CV366L	2-250300BS	GMCONV	TD300

1986-90 8 CYL. W/366, 427 C.I.D.

STAINLESS STEEL SYSTEM

FOR SOLID STAINLESS
EXHAUST RINGS SEE ACC 13
"WILL NOT BLOW OUT"

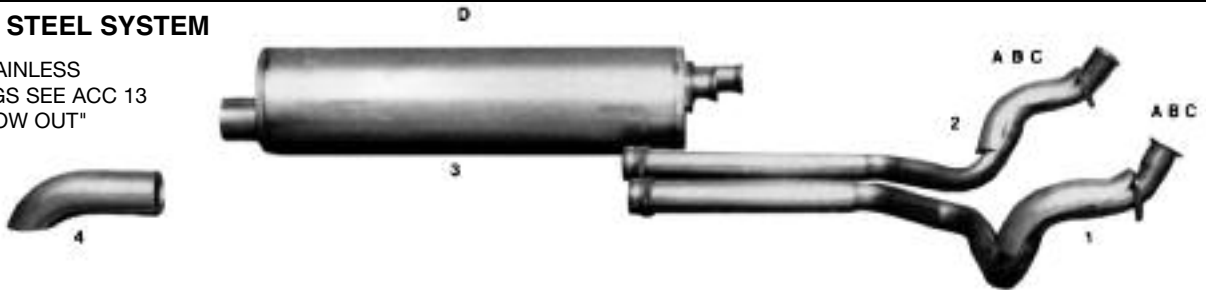

1 - RIGHT MANIFOLD PIPE		2 - LEFT MANIFOLD PIPE		3 - MUFFLER	4 - TURN DOWN
	366SSR6		366SSL6	2-250400BS	TD400

ACCESSORIES

EXHAUST RING



366ERSS

SPRINGS



SPRINGSS

STUDS



STUDSS

MUFFLER HANGERS



GM10MH



GM875MH



GM7MH

UNITED MUFFLER CORP.

U.S. toll free 1-800-247-5391 • Fax 515-224-0727 • website: www.auto-jet.com
Canada toll free 1-866-229-3402 • Fax 519-455-1103 • website: www.unitedmuffler.com

GM 7

CHEVROLET/GMC SERIES 50-60-70-80

1980-90 8 CVL. W/366, 427 C.I.D. (BALL & SOCKET JOINT)

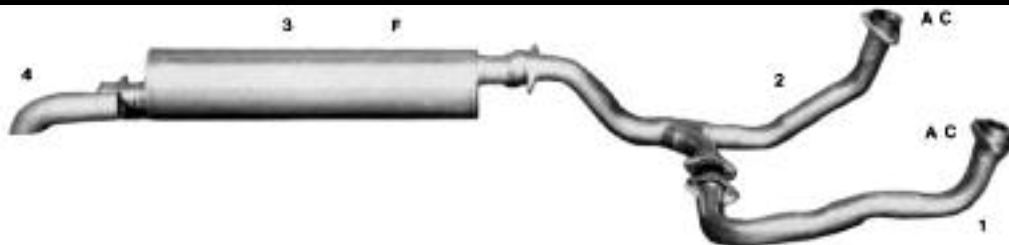

	1 - RIGHT MANIFOLD PIPE	2 - LEFT MANIFOLD PIPE	3 - MUFFLER	4 - TURN DOWN
JOIN BEHIND CROSSMEMBER	366LCOB	366LYB	275275BTD	TD275
JOIN IN FRONT OF CROSSMEMBER	366LCOF	366LYF	275275BTD	TD275

ACCESSORIES

EXHAUST RINGS



HEAT INHIBITORS



MUFFLER HANGERS



UNITED MUFFLER CORP.

U.S. toll free 1-800-247-5391 • Fax 515-224-0727 • website: www.auto-jet.com
 Canada toll free 1-866-229-3402 • Fax 519-455-1103 • website: www.unitedmuffler.com

GM 8

CHEVROLET - GMC VAN EXHAUST SYSTEM

1998-UP G-SERIES VAN, 6.5 LITRE DIESEL TURBO PIPE

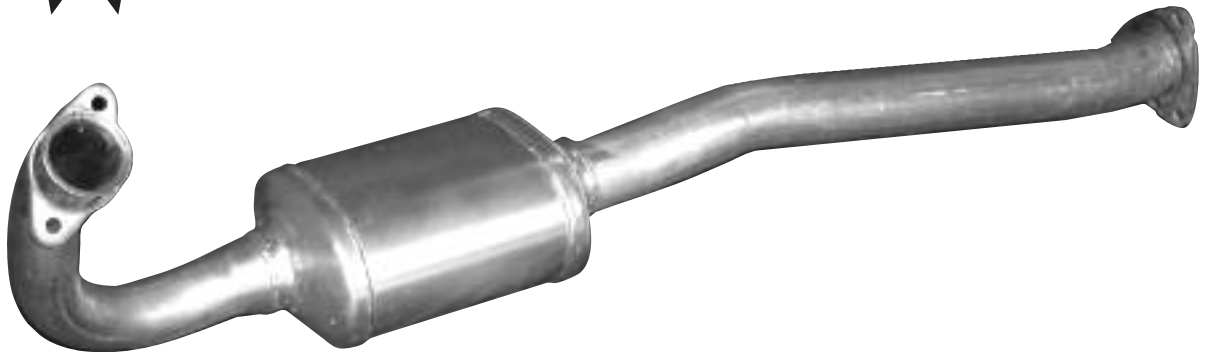

SEE BELOW FOR
MUFFLER AND
TAILPIPES

PART # 65GCONVT
GASKET PART # GMGS3HOLE

G-30 & G-3500 SERIES, 6.5L DIESEL MUFFLER & TAILPIPES

BELLOWS OPTIONAL



NOTE: Muffler has
3-hole flange inlet.

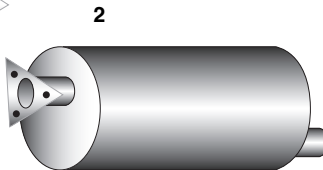

NOTE: Original
Equipment has 3-hole
flanges connecting the
extension pipe to the
muffler. Auto-Jet is slip fit.
Flanged Connection is available.

3 - SPECIFY RIGHT SIDE OR REAR EXIT

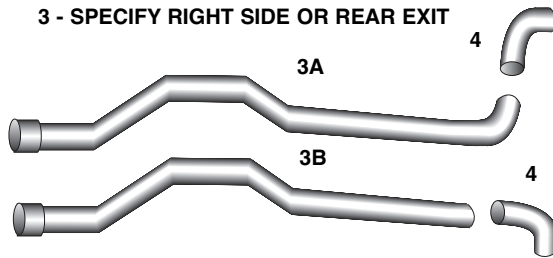

OE # 15739326 MUFFLER AND TAIL PIPE WELDED ASSEMBLY.

DESCRIPTION	1 - FRONT EXTENSION	2 - MUFFLER	3 - TAIL PIPE		4 - TURNOUT
			A - RIGHT SIDE EXIT	B - REAR EXIT	
PART #	65GEXTFL	65G300FL	65G275TPRH	65G275TPOR	TD275

UNITED MUFFLER CORP.

U.S. toll free 1-800-247-5391 • Fax 515-224-0727 • website: www.auto-jet.com
Canada toll free 1-866-229-3402 • Fax 519-455-1103 • website: www.unitedmuffler.com

GM 9

CHEV./GMC CUTAWAY VAN EXHAUST SYSTEMS

1998-UP G-30 & G-3500 SERIES VAN, 350 C.I.

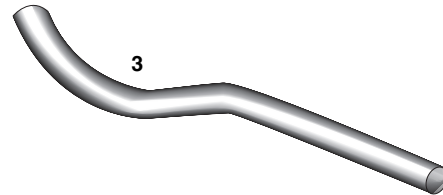
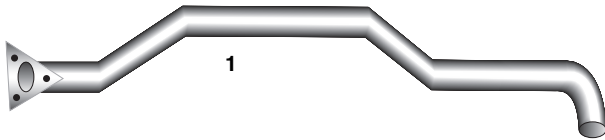

EXTENSION PIPE, MUFFLER & TAIL PIPE
OE WELDED ASSEMBLY
OE # 15734043
MODEL: CUT AWAY VAN

MUFFLER SITS CROSS-WAYS

DESCRIPTION	1 - EXTENSION PIPE	2 - MUFFLER	3 - TAIL PIPE
PART #	G30SAVEXT	G30SAV300	G30SAVTP

1994-UP G-30 & G-3500 SERIES, 6.5L DIESEL

SPECIFY WHEEL BASE 125" OR 146"
EXHAUST RING: #GM62ER
146" W.B. EXTENSION PART# 300EXT

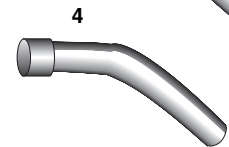
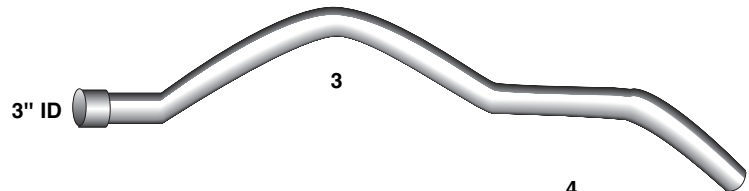
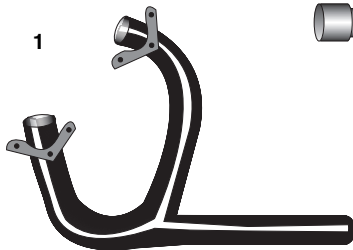

STAINLESS STEEL

DESCRIPTION	1 - MANIFOLD PIPE	2 - MUFFLER	3 - TAIL PIPE	4 - WIDE BODY EXTENSION
PART #	65GYSS	GM65300G	GMGTP92	WBEXT92

UNITED MUFFLER CORP.

U.S. toll free 1-800-247-5391 • Fax 515-224-0727 • website: www.auto-jet.com
Canada toll free 1-866-229-3402 • Fax 519-455-1103 • website: www.unitedmuffler.com

GM 10

CHEVROLET/GMC MUFFLERS

END INLET - END OUTLET

AUTO-JET PART NO.: 275275B
APPLICATION: GAS
ENGINE: 350 C.I. - 366 C.I. - 427 C.I.
YEAR: 1979 TO 1984

2-3/4" BALL
CONNECTION OUTLET -
OFFSET

7"
ROUND



34-1/2" CASE

2-3/4" SOCKET CONNECTION INLET - OFFSET

MUFFLER HANGER



#700MH

AUTO-JET PART NO.: 10-0060
APPLICATION: DIESEL
ENGINE: 3116 CAT.
YEAR: 1992 & UP

4" CENTERED OUTLET

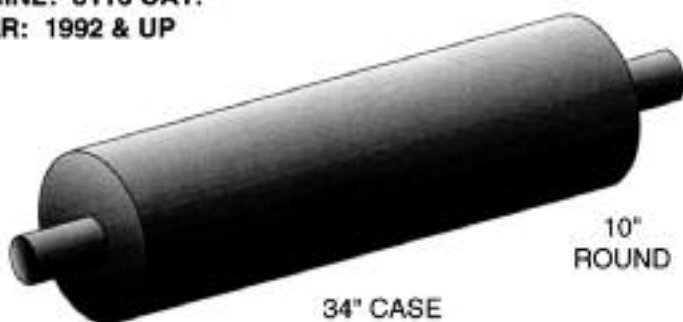

10"
ROUND

34" CASE

4" CENTERED INLET

MUFFLER HANGER



#GM10MH

AUTO-JET PART NO.: C-0020 NATURALLY ASP.
AUTO-JET PART NO.: C-0010 TURBO
APPLICATION: DIESEL
ENGINE: 8.2 LITRE
YEAR: 1980 TO 1990

4" OUTLET - OFFSET

8-1/4 X 11"
OVAL



32" CASE
NATURALLY ASP.

27" CASE
TURBO

4" INLET - OFFSET

MUFFLER STRAP
DIESEL



#GMOVSTRAP

UNITED MUFFLER CORP.

U.S. toll free 1-800-247-5391 • Fax 515-224-0727 • website: www.auto-jet.com
Canada toll free 1-866-229-3402 • Fax 519-455-1103 • website: www.unitedmuffler.com

GM 11

CHEVROLET/GMC MUFFLERS

STAINLESS STEEL / END INLET - END OUTLET

AUTO-JET PART NO.: 2250400BS
APPLICATION: GAS
ENGINE: 366 C.I. - 427 C.I.
YEAR: 1986 TO 1989

4" OFFSET OUTLET

10" ROUND

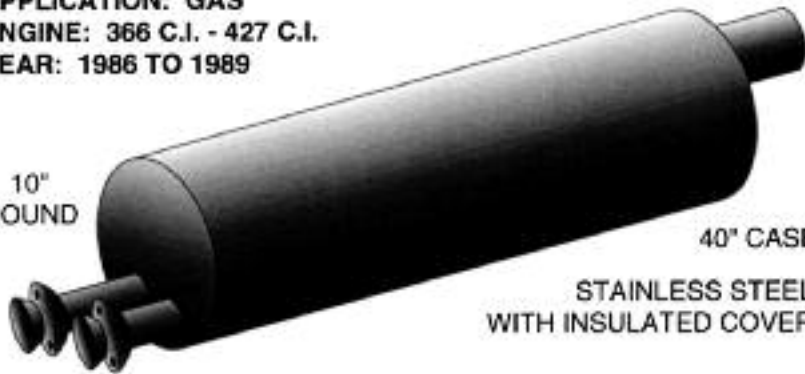

40" CASE

STAINLESS STEEL
WITH INSULATED COVER

DUAL INLETS - 2-1/2" SOCKET CONNECTION

**SHIELD
HANGER**



#GM10HS

**MUFFLER
HANGER**



#GM10MH

FRAME BRACKETS



FRONT
#GM10BRFT



REAR
#GM10BRRE

AUTO-JET PART NO.: 2250300BS
APPLICATION: GAS
ENGINE: 366 C.I. - 427 C.I.
YEAR: 1989 & UP

3" OUT TO CONVERTER

8-3/4" ROUND

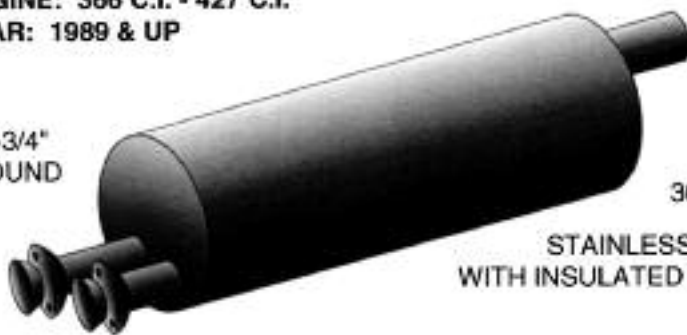

30" CASE

STAINLESS STEEL
WITH INSULATED COVER

DUAL INLETS - 2-1/2" SOCKET CONNECTION

MUFFLER HANGER

#GM875MH



BRACKETS



MUFFLER
#GM875BR



FRAME
#GM875FRBR

AUTO-JET PART NO.: 275275BS
APPLICATION: GAS
ENGINE: 350 C.I., 366-427 C.I.
YEAR: 350 C.I. - 1985 & UP
 366-427 C.I. 1985 & 1986

2-3/4" BALL
CONNECTION OUTLET -
OFFSET

7" ROUND

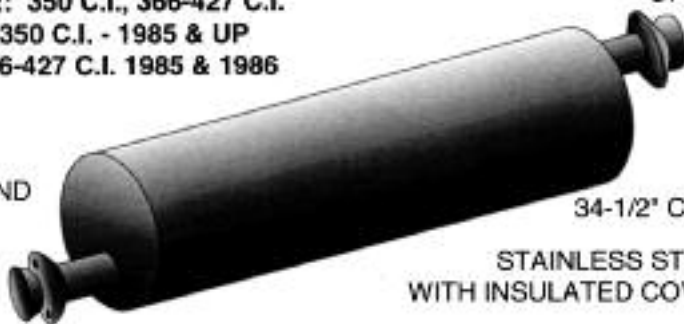

34-1/2" CASE

STAINLESS STEEL
WITH INSULATED COVER

2-3/4" SOCKET CONNECTION INLET - OFFSET

SHIELD



1985 & UP 350 C.I.,
1985 & 1986 366-427 C.I.
WITH TWO MUFFLERS

#GM7SHLD

MUFFLER HANGER



#GM7MH

UNITED MUFFLER CORP.

U.S. toll free 1-800-247-5391 • Fax 515-224-0727 • website: www.auto-jet.com
 Canada toll free 1-866-229-3402 • Fax 519-455-1103 • website: www.unitedmuffler.com

GM 12

CHEVROLET/GMC MUFFLERS



END INLET - SIDE OUTLET

AUTO-JET PART NO.: S-198-92

SIDE OUTLET

GM Part No. 15552515

19" FROM EDGE OF CASE
TO OUTLET

4" I.D. OUT

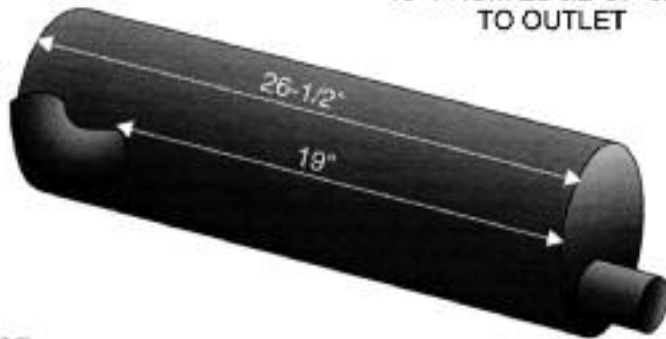

26-1/2" CASE

4" O.D. INLET

INLET END VIEW

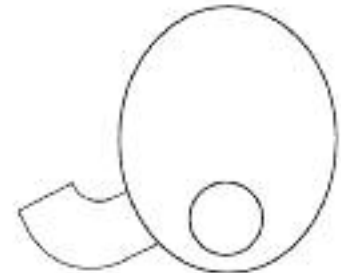

AUTO-JET PART NO.: S-247-92

SIDE OUTLET

GM Part No. 15504836

7" FROM BACK OF CASE
TO CENTER OF OUTLET

4" I.D. OUT

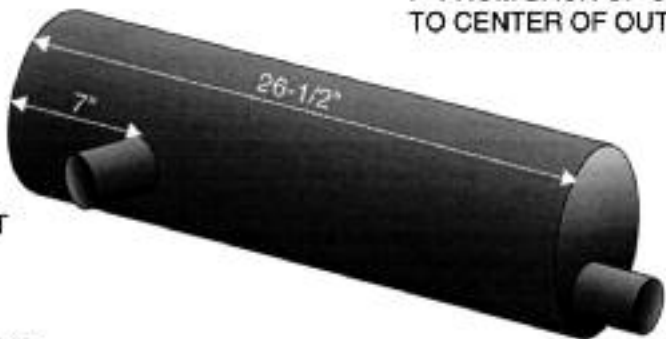

26-1/2" CASE

4" O.D. INLET

INLET END VIEW

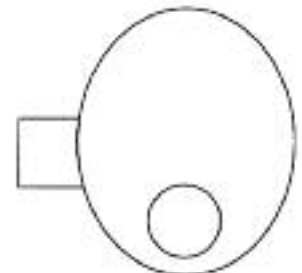

AUTO-JET PART NO.: S-243-92

SIDE OUTLET

GM Part No. 2005719

5" FROM BACK OF CASE
TO CENTER OF OUTLET

4" I.D. OUT



27" CASE

4" O.D. INLET

INLET END VIEW

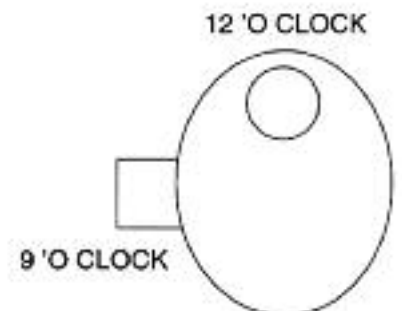

UNITED MUFFLER CORP.

U.S. toll free 1-800-247-5391 • Fax 515-224-0727 • website: www.auto-jet.com
Canada toll free 1-866-229-3402 • Fax 519-455-1103 • website: www.unitedmuffler.com

GM 13



CHEVROLET/GMC

MISCELLANEOUS MUFFLERS

AUTO-JET PART NO.: 59786L
SIDE
OUTLET

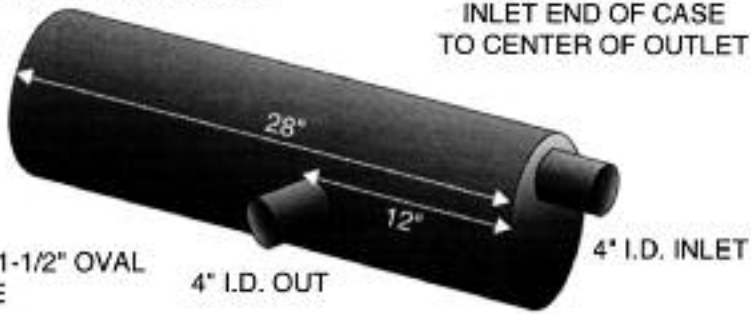

8-1/4 X 11-1/2" OVAL
 28" CASE

12" FROM
 INLET END OF CASE
 TO CENTER OF OUTLET

INLET END VIEW
 12 O'CLOCK
 8 O'CLOCK

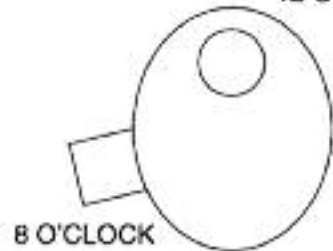

8-1/4 X 11-1/2" OVAL

AUTO-JET PART NO.: 72486L
TOP INLET - END OUTLET
ENGINE: 3116 CAT.,
KODIAK & TOPKICK

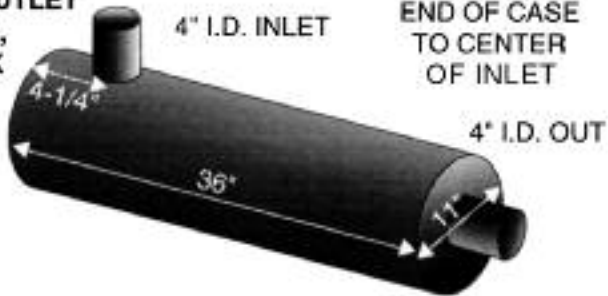

GM Part No.
 15552174
 15609879

11" ROUND
 36" CASE

4-1/4" FROM
 END OF CASE
 TO CENTER
 OF INLET

INLET END VIEW
 12 O'CLOCK

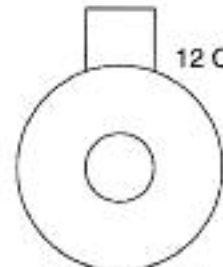

11" ROUND

AUTO-JET PART NO.: CV400400
SIDE INLET - END OUTLET
APPLICATION: DIESEL
ENGINE: 3116 CAT.
YEAR: 1992 & UP



4" CENTERED OUTLET

9" ROUND
 42" CASE

4-1/2" FROM
 END OF CASE
 TO CENTER OF INLET

MUFFLER HANGER



#GM875MH

4" SIDE INLET

CHEVROLET/GMC TILTMASER - ISUZU

AUTO-JET PART NO.: 69086L
END INLET - END OUTLET
HEAVY DUTY



3-3/16" I.D.
 OUTLET

10" ROUND
 23.5" CASE
 (28-5/8" END TO END)

Fits 86-90 Chev./GMC
 6 cyl. W6, W7 Tiltmaster
 and 86-90 Isuzu Trk.
 6 cyl. FSR, FTR, FVR, EVR
 GM Part No. 9404 4319
 9404 7627

INLET END VIEW

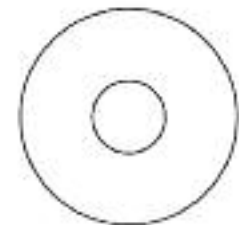

10" ROUND

UNITED MUFFLER CORP.

U.S. toll free 1-800-247-5391 • Fax 515-224-0727 • website: www.auto-jet.com
 Canada toll free 1-866-229-3402 • Fax 519-455-1103 • website: www.unitedmuffler.com

TOP INLET - SIDE OUTLET

AUTO-JET PART NO.: 86756
TOP INLET - SIDE OUTLET
GM# 15628117

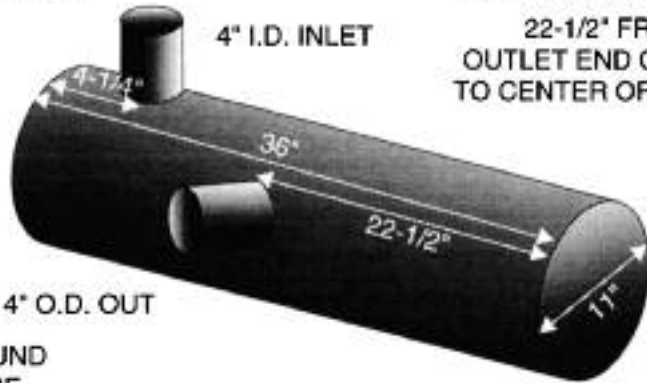

11" ROUND
 36" CASE

4-1/4" FROM
 INLET END OF CASE
 TO CENTER OF INLET
 22-1/2" FROM
 OUTLET END OF CASE
 TO CENTER OF OUTLET

INLET END VIEW

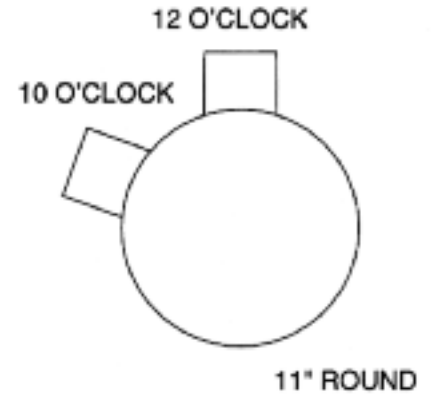

AUTO-JET PART NO.: 86727
TOP INLET - SIDE OUTLET
GM# 15572772
& 15572771

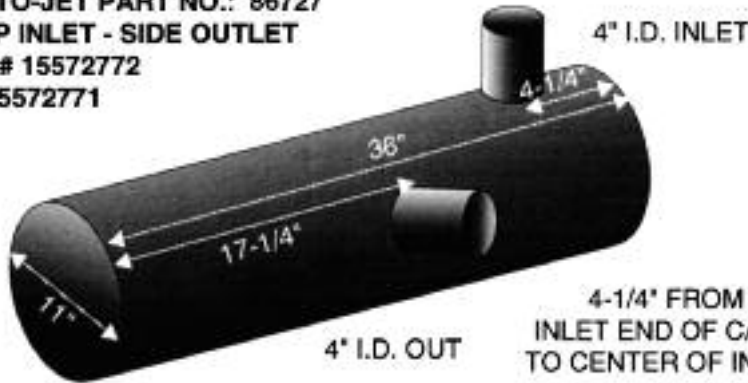

11" ROUND
 36" CASE

4-1/4" FROM
 INLET END OF CASE
 TO CENTER OF INLET
 17-1/4" FROM
 OUTLET END OF CASE
 TO CENTER OF OUTLET

INLET END VIEW

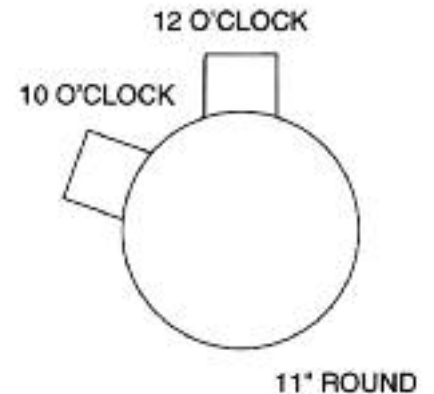

AUTO-JET PART NO.: 86725
TOP INLET - SIDE OUTLET
GM# 15658354

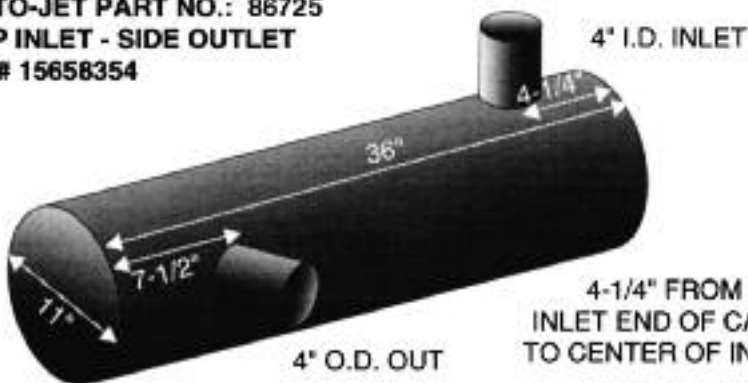

11" ROUND
 36" CASE

4-1/4" FROM
 INLET END OF CASE
 TO CENTER OF INLET
 7-1/2" FROM
 OUTLET END OF CASE
 TO CENTER OF OUTLET

INLET END VIEW

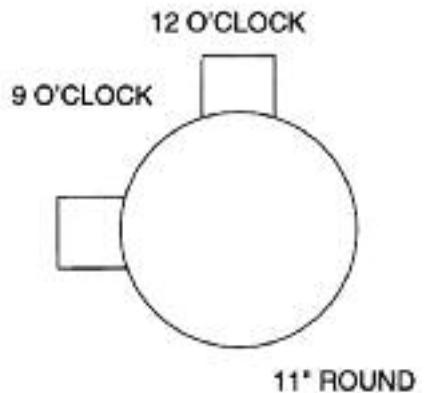

United #	CHEV/GM #
GM875MH	15642936
GMHGR4	15053749
GMKOD65T	15736780
GM454FP	15737613
CVFOA97	15977592
CVFOA94	15964688
CVTP94	15964689
82CNAT1	2088280
82CNAT2	2046392
65GCONVT	15729713
GMGS3HOLE	15733803
65GEXTFL	15734030
65G300FL	15739326
G30SAV300	15734043
65GYSS	15693182
GM65300G	15685647
GM10MH	15555590
GM875BR	15725934
86756	15628117
86727	15572772
86725	15658354
GMDIFF	25996745
CV3126T	15743050

UNITED MUFFLER CORP.

U.S. toll free 1-800-247-5391 • Fax 515-224-0727 • website: www.auto-jet.com
Canada toll free 1-866-229-3402 • Fax 519-455-1103 • website: www.unitedmuffler.com

GM 16

NAVISTAR EXHAUST SYSTEMS



Nationwide toll free 1-866-229-3402

Fax 519-455-1103 • website: www.unitedmuffler.com

NAVISTAR INTERNATIONAL EXHAUST SYSTEMS

2000-UP INTERNATIONAL DT 466 ENGINE WITH LEFT SIDE EXHAUST SYSTEM

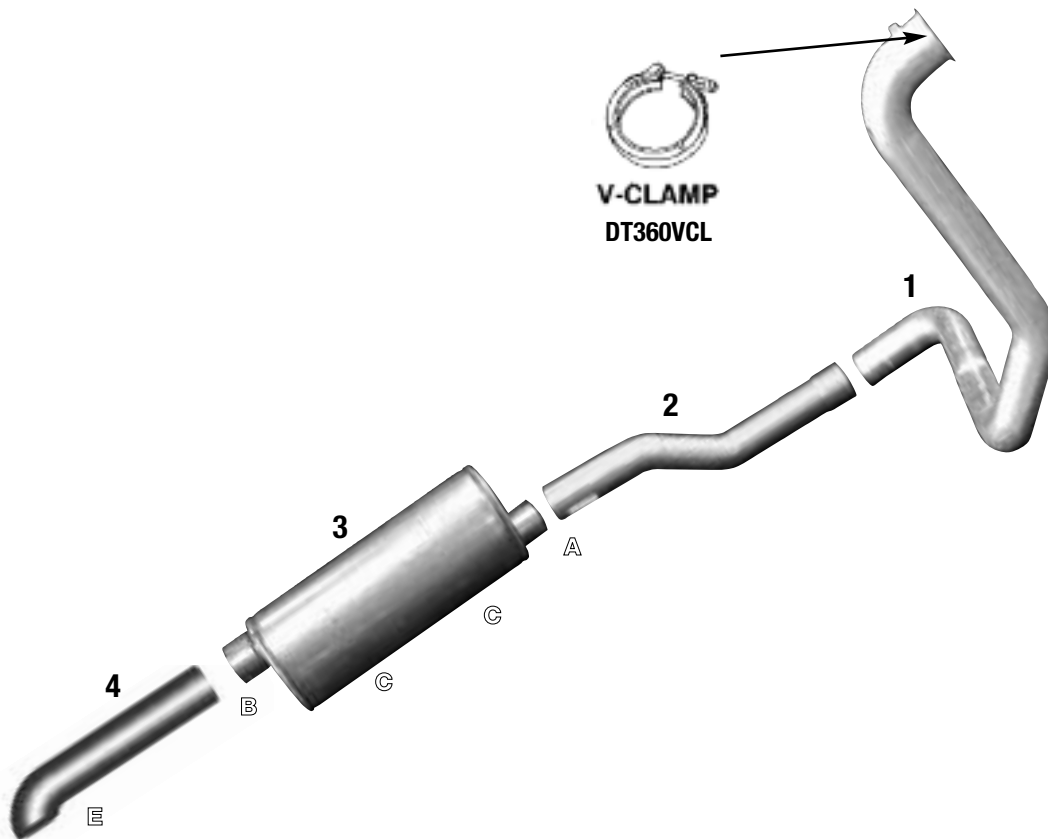

DESCRIPTION	1 TURBO PIPE	2 - TURBO PIPE EXTENSION	3 MUFFLER	4 TURN DOWN
PART #	466DTLE20	NAVEXT20	C-0025	TD400OD

ACCESSORIES



Stainless Clamps
See page ACC 2 for more information

DESCRIPTION	CLAMPS			MUFFLER HANGERS
		A -3-1/2"	B -4"	
PART #	FLAT	350SC	400SC	OVMHIHRE
	PRE-FORMED	350SCPF	400SCPF	
	U-BOLT	U-350	U-400	

UNITED MUFFLER CORP.

U.S. toll free 1-800-247-5391 • Fax 515-224-0727 • website: www.auto-jet.com
 Canada toll free 1-866-229-3402 • Fax 519-455-1103 • website: www.unitedmuffler.com

INTERNATIONAL MEDIUM DUTY TRUCKS

1986-UP NAVISTAR DT466 VERTICAL SYSTEM

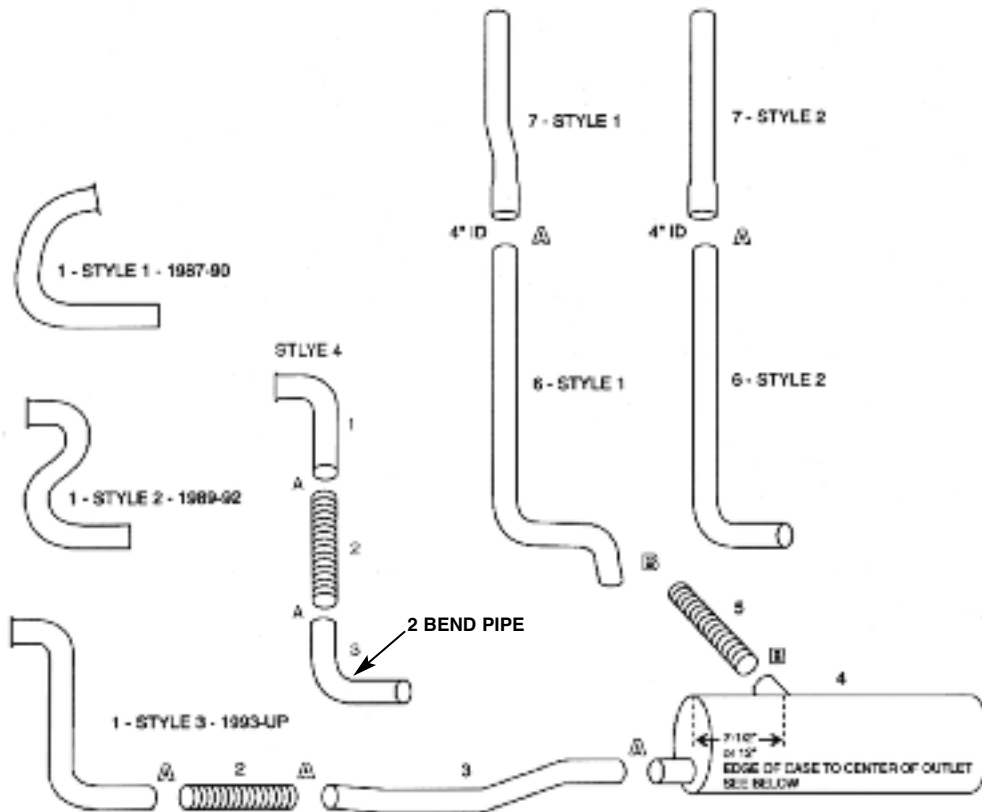

DESCRIPTION	1 TURBO PIPE	2 FLEX	3 - EXHAUST PIPE REAR	4 MUFFLER	5 FLEX	6 - LOWER STACK	7 - UPPER STACK
STYLE 1 PART #	96690L	FLEX35012	96790L	7-1/2" DISTANCE NAV-0005	FLEX40036	NAVSTAK1LO 925047A	NAVSTAK1UP
STYLE 2 PART #	466T89	—	—	12" DISTANCE NAV-0010	—	NAVSTAK2LO	NAVSTAK2UP
STYLE 3 PART #	466T93	—	—	—	—	—	—
STYLE 4 PART #	466TDOT93	—	46693DOTEXT	—	—	—	—

ACCESSORIES

FOR MUFFLER HANGERS
SEE PAGE NAV 9

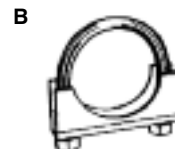

DESCRIPTION	A CLAMPS			B
PART #	350SCPF	U-350	400SCPF	U-400

UNITED MUFFLER CORP.

U.S. toll free 1-800-247-5391 • Fax 515-224-0727 • website: www.auto-jet.com
Canada toll free 1-866-229-3402 • Fax 519-455-1103 • website: www.unitedmuffler.com

NAVISTAR INTERNATIONAL

1994-UP T444E MODEL 4700 3-1/2" FRONT PIPES

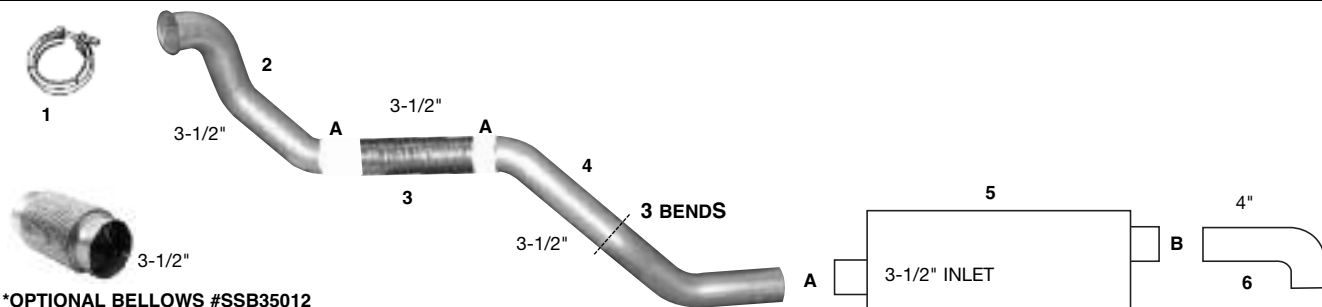

*OPTIONAL BELLOWS #SSB35012

1 - V-CLAMP	2 - TURBO PIPE	3 - FLEX	4 - FLEX TO MUFFLER PIPE	5 - MUFFLER	6 - TURN DOWN
AUTO-JET PART NUMBER					
NAVCL428	T444T35MD	FLEX35012	T444FM35MD	C-0025	TD400
O.E. PART NUMBER					
893944R92	2033702C1	753329C1	2033703C1	C-0025	TD400

1994-UP T444E MODEL 4700 3" FRONT PIPES

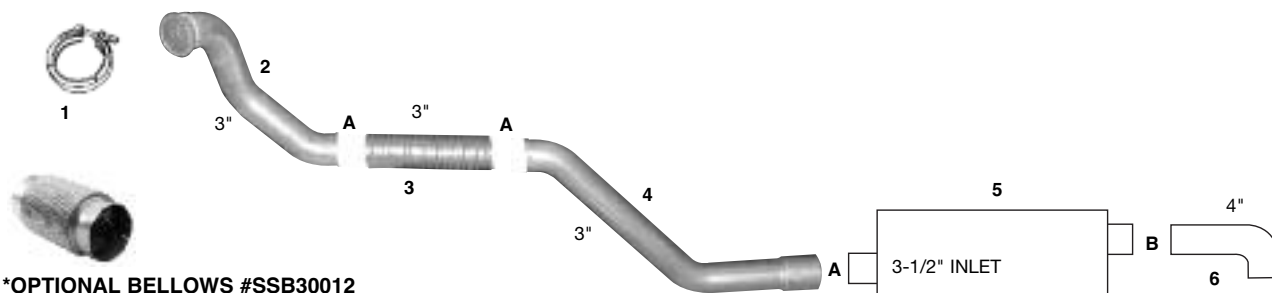

*OPTIONAL BELLOWS #SSB30012

1 - V-CLAMP	2 - TURBO PIPE	3 - FLEX	4 - FLEX TO MUFFLER PIPE	5 - MUFFLER	6 - TURN DOWN
AUTO-JET PART NUMBER					
T444VCL	T444T3MD	FLEX30012	T444FM3MD	C-0025	TD400
O.E. PART NUMBER					
3527500C1	3526527C1	758214C1	1678121C2	C-0025	TD400

ACCESSORIES

CLAMPS



MUFFLER HANGERS
SEE PAGE NAV 9

DESCRIPTION	A - 3-1/2"	B - 4"	C - 3"
FLAT	350SC	400SC	300SC
PRE-FORMED	350SCPF	400SCPF	300SCPF
U-BOLT	U-350	U-400	U-300

UNITED MUFFLER CORP.

U.S. toll free 1-800-247-5391 • Fax 515-224-0727 • website: www.auto-jet.com
Canada toll free 1-866-229-3402 • Fax 519-455-1103 • website: www.unitedmuffler.com

NAVISTAR INTERNATIONAL

1993-UP DT466, RD408 & 5304

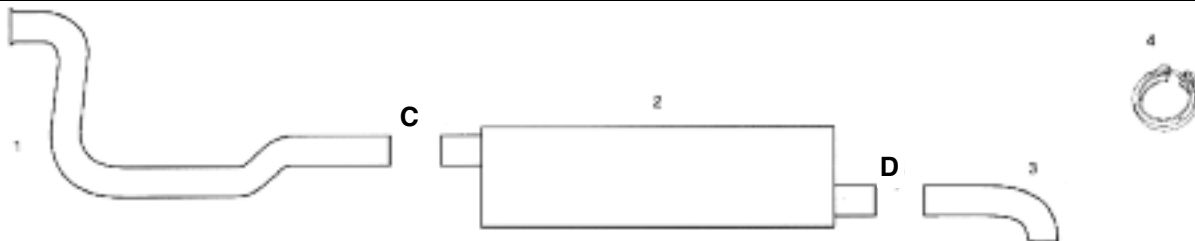

1 - TURBO PIPE	2 - MUFFLER	4 - TURN DOWN	V-CLAMP
466DTURBO93	C-0025	TD400	DT360VCL

1980-UP INTERNATIONAL 9.0 LITRE ENGINE

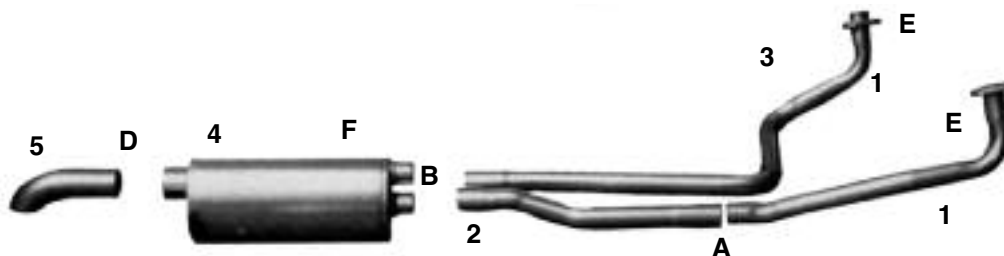

1 - RIGHT MANIFOLD	2 - RIGHT REAR MANIFOLD	3 - LEFT MANIFOLD	4 - MUFFLER	5 - TURN DOWN
482730C1	482726C1	482728C1	C-0040 or 2275400A	TD400

1983-UP INTERNATIONAL 6.9 LITRE, 7.3 LITRE

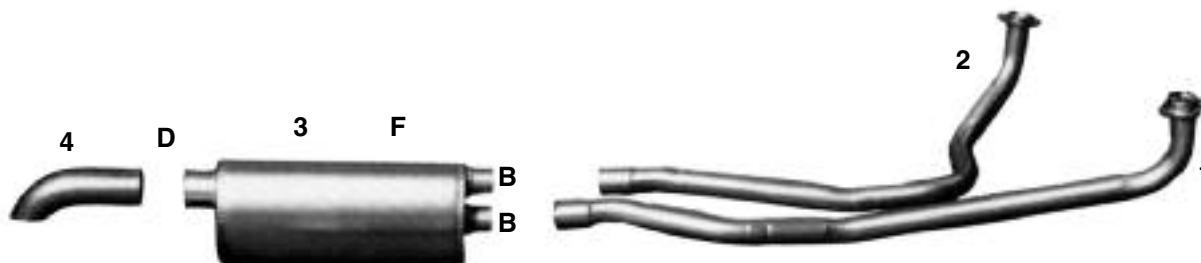

1 - RIGHT MANIFOLD	2 - LEFT MANIFOLD	3 - MUFFLER	4 - TURN DOWN
591595C2	1666966C2	C-0040 or 2275400A	TD400
--	NEW 7.3MPL (1988-UP)	--	--

ACCESSORIES

EXHAUST RING

MUFFLER HANGER

CLAMPS

E



9.0ER

F



OVALMHIH



A(2 1/2")

250SCPF

U-250

B(2 3/4")

275SCPF

U-275

C(3 1/2")

350SCPF

U-350

D(4")

400SCPF

U-400

UNITED MUFFLER CORP.

U.S. toll free 1-800-247-5391 • Fax 515-224-0727 • website: www.auto-jet.com
 Canada toll free 1-866-229-3402 • Fax 519-455-1103 • website: www.unitedmuffler.com

AUTO-JET PART NO.: C-0025
APPLICATION: DIESEL "POPULAR ON TRUCKS & SCHOOL BUSES"
ENGINE: T444E & DT-DTA-360 & 466 C.I.
YEAR: 1988 & UP

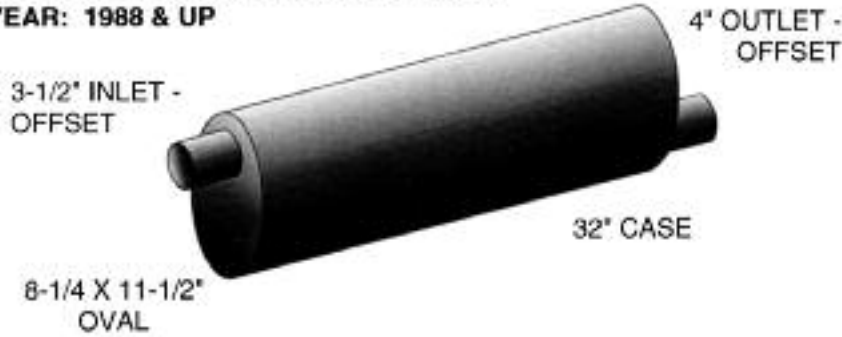

AUTO-JET PART NO.: C-0015
APPLICATION: DIESEL
ENGINE: DT-466
YEAR: 1979 TO 1987

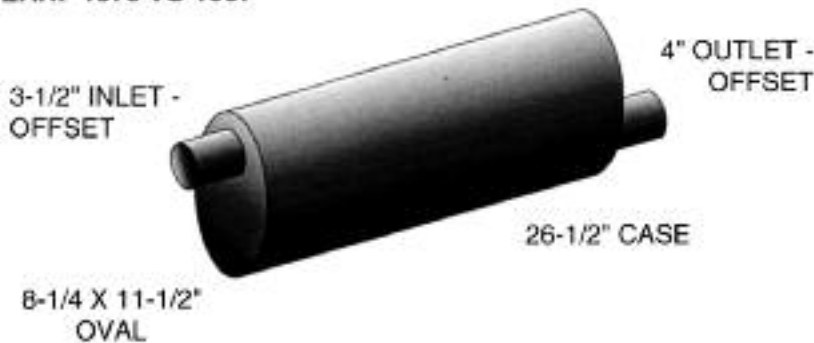

AUTO-JET PART NO.S:
C-0040 - HEAVY DUTY
2-275400A - ECONOMY
APPLICATION: DIESEL "POPULAR ON SCHOOL BUSES"
ENGINE: 9.0 - 7.3 - 6.9 & 3208 CAT.
YEAR: 1980 & UP

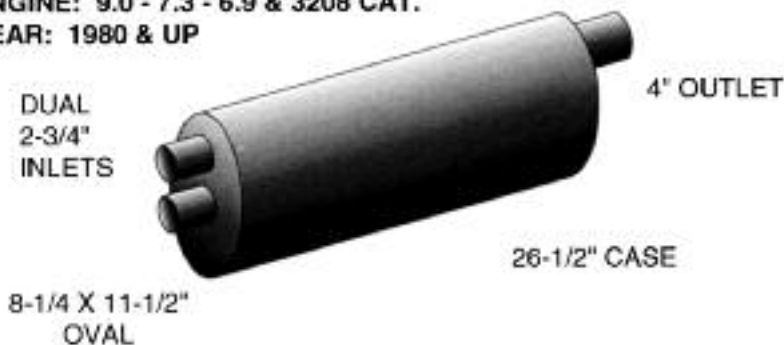

POPULAR NAVISTAR MUFFLER HANGERS

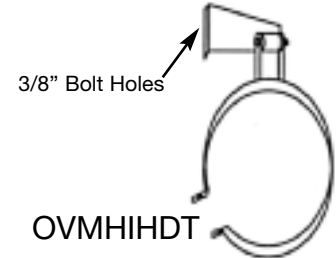

Engines: DT466-DT360-T444
 OE Cross Ref. # 1660540C91

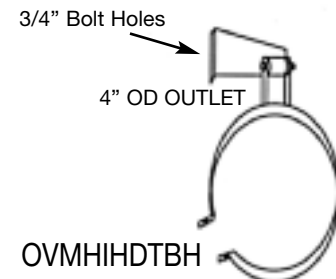

Engines: DT466-DT360-T444
 OE Cross Ref. # 2013206C91

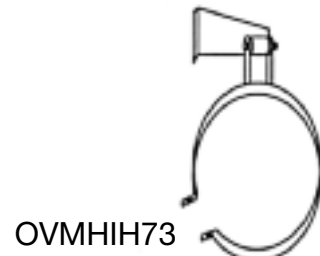

Engines: 7.3-6.9 Litre
 OE Cross Ref. # 1660543C91

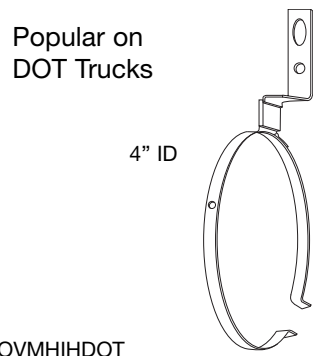

OE Cross Ref. # 1661881C96

NAVISTAR TRUCK MUFFLERS



END INLET - SIDE OUTLET 8-1/4" X 11-1/2" OVALS

AUTO-JET PART NO.: NAV-0005
SIDE OUTLET
Navistar Part No. OE 1669749C1
1669751C1

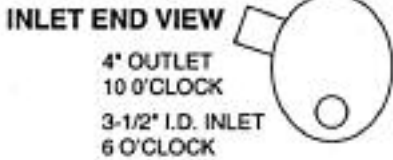

32" CASE
8-1/4 X 11-1/2" OVAL
7" FROM END OF CASE
TO CENTER OF OUTLET

FOR 6" SHORTER CASE
ORDER NAV-0040

POPULAR NAVISTAR MUFFLER HANGERS

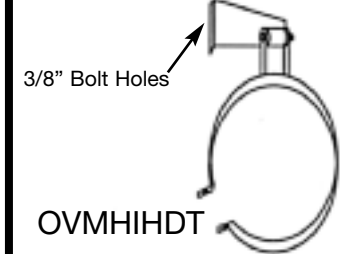

Engines: DT466-DT360-T444
OE Cross Ref. # 1660540C91

AUTO-JET PART NO.: NAV-0010
APPLICATION: DT 360 & DT 466
SIDE OUTLET
Navistar Part No. OE 1647999C1
New Navistar No. 1657433C1

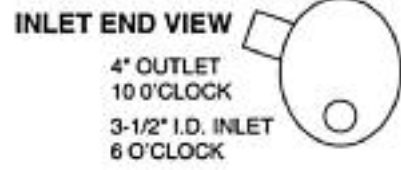

32" CASE
8-1/4 X 11-1/2" OVAL
12" FROM END OF CASE
TO CENTER OF OUTLET

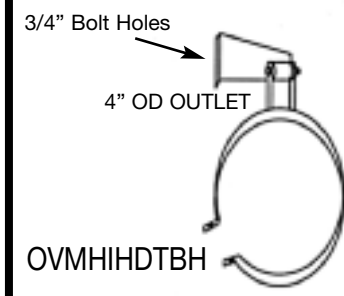

Engines: DT466-DT360-T444
OE Cross Ref. # 2013206C91

AUTO-JET PART NO.: NAV-0015
APPLICATION: DT 360 & DT 466
SIDE OUTLET
Navistar Part No. OE 1648000C1

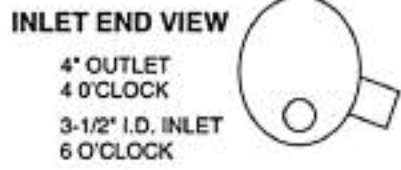

32" CASE
8-1/4 X 11-1/2" OVAL
12" FROM END OF CASE
TO CENTER OF OUTLET

FOR 6" SHORTER CASE
ORDER NAV-0040

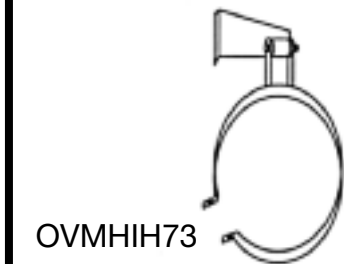

Engines: 7.3-6.9 Litre
OE Cross Ref. # 1660543C91

END INLET AND OUTLET ON SAME END REVERSE FLOW

AUTO-JET PART NO.: NAV-0020
END INLET - END OUTLET
SAME END - REVERSE FLOW

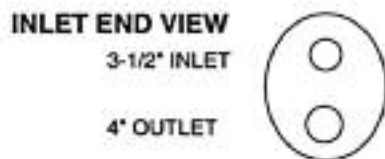

32" CASE
8-1/4 X 11-1/2" OVAL

for 27" case order c-0050

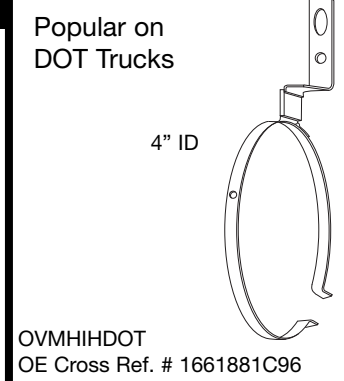

UNITED MUFFLER CORP.

U.S. toll free 1-800-247-5391 • Fax 515-224-0727 • website: www.auto-jet.com
Canada toll free 1-866-229-3402 • Fax 519-455-1103 • website: www.unitedmuffler.com



NAVISTAR EXHAUST COMPONENTS

8-1/4" X 11-1/2" OVALS

AUTO-JET PART NO.: NAV-0025
APPLICATION: DT360 & DT466
ESPECIALLY FOR HIGHWAY DEPT. TRUCKS
5" SHORTER CASE THAN O.E. 1664453C2

For Muffler Hangers
See Page MUFF 10

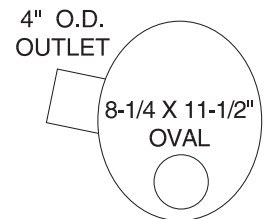
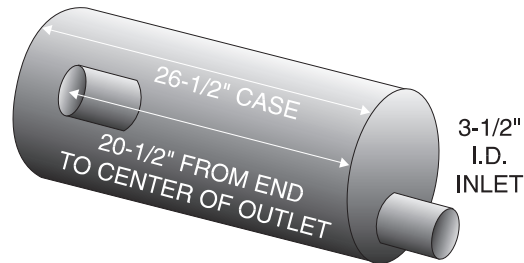

INLET END VIEW

AUTO-JET PART NO.: NAV-0030 HEAVY DUTY MUFFLER
86754M ECONOMY MUFFLER

APPLICATION: DT360 & DT466
 Navistar Part No.: O.E. 1664453C2

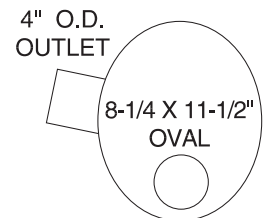

INLET END VIEW

AUTO-JET PART NO.: NAV-0035
END INLET - SIDE OUTLET
NAVISTAR PART NO. 578 070 C1

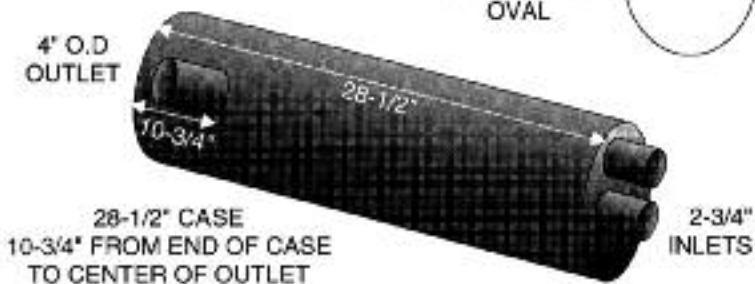

INLET END VIEW



AUTO-JET PART NO.: NAV-0040
6" SHORTER CASE THAN NAV-0005

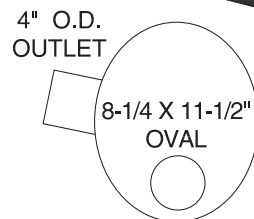
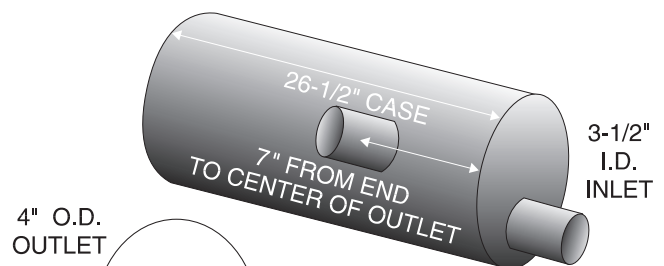

INLET END VIEW

UNITED MUFFLER CORP.

U.S. toll free 1-800-247-5391 • Fax 515-224-0727 • website: www.auto-jet.com
 Canada toll free 1-866-229-3402 • Fax 519-455-1103 • website: www.unitedmuffler.com

NAVISTAR

END INLET - END OUTLET

AUTO-JET PART NO.S:
C-0030 - HEAVY DUTY
END INLET - SIDE OUTLET
 Navistar Part No. 508 894 C1
 New Navistar No. 1657433C1

INLET END VIEW

8-1/4 X 11-1/2"
 OVAL



OUTLET END VIEW

4" O.D. OUTLET



8-1/2" X 11-1/2" OVAL

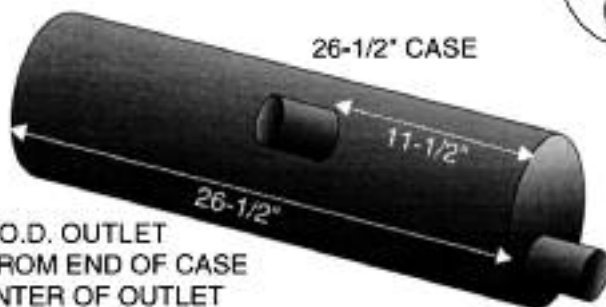

4" O.D. OUTLET
 11-1/2" FROM END OF CASE
 TO CENTER OF OUTLET

3-1/2"
 INLET

26-1/2" CASE

11-1/2"

26-1/2"

INTERNATIONAL ACCESSORIES



NOTE: International reference numbers are for identification purposes only.

DESCRIPTION	TURN SIGNAL	INGINTION		RESERVOIR - 1/2 GAL. W/ PUMP & CAP	HEADLIGHT
PART #	NAVTSW	NAVIGNSWS	NAVIGNSW	NAVWWR1	NAVHLSW
INT'L REF. #	417302C94	1652306C91	468438C91	394120C91	393442C1
DESCRIPTION	DIMMER SWITCHES			-	RADIATOR SURGE TANK
	3800	S-MODEL	LOADSTAR		
PART #	NAVDIM38	NAVDIMS	NAVDIM	-	NAVSURGE
INT'L REF. #	1661899C91	452187C1	594189C1	-	1619114C5

UNITED MUFFLER CORP.

U.S. toll free 1-800-247-5391 • Fax 515-224-0727 • website: www.auto-jet.com
 Canada toll free 1-866-229-3402 • Fax 519-455-1103 • website: www.unitedmuffler.com

NAV 8

AUTO-JET PART NO.: 85-0040
APPLICATION: GAS
ENGINE: 392 C.I. & 345 C.I.
YEAR: 1979 TO 1987

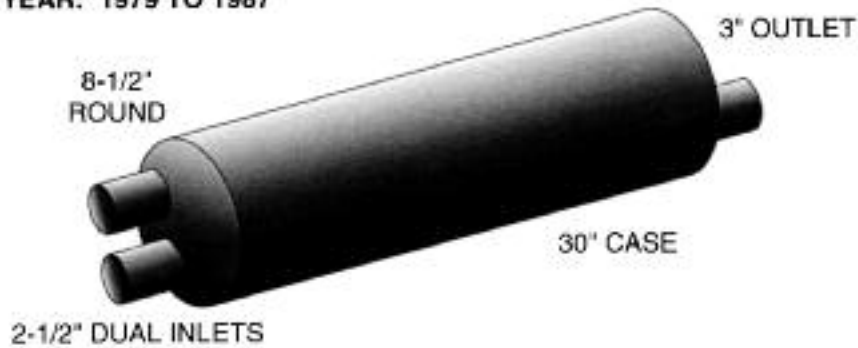

MUFFLER HANGER



#850MH

AUTO-JET PART NO.: 85-0075
APPLICATION: GAS
ENGINE: 404 C.I.
YEAR: 1979 TO 1987

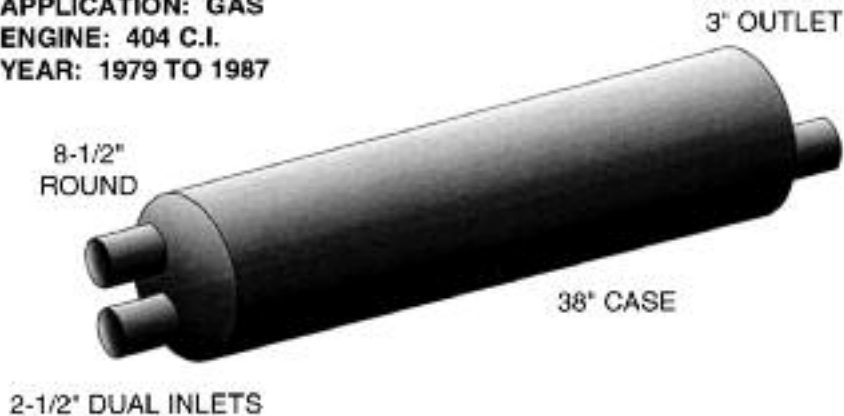

MUFFLER HANGER



#850MH

AUTO-JET PART NO.: 85-0015
APPLICATION: GAS
ENGINE: 404 C.I., 392 C.I., 345 C.I.
YEAR: 1972 TO 1978

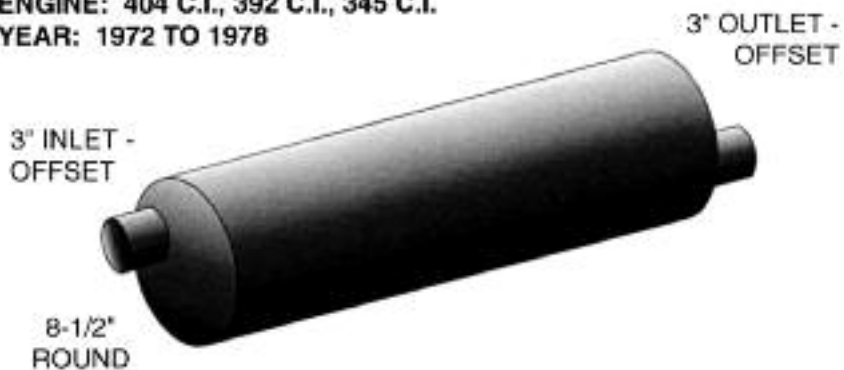

MUFFLER HANGER



#850MH

UNITED MUFFLER CORP.

U.S. toll free 1-800-247-5391 • Fax 515-224-0727 • website: www.auto-jet.com
 Canada toll free 1-866-229-3402 • Fax 519-455-1103 • website: www.unitedmuffler.com

United #	NAVISTAR #
466DTLE20	3554832C1
NAVEXT20	2006821C1
350400L	1647998C1
96690L	587519C2
466T89	1684397C1
466T93	2004504C1
466TDOT93	2005354C1
96790L	587521C2
T444T35MD	2033702C1
FLEX35012	753329C1
T444FM35MD	2033703C1
T444VCL	3527500C1
T444T3MD	3526527C1
FLEX30012	758214C1
T444FM3MD	1678121C2
466DTURBO93	2004557C1
360DT90	1684397C1
360DT90EXT	1686802C1
360DTLE	1616314C1
466DTLE	1621340C1
360DTLEXT	1616315C1
360DTURBO	1668838C1
360DTURBRH	1614955C1
90RMP	482730C1
900RRMP	482726C1
90LMP	482728C1
69MPR	591595C2
73MPL	1666966C2
OVMHIHDT	1660540C91
OVMHIHDTBH	2013206C1
OVMHIH73	1660543C91
OVMHIHDOT	1661881C96
NAV-0005	1669749C1
NAV-0005	1669751C1
NAV-0010	1647999C1

UNITED MUFFLER CORP.

U.S. toll free 1-800-247-5391 • Fax 515-224-0727 • website: www.auto-jet.com
Canada toll free 1-866-229-3402 • Fax 519-455-1103 • website: www.unitedmuffler.com

NAV 10

NAV-0010	1657466C1
NAV-0015	1648000C1
NAV-0030	1664453C2
NAV-0035	578070C1
C-0030	508894C1
C-0030	1657433C1
NAVSURGE	1619114C5

UNITED MUFFLER CORP.

U.S. toll free 1-800-247-5391 • Fax 515-224-0727 • website: www.auto-jet.com
Canada toll free 1-866-229-3402 • Fax 519-455-1103 • website: www.unitedmuffler.com

NAV 11

OFF-ROAD EQUIPMENT MUFFLERS



Nationwide toll free 1-866-229-3402

Fax 519-455-1103 • website: www.unitedmuffler.com

OFF-ROAD EQUIPMENT MUFFLERS



CATERPILLAR

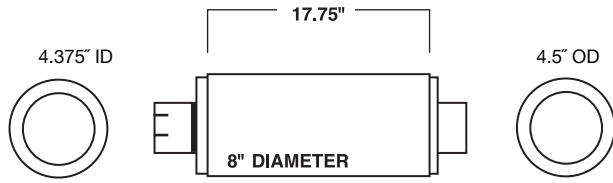

MODEL: CAT D4

IP0408

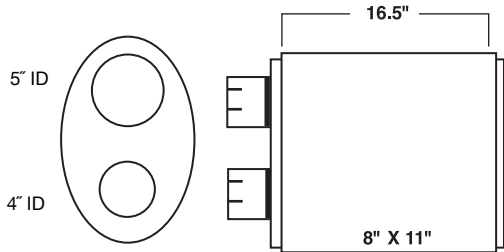

MODEL: CAT 215

6N3964
OR
1W2572

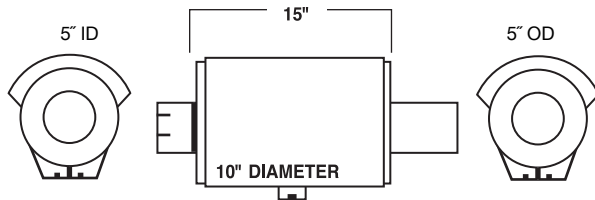

MODEL: CAT D7H

1W9229

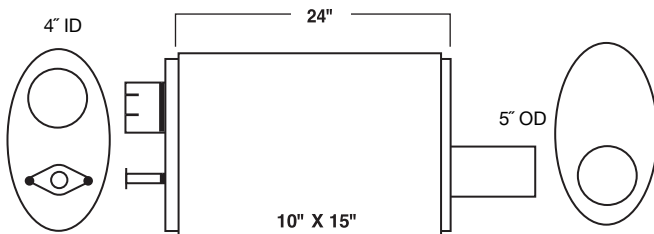

MODEL: CAT 631D

2P5609

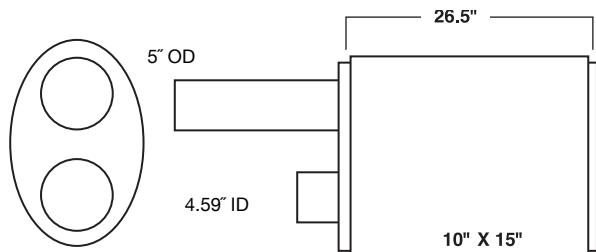

MODEL: CAT 235

2W3428

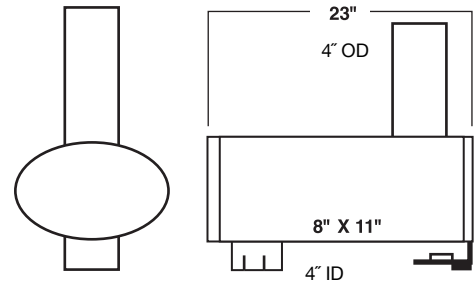

MODEL: CAT D5H

2W3597

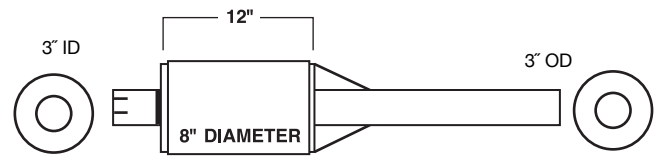

MODEL: CAT 930B DOZER

3K3124

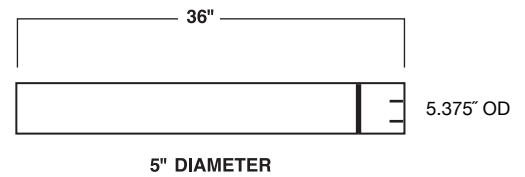

MODEL: D5H STACK

3W7770

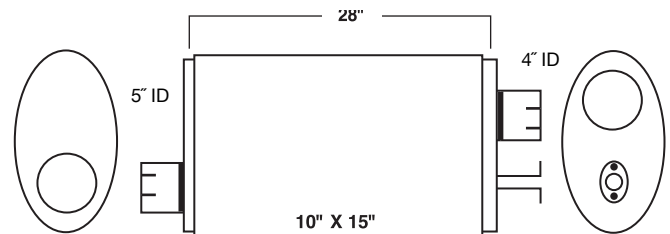

MODEL: CAT 130G

4N8942

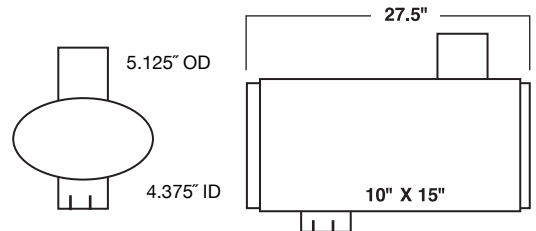

MODEL: CAT 235

4W3632

Caterpillar Part Numbers are for reference use only.

UNITED MUFFLER CORP.

U.S. toll free 1-800-247-5391 • Fax 515-224-0727 • website: www.auto-jet.com
 Canada toll free 1-866-229-3402 • Fax 519-455-1103 • website: www.unitedmuffler.com

OR 1



OFF-ROAD EQUIPMENT MUFFLERS

CATERPILLAR

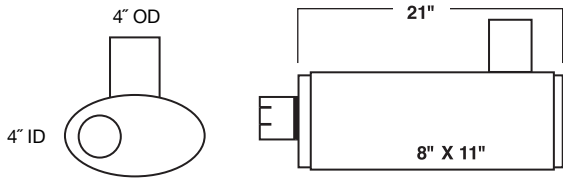

MODEL: CAT 215 EXCAVATOR 6C0482

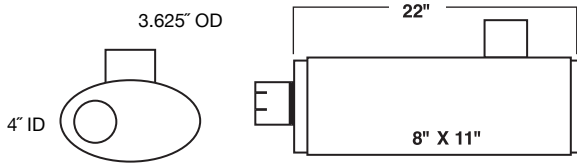

(ALSO ON PAGE OR10)
MODEL: CAT 215 EXCAVATOR 6C2104

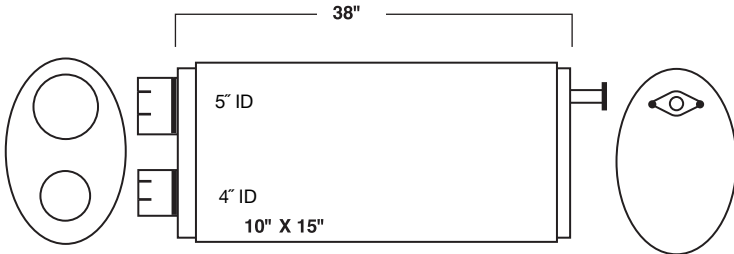

MODEL: CAT 627B 6N4183

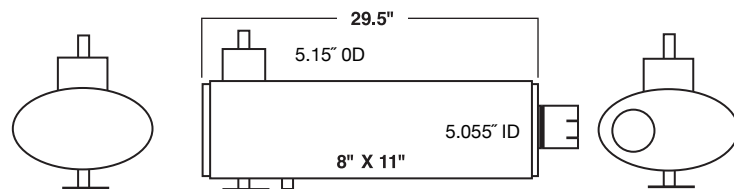

MODEL: CAT D8K 6N5437

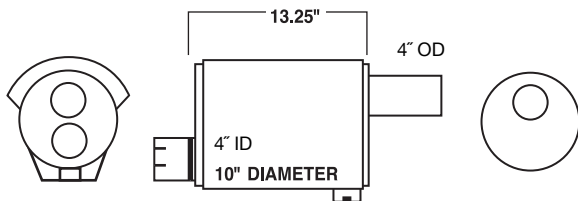

MODEL: CAT D6H 7E3683

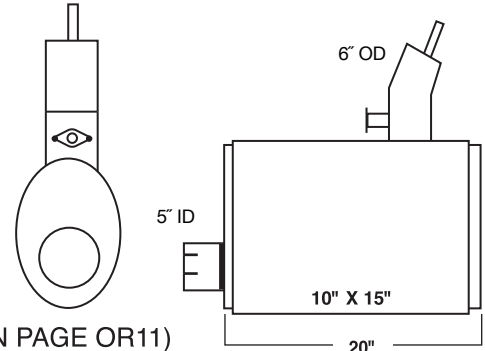

(ALSO ON PAGE OR11)
MODEL: CAT 980 LOADER 7N1393

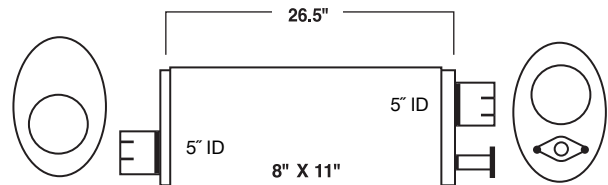

MODEL: CAT 980B, 330JB 7N3235

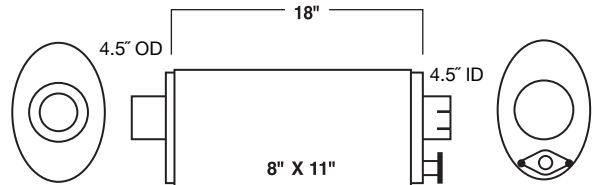

MODEL: NOT AVAILABLE 7N8117

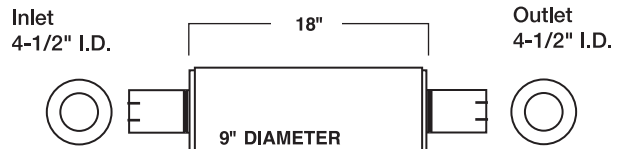

MODEL: CAT 977 LOADER 7S6741

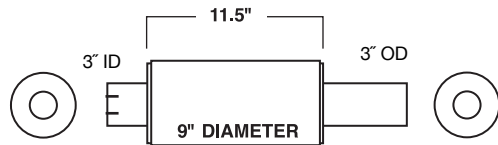

MODEL: CAT 977 LOADER 7S8301

Caterpillar Part Numbers are for reference use only.

UNITED MUFFLER CORP.

U.S. toll free 1-800-247-5391 • Fax 515-224-0727 • website: www.auto-jet.com
Canada toll free 1-866-229-3402 • Fax 519-455-1103 • website: www.unitedmuffler.com

OFF-ROAD EQUIPMENT MUFFLERS



CATERPILLAR

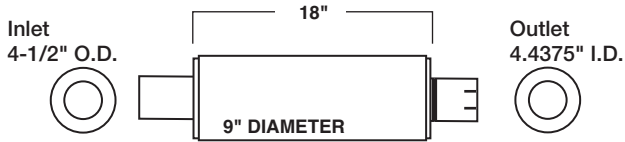

MODEL: CAT 966 LOADER 7S8443

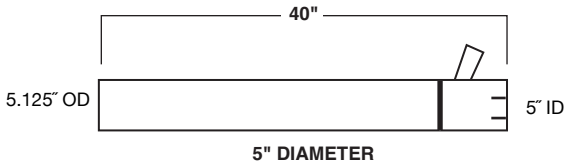

MODEL: CAT D7H STACK 7W5837

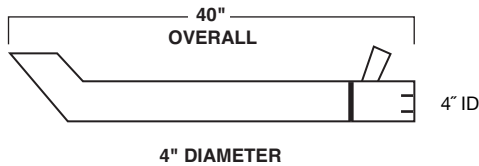

MODEL: CAT D6H STACK 7W5838

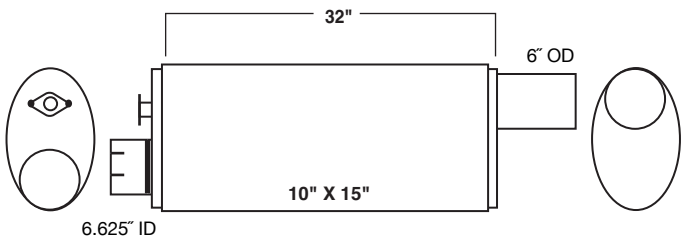

MODEL: CAT 631C SCRAPER 9S7786

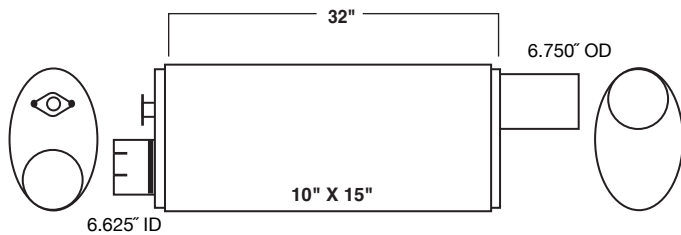

MODEL: CAT 631C SCRAPER 9S7787

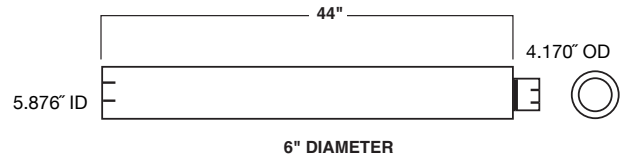

MODEL: CAT 968C, 14E, 140G 8S0905

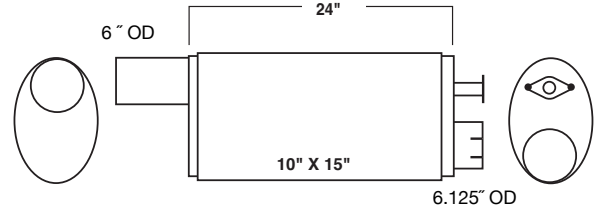

MODEL: CAT D9G 8S5438

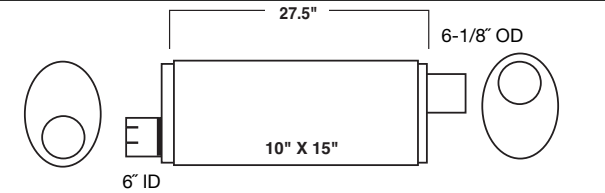

MODEL: CAT 988, 824B, 826B 8S6443

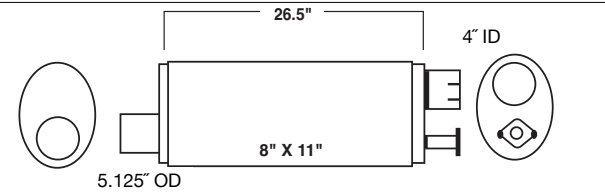

MODEL: CAT 927B 9S7079

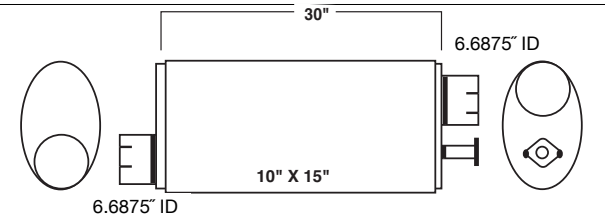

MODEL: CAT 988B 7W8445

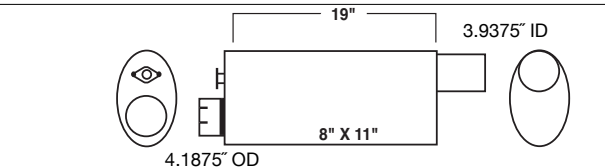

MODEL: CAT 140G 8N5565

Caterpillar Part Numbers are for reference use only.

UNITED MUFFLER CORP.

U.S. toll free 1-800-247-5391 • Fax 515-224-0727 • website: www.auto-jet.com
 Canada toll free 1-866-229-3402 • Fax 519-455-1103 • website: www.unitedmuffler.com



OFF-ROAD EQUIPMENT MUFFLERS

CATERPILLAR

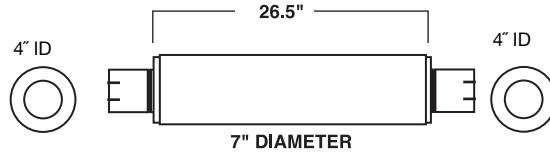

MODEL: CAT 627B 9S8069

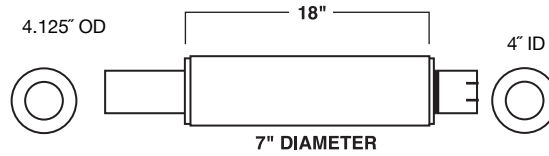

MODEL: CAT 518 9S9328

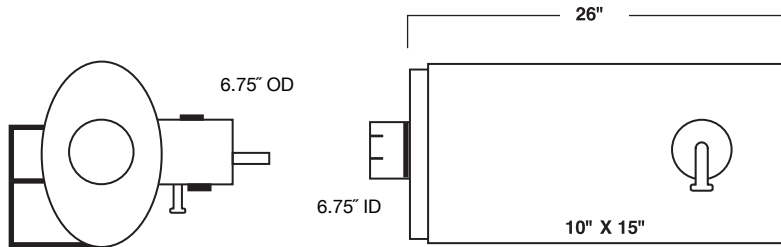

MODEL: 988F 4P2496

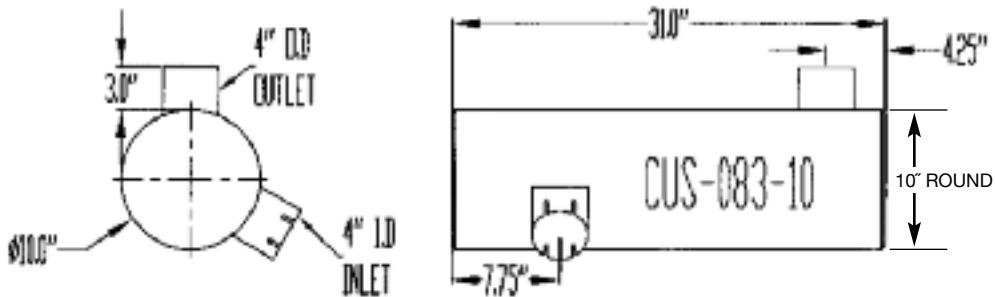

MODEL: CAT EL240B

Caterpillar Part Numbers are for reference use only.

UNITED MUFFLER CORP.

U.S. toll free 1-800-247-5391 • Fax 515-224-0727 • website: www.auto-jet.com
Canada toll free 1-866-229-3402 • Fax 519-455-1103 • website: www.unitedmuffler.com

OR 4

OFF-ROAD EQUIPMENT MUFFLERS



CATERPILLAR

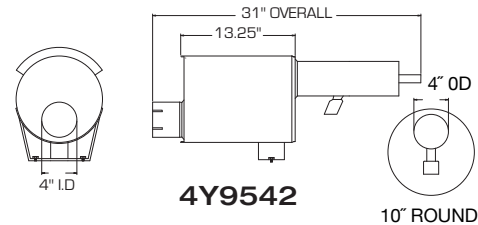
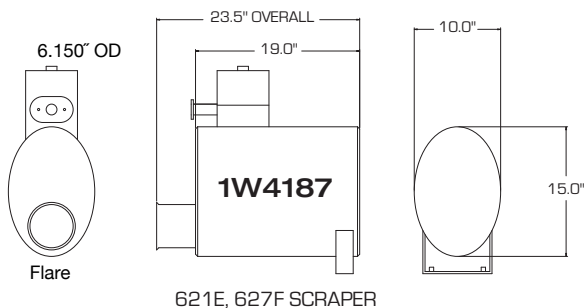
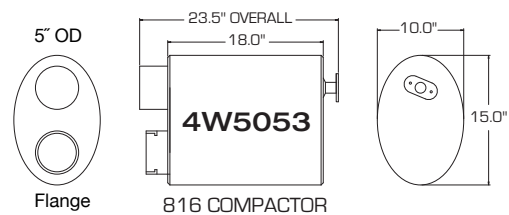
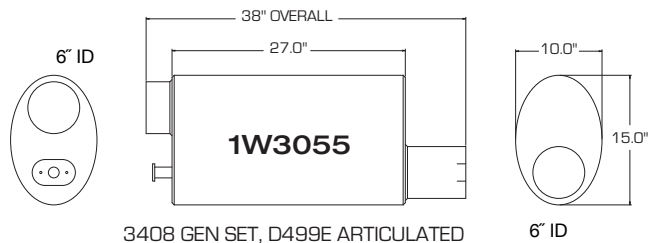
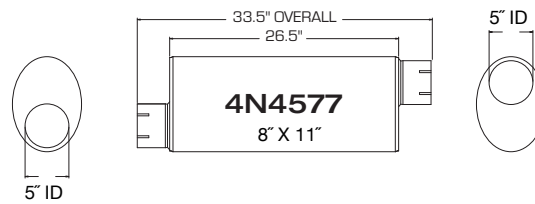
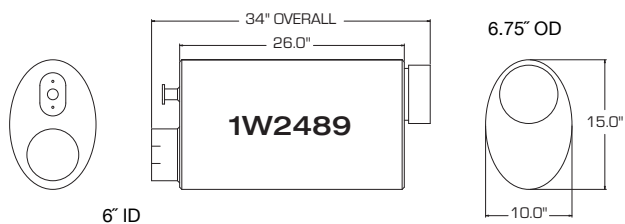
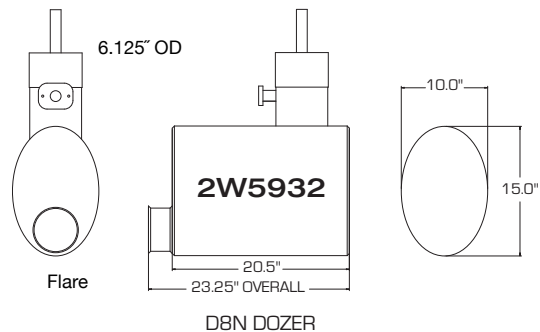
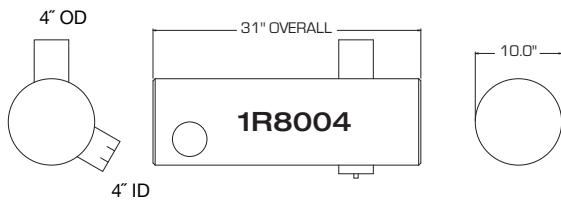

UNITED MUFFLER CORP.

U.S. toll free 1-800-247-5391 • Fax 515-224-0727 • website: www.auto-jet.com
 Canada toll free 1-866-229-3402 • Fax 519-455-1103 • website: www.unitedmuffler.com



OFF-ROAD EQUIPMENT MUFFLERS

CATERPILLAR



4Y2817

D6H, D6R DOZERS

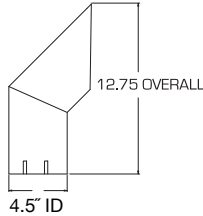

7Y1315

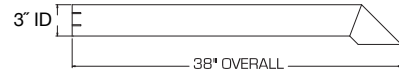

7C2991

5.125" OD



Flange

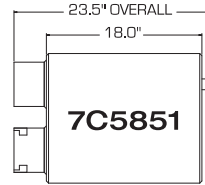

7C5851

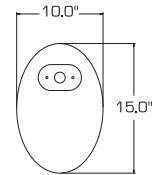

5.125" OD

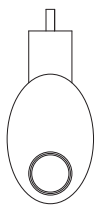

Flange

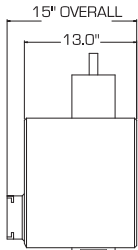

6N0731

D7G DOZER

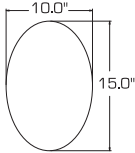

Flare



7N2321

953 TRACK LOADER

3.5" ID



4.5" OD



4" ID

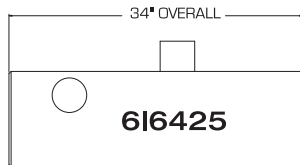

6I6425



4" OD

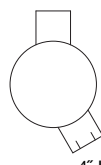

4" ID

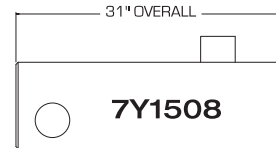

7Y1508

322, 325 EXCAVATORS

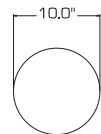

UNITED MUFFLER CORP.

U.S. toll free 1-800-247-5391 • Fax 515-224-0727 • website: www.auto-jet.com
 Canada toll free 1-866-229-3402 • Fax 519-455-1103 • website: www.unitedmuffler.com

OFF-ROAD EQUIPMENT MUFFLERS



CATERPILLAR

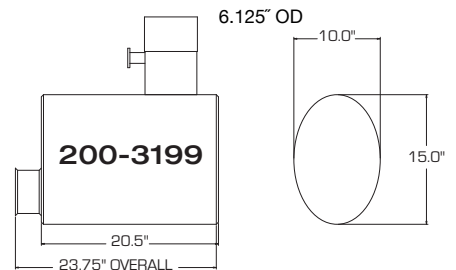
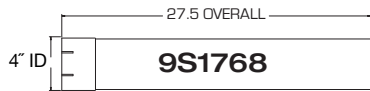

D8N, D8R DOZERS

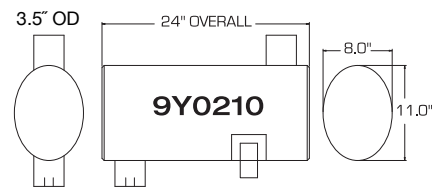

MODEL : 938F WHEEL LOADER

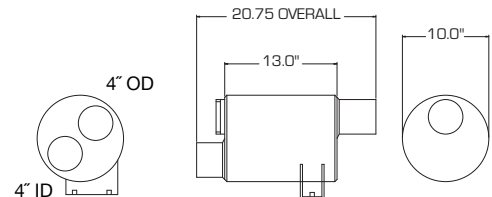

D6R DOZER

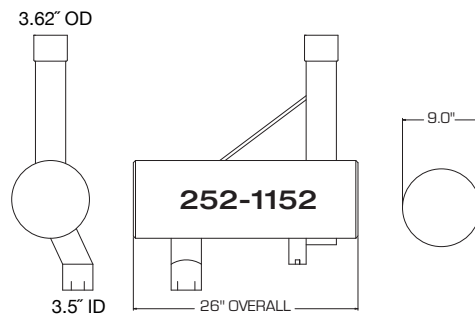
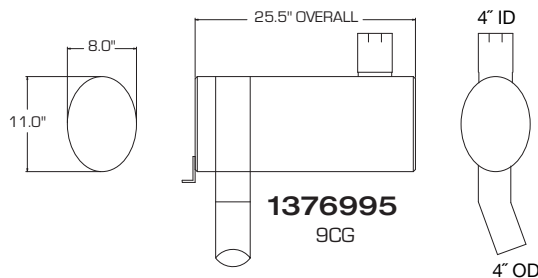

Model : D6M CAT

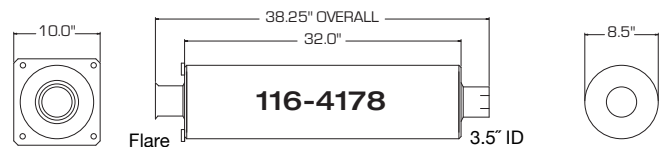
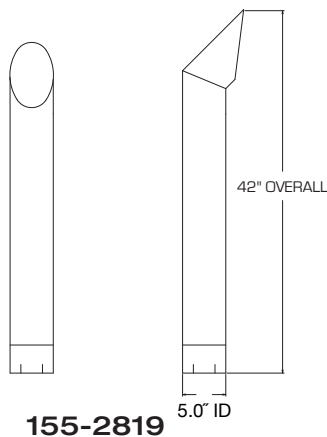

UNITED MUFFLER CORP.

U.S. toll free 1-800-247-5391 • Fax 515-224-0727 • website: www.auto-jet.com
 Canada toll free 1-866-229-3402 • Fax 519-455-1103 • website: www.unitedmuffler.com



OFF-ROAD EQUIPMENT MUFFLERS

CATERPILLAR

THE FOLLOWING ADDITIONAL CATERPILLAR REPLACEMENT MUFFLERS ARE AVAILABLE:

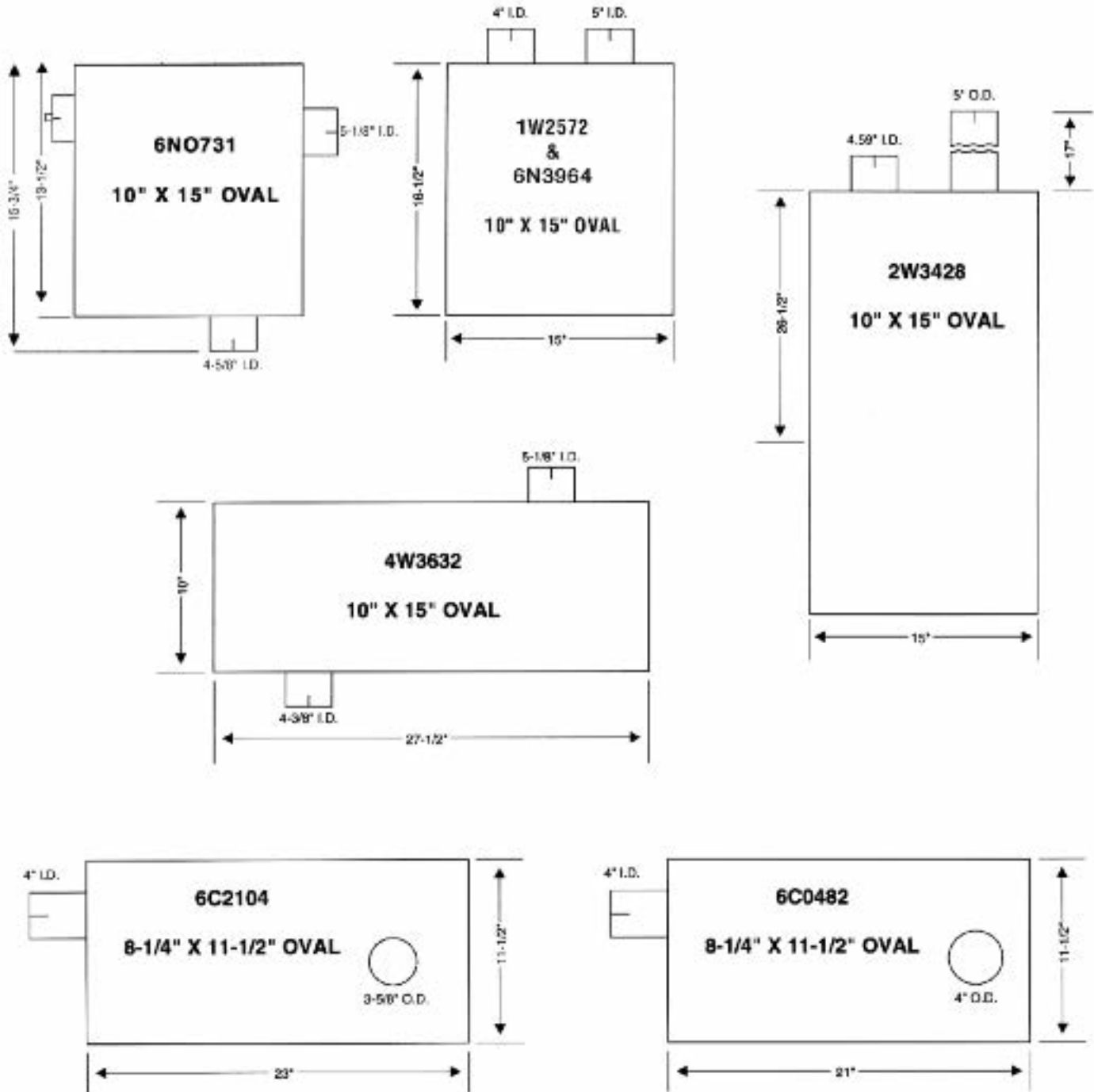

Caterpillar Part Numbers are for reference use only.

UNITED MUFFLER CORP.

U.S. toll free 1-800-247-5391 • Fax 515-224-0727 • website: www.auto-jet.com
Canada toll free 1-866-229-3402 • Fax 519-455-1103 • website: www.unitedmuffler.com

OR 8

OFF-ROAD EQUIPMENT MUFFLERS



CATERPILLAR

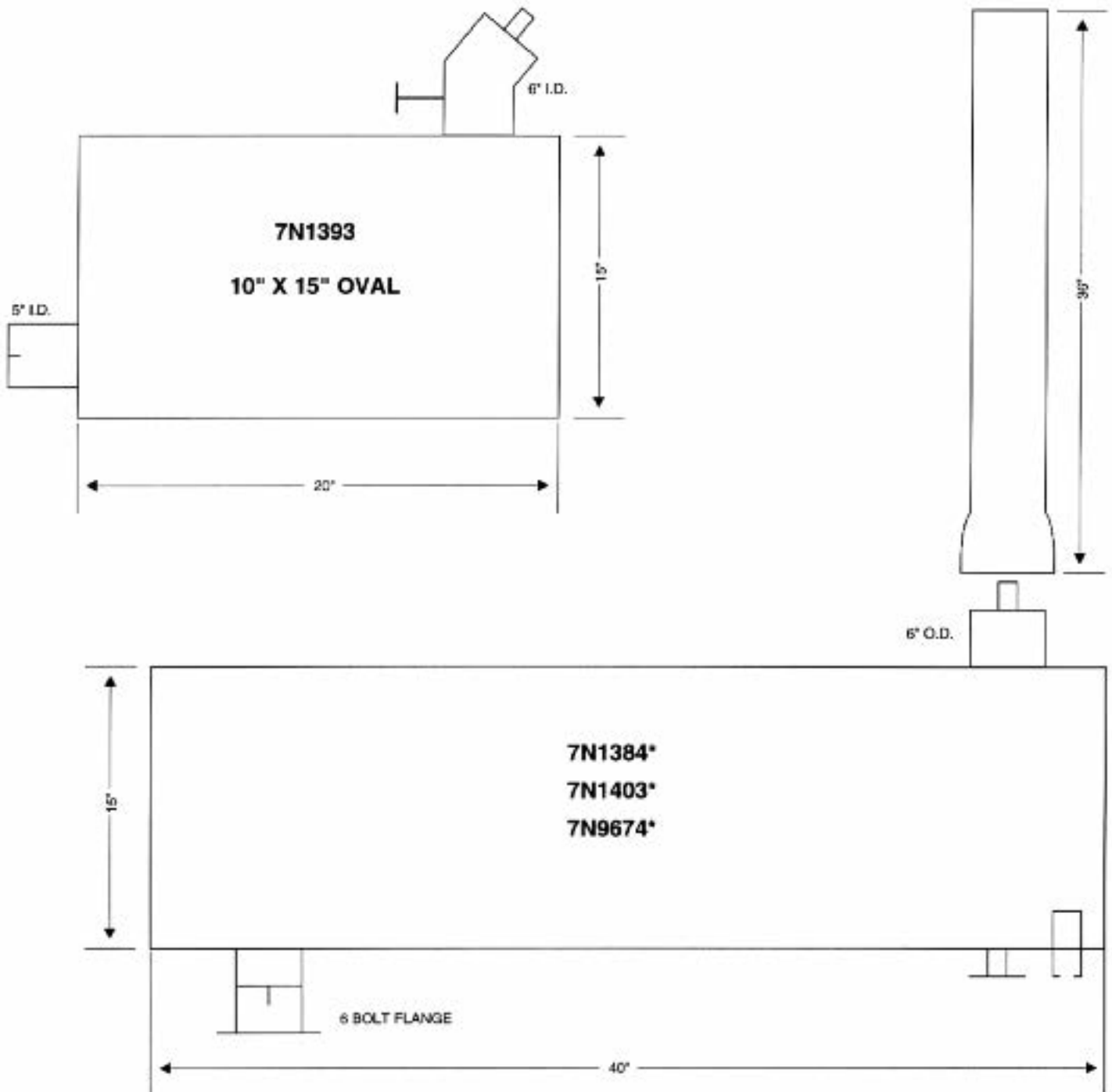

*** DIFFERENT THAN ORIGINAL, BUT IS DIRECT FIT AND INCLUDES EJECTOR STACK AND CLAMPS**

Caterpillar Part Numbers are for reference use only.

UNITED MUFFLER CORP.

U.S. toll free 1-800-247-5391 • Fax 515-224-0727 • website: www.auto-jet.com
Canada toll free 1-866-229-3402 • Fax 519-455-1103 • website: www.unitedmuffler.com

OR 9



OFF-ROAD EQUIPMENT MUFFLERS

CASE

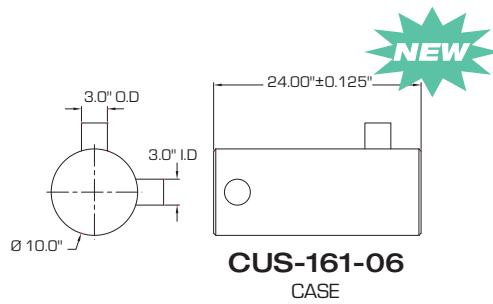
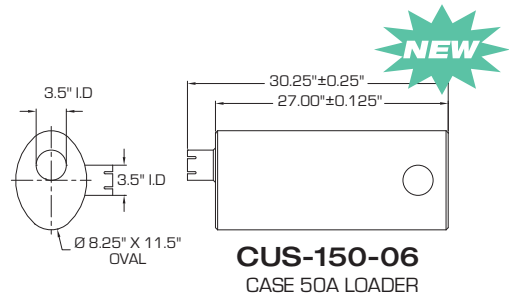
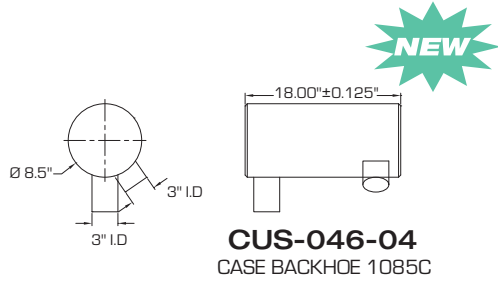

DRESSER

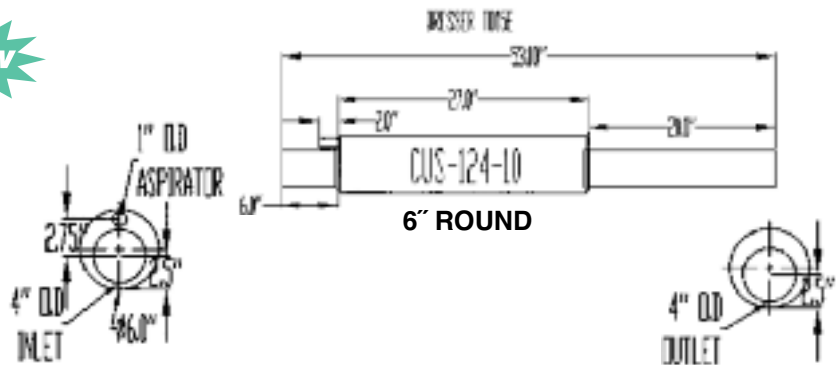
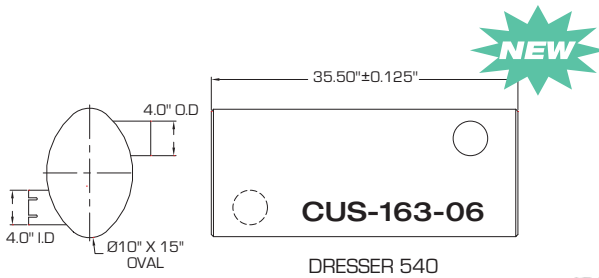
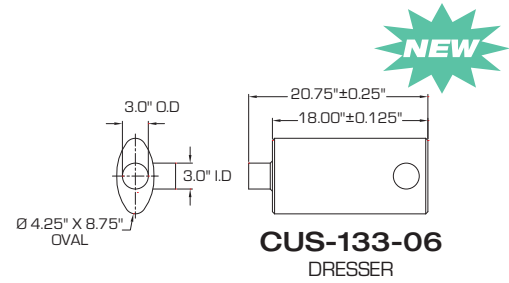
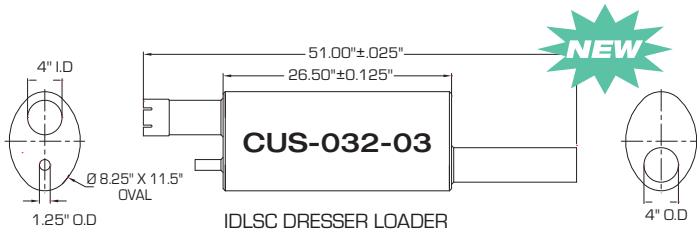

UNITED MUFFLER CORP.

U.S. toll free 1-800-247-5391 • Fax 515-224-0727 • website: www.auto-jet.com
Canada toll free 1-866-229-3402 • Fax 519-455-1103 • website: www.unitedmuffler.com

OR 10

OFF-ROAD EQUIPMENT MUFFLERS



GENERAL MOTORS

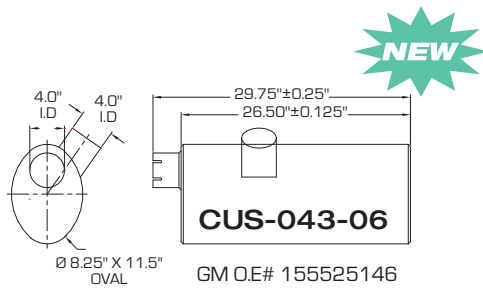

HITACHI

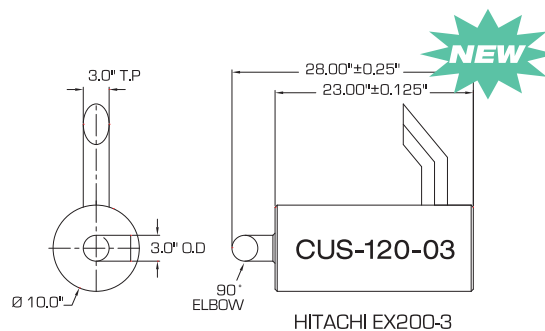
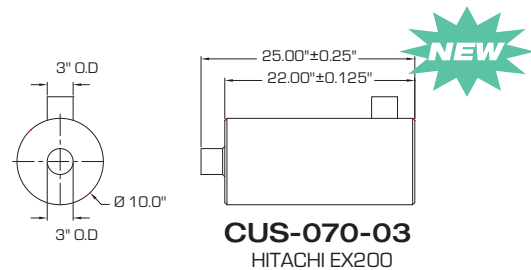
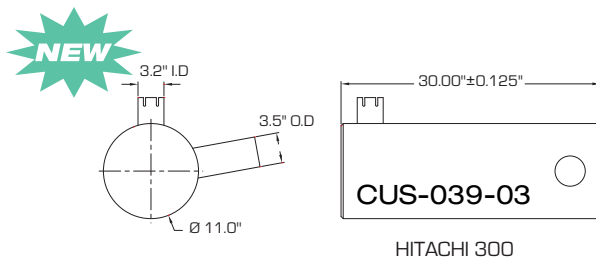
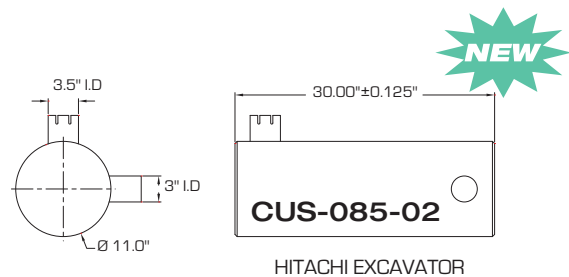
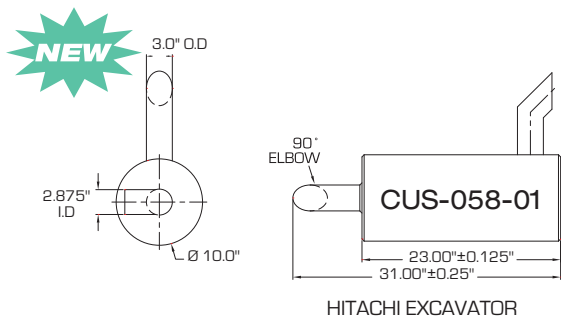

UNITED MUFFLER CORP.

U.S. toll free 1-800-247-5391 • Fax 515-224-0727 • website: www.auto-jet.com
Canada toll free 1-866-229-3402 • Fax 519-455-1103 • website: www.unitedmuffler.com



OFF-ROAD EQUIPMENT MUFFLERS

INTERNATIONAL

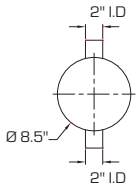

CUS-114-01
INTERNATIONAL BACKHOE

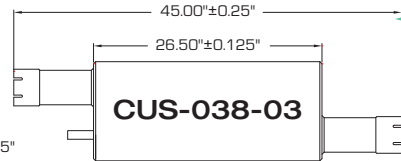

CUS-038-03
INTERNATIONAL 1175 END LOADER O.E# 680690

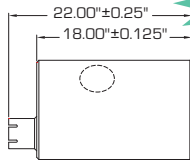
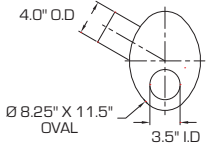
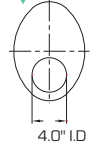

CUS-020-04
2001 INTERNATIONAL 4900

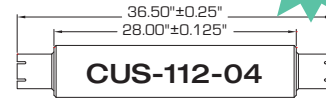
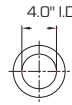

CUS-112-04
1990 INTERNATIONAL 4900

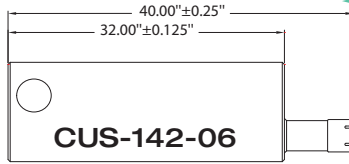
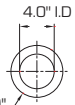

CUS-142-06
2004 INTERNATIONAL (O.E# 3545527C1)

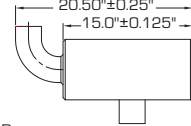
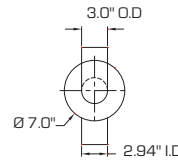
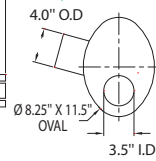

CUS-009-07
JLG 15 HAX



JOHN DEERE

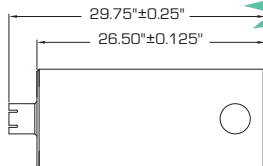
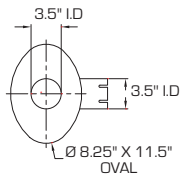

CUS-050-01
JOHN DEERE 4 CYLINDER

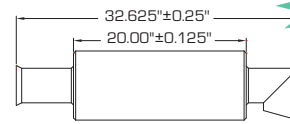

CUS-074-01
JOHN DEERE GRADER 670A

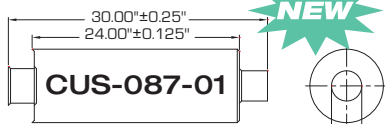
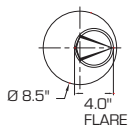
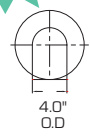

CUS-087-01
JOHN DEERE

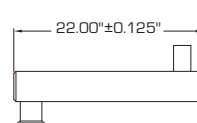
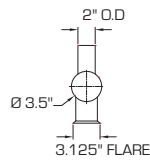

CUS-093-01
JOHN DEERE 450 CRAWLER LOADER



UNITED MUFFLER CORP.

U.S. toll free 1-800-247-5391 • Fax 515-224-0727 • website: www.auto-jet.com
Canada toll free 1-866-229-3402 • Fax 519-455-1103 • website: www.unitedmuffler.com

OFF-ROAD EQUIPMENT MUFFLERS



JOHN DEERE

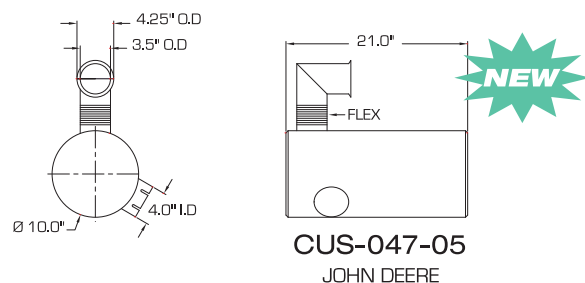
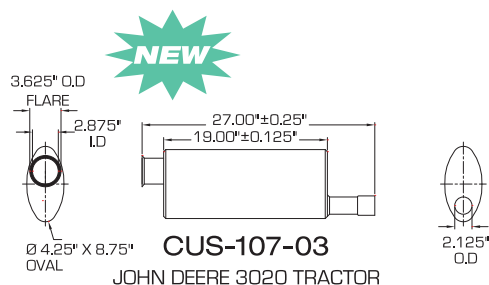
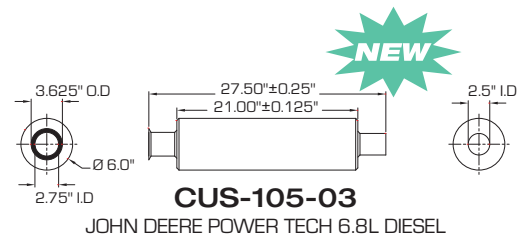
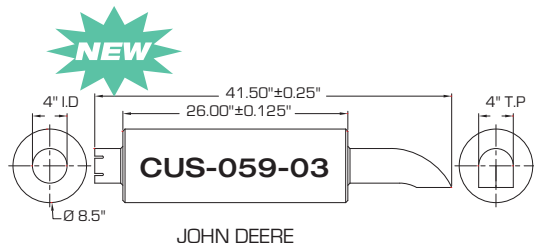
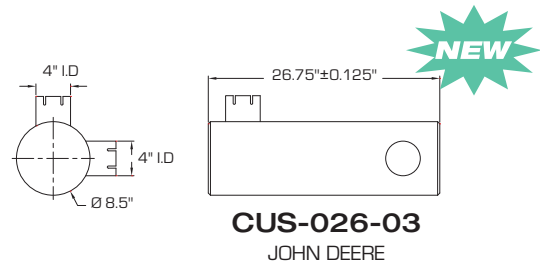
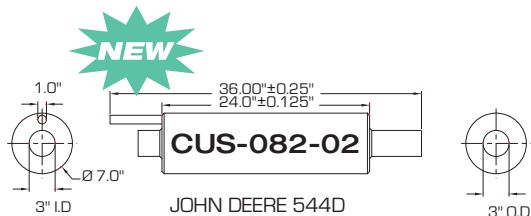
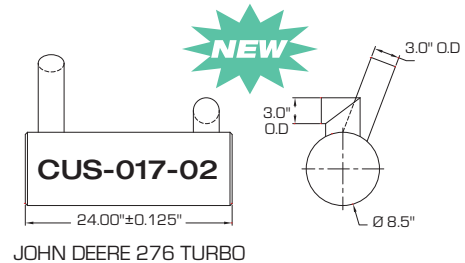
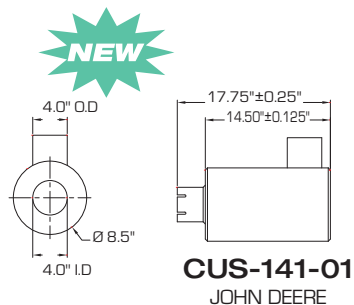
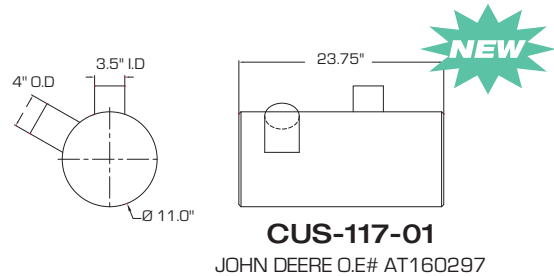
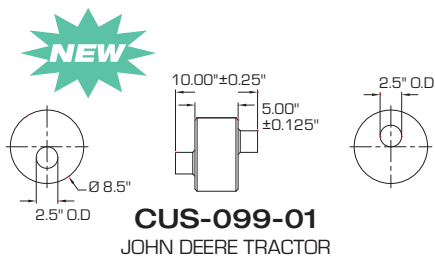

UNITED MUFFLER CORP.

U.S. toll free 1-800-247-5391 • Fax 515-224-0727 • website: www.auto-jet.com
Canada toll free 1-866-229-3402 • Fax 519-455-1103 • website: www.unitedmuffler.com



OFF-ROAD EQUIPMENT MUFFLERS

JOHN DEERE

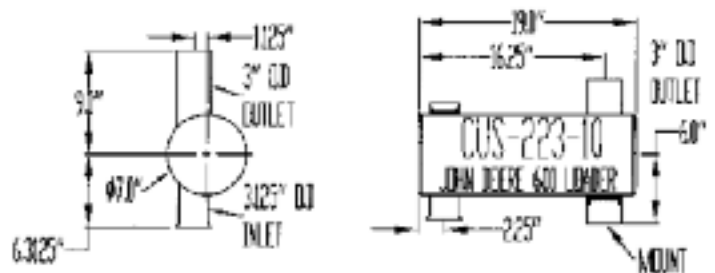
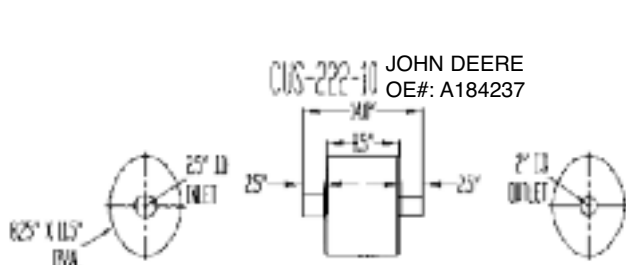
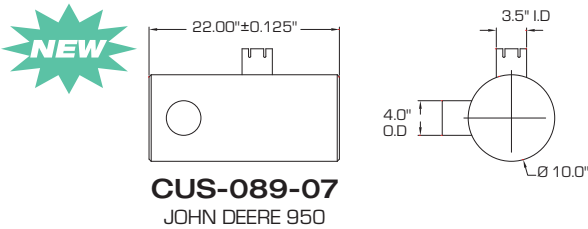
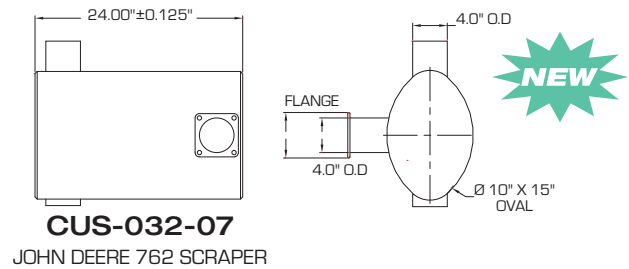
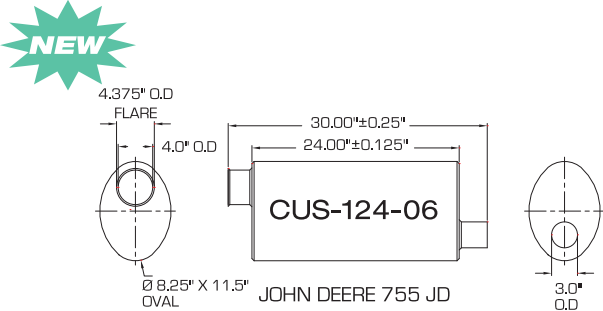
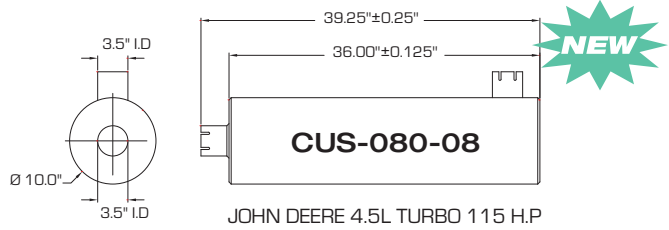
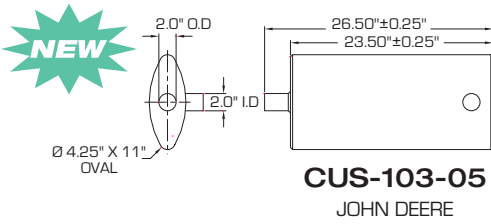

KOBELCO

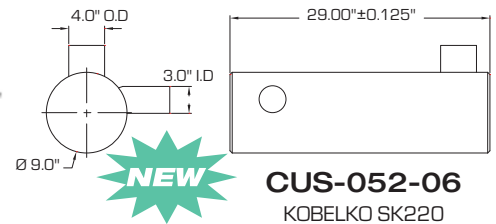
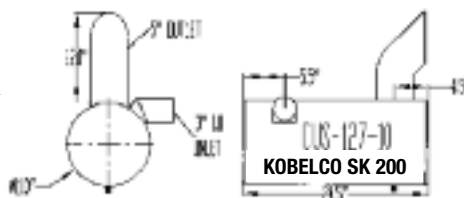
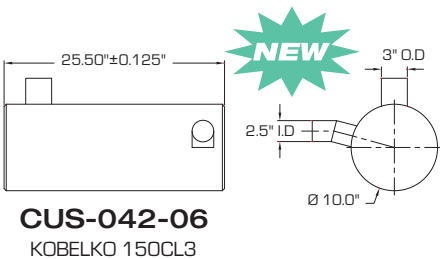

UNITED MUFFLER CORP.

U.S. toll free 1-800-247-5391 • Fax 515-224-0727 • website: www.auto-jet.com
Canada toll free 1-866-229-3402 • Fax 519-455-1103 • website: www.unitedmuffler.com

OFF-ROAD EQUIPMENT MUFFLERS



KOMATSU

MITSUBISHI

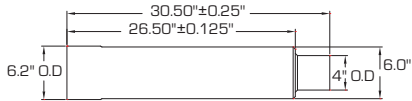

CUS-031-03
KOMATSU 150 H.P.

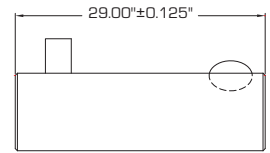
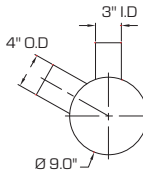

CUS-021-08
MITSUBISHI

TEREX

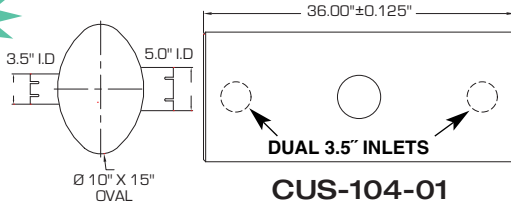

CUS-104-01
TEREX TS18 O.E# 9255471

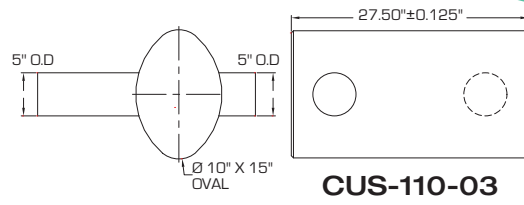

CUS-110-03
TEREX 7251

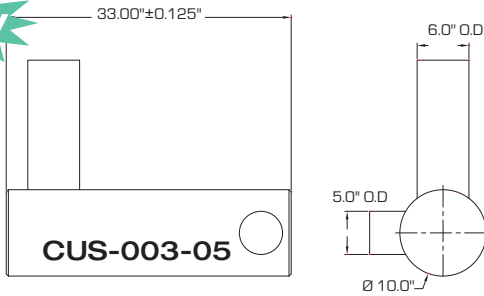

CUS-003-05

TEREX 8230B

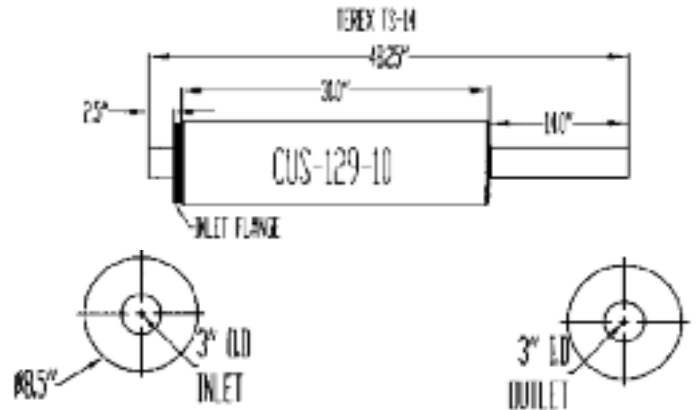

CUS-129-10

INLET FLANGE

3" I.D. INLET

3" I.D. OUTLET

VOLVO

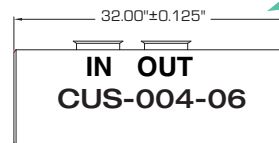
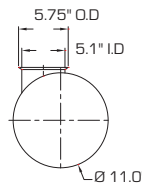

CUS-004-06
VOLVO O.E# 203569

UNITED MUFFLER CORP.

U.S. toll free 1-800-247-5391 • Fax 515-224-0727 • website: www.auto-jet.com
Canada toll free 1-866-229-3402 • Fax 519-455-1103 • website: www.unitedmuffler.com

OR 15

OFF-ROAD EQUIPMENT

EXHAUST GAS PURIFIERS

 **FACT:** Propane engines, although they seem very clean, are the second worst carbon monoxide (CO) emitters.

Average CO emissions from a well-maintained internal combustion engine:

- Diesel Engine 1,000 - 1,500 PPM
- Propane Engine 3,000 - 10,000 PPM
- Gasoline Engine 20,000 - 80,000 PPM

Industrial equipment (forklift trucks, sweepers, and construction machinery), operating in confined, poorly ventilated areas, affect the health of their operators and other employees. Headaches or nausea often attributed to stress on the job, are often symptoms of carbon monoxide poisoning.

Air quality standards in a work place are specified by the Occupational Safety and Health Administration (OSHA) and other governmental bodies. These agencies specify that the threshold limit value (TLV) for CO exposure per eight (8) hour shift cannot exceed **35 parts per million (PPM)**.



 **SOLUTION:** Exhaust Gas Purifier is a genuine solution to this problem.

- Over 90% reduction of toxic gases (immediately after engine start-up)
- Extra catalytic surface for the best possible efficiency
- Corrosion resistant materials used to build the units
- Wide variety of direct replacement designs (reduces installation time to the minimum)
- Low back pressure (no loss of power)
- Maintenance free
- 1-year workmanship and performance warranty
- Pyrometer kit included, propane only
- The most affordable product of this kind on the market: immediate availability and technical support

 **ACTION:** Take advantage of our professional expertise.
CALL NOW FOR MORE INFORMATION!

UNITED MUFFLER CORP.

U.S. toll free 1-800-247-5391 • Fax 515-224-0727 • website: www.auto-jet.com
Canada toll free 1-866-229-3402 • Fax 519-455-1103 • website: www.unitedmuffler.com

OR 16

OFF-ROAD EQUIPMENT

EXHAUST GAS PURIFIERS

WE HAVE A FULL LINE OF DIRECT FIT EXHAUST PURIFIERS AVAILABLE FOR:

ADVANCE	JCB	SIMON
BOBCAT	JOHN DEERE	SNORKEL LIFT
BOSS	KALMAR	TAKUECHI
CASE	KOHLER	TAMROCK
CATERPILLAR	KOMATSU	TARGET
CLARK	KUBOTA	TENNANT
DAEWOO	MANITOU	THOMAS
GEHL	MITSUBISHI	TOYOTA
GENIE	MUSTANG	WAGNER
GROVE	NEW HOLLAND	WHITE
HANIX	NISSAN	YALE
HYSTER	SCAT	YANMAR

- Pyrometer kits included with all propane units
- NETT™ products come with a one-year workmanship and performance warranty

THE FOLLOWING INFORMATION IS REQUIRED TO QUOTE A PRICE:

1. Make and model of your machine
2. Cubic inch displacement of engine
3. Turbo or naturally aspirated
4. Type of fuel used
5. RPM of machine when it is operated

This information is usually located in the shop manual.

Call today for a quote!

UNITED MUFFLER CORP.

U.S. toll free 1-800-247-5391 • Fax 515-224-0727 • website: www.auto-jet.com
Canada toll free 1-866-229-3402 • Fax 519-455-1103 • website: www.unitedmuffler.com

OR 17